

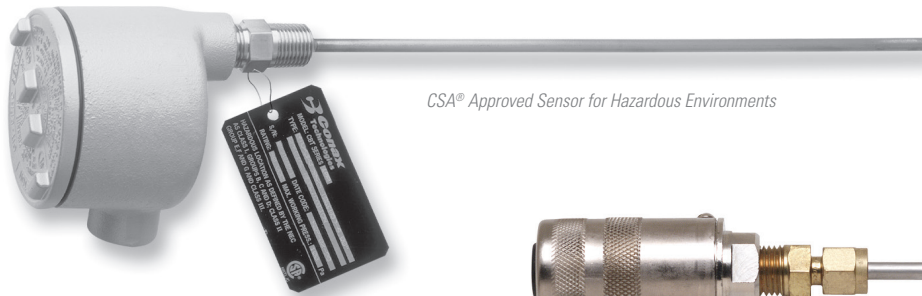

Thermocouple and RTD Assemblies

The Complete Guide to Temperature Sensors



CSA® Approved Sensor for Hazardous Environments



Sensor with a Conax B-Series Termination Head and Conax Compression Seal Fitting

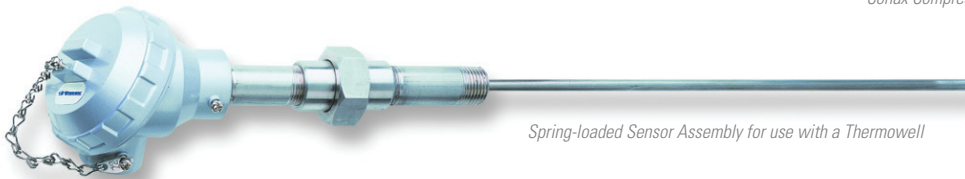

Spring-loaded Sensor Assembly for use with a Thermowell



Multi-point Sensors with a Conax Compression Seal Fitting and Plug and Jack Terminations

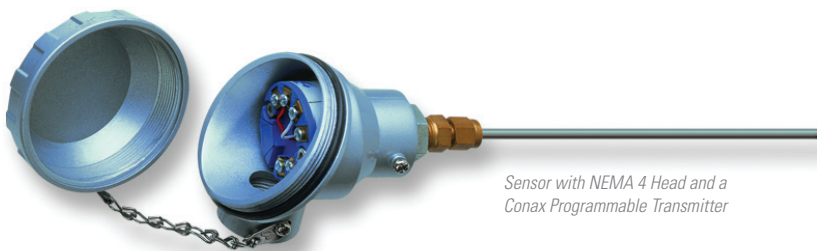

Sensor with NEMA 4 Head and a Conax Programmable Transmitter



Spring-loaded Sensor with a Flanged Thermowell



Sensor with Weldpad and an Exclusive Conax Terminal Barrel with Leadwire

The Quality and Performance Leader



The Quality and Performance Leader

Conax Technologies has designed and manufactured over one million temperature sensors and almost as many compression seals in our state-of-the-art production facility. Our sales and engineering staff continues to break new ground with innovative custom designs that enhance performance of OEM and non-OEM products.

We offer an extensive selection of sensor calibrations, sheath materials, termination types and mounting styles to create the ideal assembly for your requirements. Our high temperature sensors can tolerate a remarkable upper service temperature of 4,500°F (2,482°C).

From simple off-the-shelf assemblies to the most complicated design challenges, turn to Conax Technologies for quality, innovation and on-time delivery.

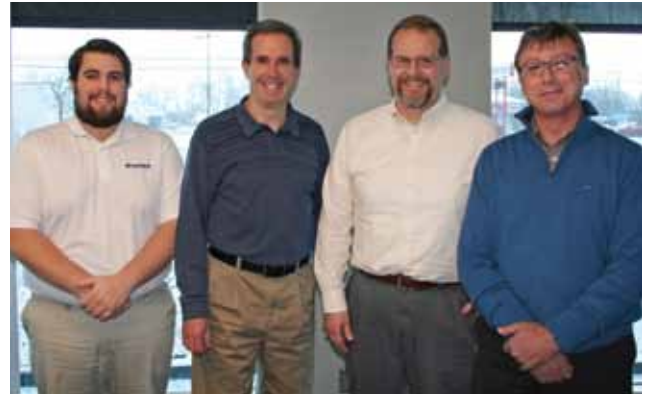

Experience, Knowledge and Creativity

During the past 60 years, Conax Technologies has developed a reputation as the company to turn to for innovative solutions to temperature sensing challenges. Our knowledgeable, multi-disciplinary sales and engineering staff welcomes the opportunity to discuss challenging applications and then present our solutions.

We have product specialists in key industrial markets – power generation, semiconductor, oil and gas, aerospace, chemical and pharmaceutical. Visit our website to learn more about our expertise.



Global Presence

We provide professional technical consultation through our extensive global sales organization. We have sales engineers throughout the world ready to help you when you need it. No technical challenge is too great for us.

If your main business is in one country and your production facilities are in others, our global network can coordinate all aspects of your worldwide supply chain requirements – ordering, shipping, installation and service.

Our customer list includes companies of all sizes from the largest Fortune 500 companies to the smallest engineering firms. We know how to get the job done no matter how large or small the application.



Our Headquarters

Our fully integrated, modern US facility features some of the most sophisticated manufacturing systems available. Complete in-house capabilities include computer-aided engineering, design and manufacturing. We have state-of-the-art equipment for machining, assembly, welding, calibrating and testing all parameters of performance. All Conax Technologies products are produced under stringent quality assurance programs.

Ask about our Compression Seals – The Finest in the World

Our compression seals can withstand pressure in excess of 30,000 psig (2,070 bar). Our unique 'soft sealant' technology when combined with mechanical compression results in a remarkably secure seal on probes, tubes, cables and conductors that must pass through a pressure or environmental boundary.

We have over 20 compression seal feedthrough and fitting product families. One of them will be right for your application.

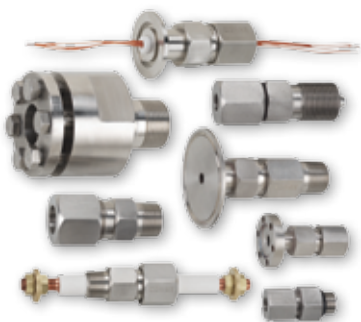

Table of Contents

	Page
Engineering, Testing and Calibration Services	4-5
RTD Assemblies	
RTD Assemblies – Components and Descriptions	6-7
RTD Assemblies with Terminal Head and Direct Mounting	8-9
RTD Assemblies with Terminal Head and Adjustable Mounting Fitting	10-11
RTD Assemblies with Terminal Head and Spring-Loaded Mounting	12-13
RTD Assemblies with Leadwire (T3/T4) Termination and Terminal Barrel	14-15
RTD Assemblies with PJFC-Plug/Jack Termination	16-17
RTD Assemblies with B-Series Terminal Head	18-19
Thermocouple Assemblies	
Thermocouple Assemblies – Components and Descriptions	20-23
Thermocouple Assemblies with Terminal Head and Direct Mounting	24-25
Thermocouple Assemblies with Terminal Head and Adjustable Mounting Fitting	26-27
Thermocouple Assemblies with Terminal Head and Spring-Loaded Mounting	28-29
Thermocouple Assemblies with Leadwire (T3/T4) Termination and Terminal Barrel	30-31
Thermocouple Assemblies with PJFC-Plug/Jack Termination	32-33
Thermocouple Assemblies with B-Series Terminal Head	34-35
Standard Mounting Methods	36-37
Additional Mounting Methods	38-39
Spring Loaded Assemblies	40-41
Replacement Probes	41
Product Identification Methods	41
Termination Styles	42-47
Signal Conditioning – Transmitters	48-53
Thermowells and Pipewells	
Introduction to Thermowells	54-55
Threaded Thermowells	56-57
Weld-In Thermowells	58
Socket-Weld Thermowells	59
ANSI Flanged Thermowells	60-61
Sanitary Flange Thermowells	62
Limited Space Thermowells	63
Van Stone Thermowells	63
Pipewells	64-65
Engineered Solutions –Semiconductor	66-67
Engineered Solutions – Power Generation	68-69
Miniature Bearing Sensors	70-73
Special Applications	74-80
Technical Data	81-95

Specifications are subject to change without notice. Material substitutions may be made without notice, subject to availability. Dimensions, ranges, tolerances and standards outside the specifications noted in this catalog may be available. Consult the factory. All designs and trademarks not otherwise noted are the property of Conax Technologies LLC. All rights reserved.

Conax Technologies built its reputation on exceptional engineering capabilities and dedication to a thorough understanding of all aspects of temperature measurement. That tradition continues today, with a full complement of engineering, test, quality assurance and calibration services available in our state-of-the-art manufacturing facility.

Conax engineers welcome the opportunity to discuss and develop solutions to challenging applications. In addition, we offer the latest technology in test equipment for prototyping and design to assist in development of new solutions to customer problems.

This dedication to excellence is also a foundation of our quality assurance program. Raw materials for critical components are thoroughly tested prior to assembly, and all RTDs and thermocouples undergo rigorous electrical inspection before shipment. Conax Quality Assurance programs conform to ISO 9001/ANSI/ASQC Q9001:2008, MIL-I-45208A and MIL-I-45662 standards. Specific tests may be ordered by a customer to meet application standards.

Our in-house capabilities include:

- Temperature Sensor Calibration
- Time Response Testing in accordance with ASTM E644 methods and procedures
- X-Ray and Liquid Dye Penetrant Non-Destructive Testing
- Thermowell Analysis to ASME Performance Test Code 19.3
- Vibration Testing
- Hydrostatic & Pneumatic Pressure Testing
- Helium Mass Spectrometer Leak Testing
- Temperature/Humidity Chambers
- Dimensional & Optical Gauging Systems

Calibration Services

While all Conax sensors are designed to perform accurately, calibration can often be useful in ensuring that your system will provide the most accurate output possible at a given temperature point. Calibration services report the actual deviation of a specific sensor at a given temperature within the allowable limits of error. This improves the overall system accuracy by providing the data to subtract out the sensor error. As sensor characteristics change over time due to aging, mechanical working and effects of environment, periodic recalibration is essential to re-establish the known deviation and ensure that your sensor system continues to provide accurate data.

Conax Technologies can precision calibrate your thermocouples, RTDs and thermistors, alone or in assemblies, using industry accepted comparison techniques in a modern, environmentally controlled calibration lab to the following specifications:

- Calibration to NIST traceable standards
- Calibration methods and procedures complying with ASTM E220 and E644
- Calibration ranges:
 - -30° F to +3000° F (-34° C to +1650° C) (For lower temperatures, consult factory)
 - -320° F (-195.8° C) (Boiling Point of Liquid Nitrogen)
 - For 900° F or higher, the minimum probe length is 18 inches.
- Temperature control methods include highly stable liquid baths, fluidized powder baths or electrically heated tube furnaces.

Reports

Detailed calibration reports are provided for each test temperature, indicating the temperature of the unit under test, the temperature of the calibration standard, and the allowable deviation vs. the actual deviation.

For RTDs, a resistance vs. temperature report based on the Callendar Van Dusen equation can be provided. This report specifies the temperature vs. resistance characteristics specific to the RTD under test when the sensor is calibrated at a minimum of three points.

Each report is certified by highly trained quality personnel and is maintained on file for future reference.

Calibration Guidelines

Sheath Material	Maximum Recommended* Calibration Temperature
Stainless Steel	1650° F (899° C)
Inconel	2100° F (1149° C)
Noble Metal (Platinum)	3000° F (1650° C)
Ceramic (Alumina)	3000° F (1650° C)
Refractory Metal (Molybdenum)	800° F (427° C) in air 3000° F (1650° C) in inert atmospheres

**Recommended temperatures are a guide and can be exceeded pending Thermocouple and RTD element type.*

Calibration Capabilities

As a company committed to the pursuit of excellence, Conax Technologies has developed a fully automated calibration system utilizing the following components:

- Nanovoltmeter specifically designed for low voltage measurements
- Nanovolt scanning system featuring provisions to reduce thermal EMF effects
- Source meter used to source current and voltage for RTD and transmitter calibrations
- Custom calibration software

This cutting edge system controls the furnace settings, determines when stability is achieved (by calculating the standard deviations of the readings from each of the devices), and collects and saves data at each temperature for each thermocouple junction or RTD element as well as the NIST traceable standard. Calibrations are conducted using comparison techniques in accordance with the requirements of ASTM E220 as well as our quality system, certified to ISO 9001:2008. We have been able to meet the ongoing and unique needs of our customers' calibration and reporting requirements with regular system updates and enhancements because we have maintained the in-house capability to regularly upgrade this system.

The Conax Technologies Calibration Lab houses a wide array of both heated and refrigerated baths and furnaces to meet our customers' varied application requirements. Using NIST traceable standards we can perform temperature sensor calibrations ranging from -184°F to 3002°F (-120°C to 1650°C), as well as calibrations at -320°F (-195.8°C), the boiling point of liquid nitrogen.

Our standard Conax Certificate of Calibration includes order information, details the equipment used for the testing and lists the standard temperature, the specimen EMF, the specimen temperature and the temperature deviation of each nominal temperature in the calibration. Additionally, the deviation is compared to the selected acceptance limit and compliance to the standard is verified.

Contact Conax Technologies today to discuss your temperature sensor calibration requirements. We will be happy to discuss how we can put our state-of-the-art calibration system to work for you!

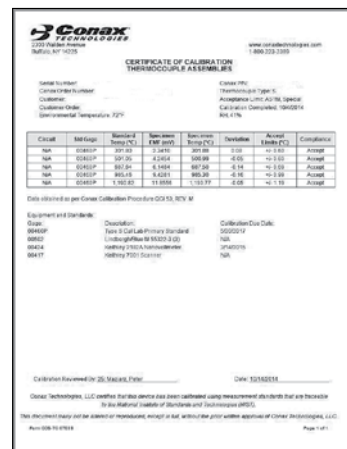
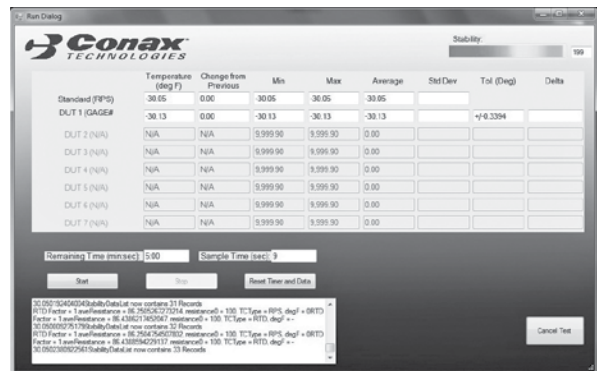
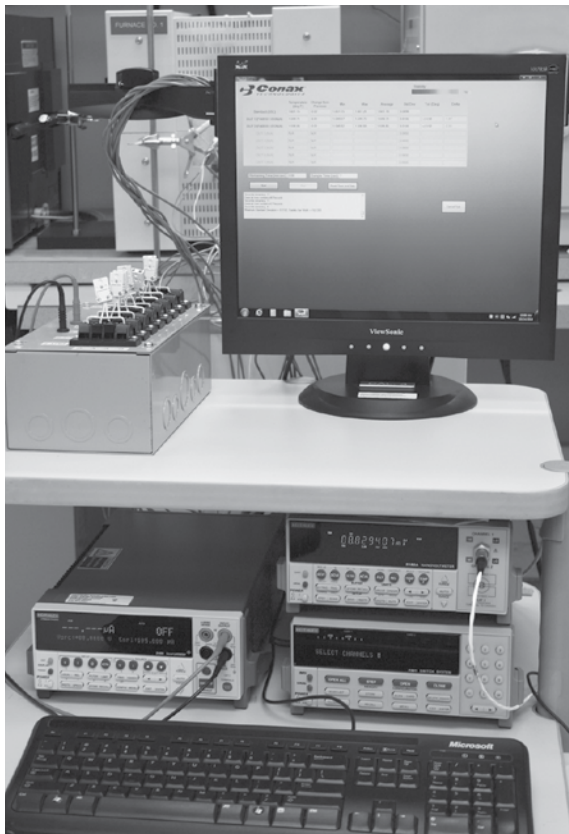

Conax **wirewound platinum RTD assemblies** feature a wirewound element encased in either a stainless steel or Inconel 600 sheath. The RTD's nickel leadwires are supported and insulated throughout the sheath with densely compacted high-purity magnesium oxide. This allows the sensor to be bent like a thermocouple except in the tip portion that contains the element.

M-style construction uses a powder-filled tubewell construction with bare leadwire strung through pre-formed MgO insulators and attached directly to the element. This assembly is inserted into a closed-end tubewell, which is then filled with Alumina Oxide (Al_2O_3) powder and capped with potting compound. **E-style construction** features a similar tubewell construction, with Teflon[®]-insulated leadwires brazed to the element. The tubewell is then filled with Alumina Oxide (Al_2O_3) powder and capped with potting compound. In both cases, the minimum active length is 3" and the assemblies should not be bent.

RTD assemblies can be provided with a wide variety of termination styles and mounting fittings to meet the needs of your application. Conax also offers numerous sensor tolerances, sheath diameters and sheath materials. This section outlines the key choices needed to specify the correct Conax part description for your needs.

In each case, you will be asked to select the:

- sensor element to meet your operating conditions and specifications
- sensor tolerance
- lead configuration corresponding to the number of leads your application requires
- sheath material and size
- termination style
- optional mounting configuration
- sheath length

🔗 **For Assistance**

Wirewound Platinum Element Assembly

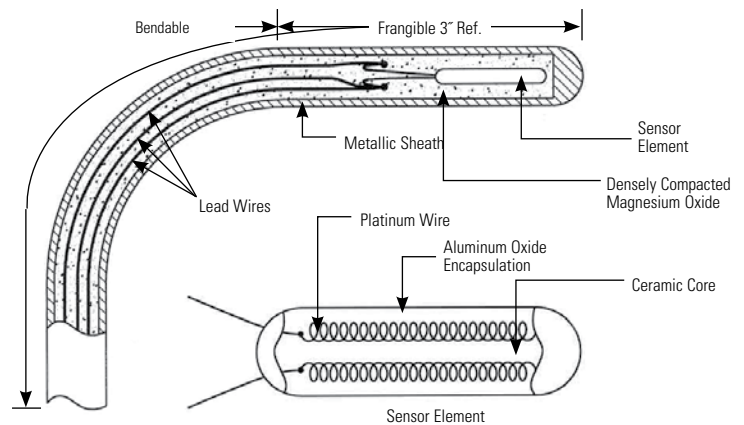

Sensor Element Descriptions

Catalog Code	Description	Operating Range	
ERTD41	Wirewound Copper, 10Ω (9.05Ω actual) @ 0° C, 0.00426 Ω/Ω/°C	-70° C to +150° C	-94° F to +300° F
ERTD42	Wirewound Nickel, 120Ω @ 0° C, 0.00672 Ω/Ω/°C	-40° C to +180° C	-40° F to +350° F
RTD43	Wirewound Platinum, 100Ω @ 0° C, 0.00385 Ω/Ω/°C	-200° C to +600° C	-328° F to +1112° F
MRTDF43	Thin Film Platinum, 100Ω @ 0° C, 0.00385 Ω/Ω/°C	-50° C to +550° C	-58° F to +1022° F
RTD44	Wirewound Platinum, 100Ω @ 0° C, 0.00385 Ω/Ω/°C	-200° C to +800° C	-328° F to +1472° F
ARTD44	Wirewound Platinum, 100Ω @ 0° C, 0.00385 Ω/Ω/°C	-196° C to +600° C	-321° F to +1112° F
RTD45	Wirewound Platinum, 100Ω @ 0° C, 0.003916 Ω/Ω/°C	-200° C to +600° C	-328° F to +1112° F
RTD86	Wirewound Platinum, 200Ω @ 0° C, 0.00385 Ω/Ω/°C	-200° C to +600° C	-328° F to +1112° F
MRTDF430	Thin Film Platinum, 1000Ω @ 0° C, 0.00385 Ω/Ω/°C	-50° C to +550° C	-58° F to +1022° F

Note: Operating temperatures apply to element only. Assembly operating temperature depends on materials and construction.

When the RTD must fit into an existing network, the ice point resistance and temperature coefficient should match that of the readout equipment – usually found on the equipment nameplate.

Wirewound platinum elements consist of a filament encapsulated within longitudinal holes in a ceramic body. Thin-film elements (designated by "F") consist of a platinum film deposited onto a ceramic substrate and are available only in powder-filled construction.

ASTM E1137 specifications are met by ARTD44.

These sensor types are also available: RTD48, Wirewound Platinum, 10Ω @ 0° C, 0.00385 Ω/Ω/°C; MRTDF215, Thin Film Platinum, 500Ω @ 0° C, 0.00385 Ω/Ω/°C. Consult factory.

Wirewound platinum element assemblies are also available in E-style and M-style construction, W tolerance, for certain applications. Consult factory.

Sensor Tolerances

Class (Catalog Code)	Tolerance at 0°C (°C)										
	ERTD41		ERTD42		MRTDF43	RTD43 & RTD44		RTD45		RTD86	MRTDF430
	Single	Single	Dual	Single	Single	Dual	Single	Dual	Single	Single	
Class B (W)*	-	-	-	±0.3	±0.3	±0.3	±0.3	±0.3	±0.3	±0.3	±0.3
1/3 Class B (V)	-	-	-	-	±0.1	-	±0.1	-	-	-	-
X	±0.4	±0.8	±1.4	-	-	-	-	-	-	-	-
Class A (S)**	-	-	-	-	±0.15	-	±0.15	-	-	-	-

Notes: - This table represents tolerance values for 3-wire and 4-wire RTDs. Caution must be exercised with 2-wire RTDs and 3-wire RTDs with longer than standard termination leads because possible error can be introduced by leadwire resistance.
 - Class A and Class B tolerances are based on EN 60751:1996 for platinum elements.

- For ASTM E1137 assemblies, ARTD44, W tolerance applies, 4-wire lead configuration.
 * Type W tolerance sensors are the most widely used in the industry.
 ** Type S should be 4 four-wire to ensure accuracy.

Sheath Diameter and Material Availabilities

Catalog Code		Sheath OD (inches)	Wall Thickness (nominal)	Sensor Element	Single				Dual	
316 Stainless Steel	INCONEL 600				W	V	X	S	W	X
316SS12 316SS118 (3mm)	INC12	0.125	0.020	RTD43	•	•		•	•	
				MRTDF43	•					
				RTD44	•	•		•		
316SS18	INC18	0.187	0.028	RTD45	•	•		•		
				RTD43	•	•		•	•	
				MRTDF43	•					
				RTD44	•	•		•	•	
				RTD45	•	•		•	•	
316SS25 316SS236 (6mm)	INC25	0.250	0.033	ERTD41			•			
				ERTD42			•			•
				RTD43	•	•		•	•	
				MRTDF43	•					
				RTD44	•	•		•	•	
				ARTD44	•					
				RTD45	•	•		•	•	
				RTD86	•					
				MRTDF430	•					

Notes: - Per ASTM E1137, stainless steel is recommended for service temperatures not exceeding 900° F (480° C). Inconel 600 is recommended for service temperatures not exceeding 1202° F (650° C). Conax endorses these recommendations. Above 1202° F (650° C), high purity alumina sheathing is suggested.
 - All 0.125" sheath diameters can be supplied containing up to four wires.
 All 0.187 and 0.250" sheath diameters can be supplied containing up to eight wires.

- Maximum continuous standard probe length is 20 feet. For longer lengths, please consult the factory.

Active Length

The active length must be specified as the last portion of the catalog description. The active length is the distance in inches from the termination to the sensor tip, as shown in the drawing. Note that you must order the active length, not the immersion. The active length is available in 1/16" increments.

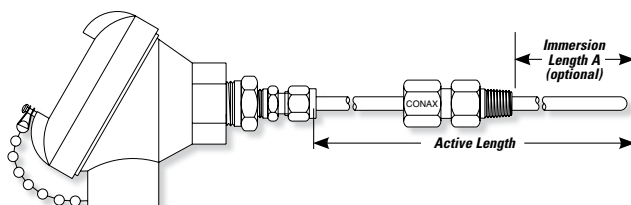

With adjustable fittings and spring-load assemblies, the immersion length is measured from the end of the fitting to the tip of the probe. In cases where this length must be called out in the catalog description, it is added at the end of the catalog number as follows:

Example: RTD-SS12-U-T5AL-SL-12.50", A=3.50"
 (A indicates the immersion length)

Conax RTD assemblies offer a wide variety of terminal head styles to meet application needs. In direct mount models, the sheath is attached to the terminal head using either a W8 fitting or a Conax manufactured “soft seal” compression fitting. Compression seal models are provided in different sizes and with various sealant materials to ensure proper function in a wide range of environments. All provided direct mount fittings serve as mounting devices and environmental seals.





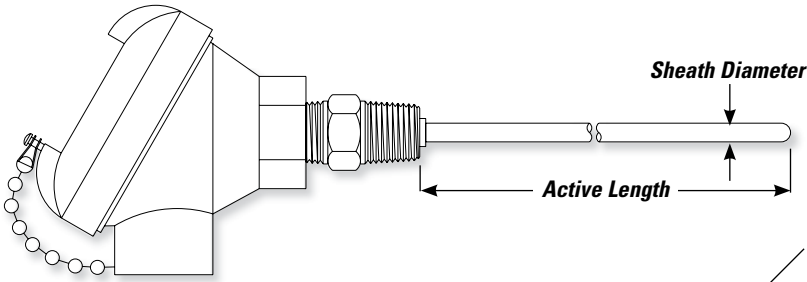



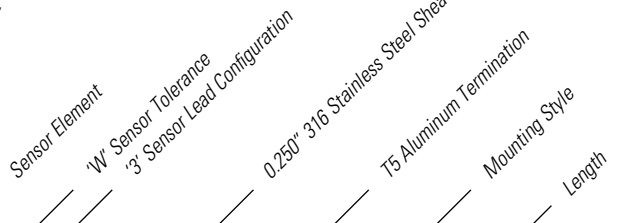

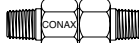

Specify Sensor Element	Specify Sensor Tolerance	Specify Sensor Lead Configuration	Specify Sheath Material & Size
<p>RTD43 Platinum</p> <ul style="list-style-type: none"> • 100Ω @ 0° C • α = 0.00385 Ω/Ω/°C • -200° C to +600° C • -328° F to +1112° F <p>MRTDF43 Platinum</p> <ul style="list-style-type: none"> • 100Ω @ 0° C • α = 0.00385 Ω/Ω/°C • -50° C to +550° C • -58° F to +1022° F <p>RTD44 Platinum</p> <ul style="list-style-type: none"> • 100Ω @ 0° C • α = 0.00385 Ω/Ω/°C • -200° C to +800° C • -328° F to +1472° F • Inconel 600 sheath standard <p>RTD45 Platinum</p> <ul style="list-style-type: none"> • 100Ω @ 0° C • α = 0.003916 Ω/Ω/°C • -200° C to +600° C • -328° F to +1112° F <p>RTD86 Platinum</p> <ul style="list-style-type: none"> • 200Ω @ 0° C • α = 0.00385 Ω/Ω/°C • -200° C to +600° C • -328° F to +1112° F <p>MRTDF430 Platinum</p> <ul style="list-style-type: none"> • 1000Ω @ 0° C • α = 0.00385 Ω/Ω/°C • -50° C to +550° C • -58° F to +1022° F • Available with 0.250" sheath diameter or larger 	<p>W (Class B)</p> <ul style="list-style-type: none"> • Available for RTD43, 44 and 45, single and dual; and RTD86, MRTDF43 and MRTDF430, single only • Tolerance at 0° C is ±0.3° C <p>V (1/3 Class B)</p> <ul style="list-style-type: none"> • Available for RTD43, 44 and 45 single only • Tolerance at 0° C is ±0.1° C <p>S (Class A)</p> <ul style="list-style-type: none"> • Available for RTD43, 44 and 45 single only • Tolerance at 0° C is ±0.15° C <p>X</p> <ul style="list-style-type: none"> • Available for ERTD41, single only; tolerance at 0° C is ±0.4° C • Available for ERTD42, single; tolerance at 0° C is ±0.8° C • Available for ERTD42, dual; tolerance at 0° C is ±1.4° C 	<p>2 2-WIRE SINGLE (RED, WHITE)</p> <p>3 3-WIRE SINGLE (RED, RED, WHITE)</p> <p>4 4-WIRE SINGLE (RED, RED, WHITE, WHITE)</p> <p>6 2-WIRE DUAL (RED, RED, WHITE, WHITE)</p> <p>7 3-WIRE DUAL (RED, RED, RED, WHITE, WHITE)</p> <p>8 4-WIRE DUAL (RED, RED, RED, RED, WHITE, WHITE, WHITE, WHITE)</p>	<p>316 Stainless Steel</p> <p>316SS118</p> <ul style="list-style-type: none"> • 3 mm <p>316SS12</p> <ul style="list-style-type: none"> • 0.125" diameter <p>316SS18</p> <ul style="list-style-type: none"> • 0.187" diameter <p>316SS236</p> <ul style="list-style-type: none"> • 6 mm <p>316SS25</p> <ul style="list-style-type: none"> • 0.250" diameter <p>Inconel 600</p> <p>INC12</p> <ul style="list-style-type: none"> • 0.125" diameter • Standard sheath material for RTD44 <p>INC18</p> <ul style="list-style-type: none"> • 0.187" diameter • Standard sheath material for RTD44 <p>INC25</p> <ul style="list-style-type: none"> • 0.250" diameter • Standard sheath material for RTD44
<p>ERTD41 Copper</p> <ul style="list-style-type: none"> • 10Ω (9.05Ω actual) @ 0° C • α = 0.00426 Ω/Ω/°C • -70° C to +150° C • -94° F to +300° F • Available with 0.250" sheath diameter or larger <p>ERTD42 Nickel</p> <ul style="list-style-type: none"> • 120Ω @ 0° C • α = 0.00672 Ω/Ω/°C • -40° C to +180° C • -40° F to +350° F • Available with 0.250" sheath diameter or larger 		<p><i>Note: 0.125" and 0.187" diameter sheaths can contain up to 4 wires; 0.250" diameter sheaths can contain up to 8 wires.</i></p>	<p><i>Note: For additional diameters and other sheath materials, see pages 7.</i></p>

Note: For ASTM E1137 assemblies, use ordering prefix ARTD44W4-SS25 or ARTD44W4-INC25.

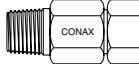

Progressive Description Example: **RTD43W3-316SS25-T5AL(W8)-12.00"**



Specify Termination Style	Specify Mounting Style	Specify Length in Inches (required)
 <p>T5AL - Aluminum T5CI - Cast Iron</p> <ul style="list-style-type: none"> NEMA 4 rated Conduit port 3/4 NPT 	 <p>T11</p> <ul style="list-style-type: none"> Weather proof Aluminum construction Conduit port 1/2 NPT 	 <p>PG2</p> <ul style="list-style-type: none"> For 0.125", 0.187" and 0.250" diameter sheath Stainless steel construction Mounting thread 1/4 NPT
 <p>T5SS</p> <ul style="list-style-type: none"> NEMA 4X rated 316 stainless steel construction Conduit port 3/4 NPT 	 <p>T11PL</p> <ul style="list-style-type: none"> Weather proof Plastic construction Conduit port 1/2 NPSM 	<p>PG2BL – Lava sealant PG2BT – Teflon sealant PG2BN – Neoprene sealant PG2BV – Viton sealant PG2BG – Grafoil sealant</p>
 <p>T7</p> <ul style="list-style-type: none"> Weather proof Aluminum conduit box accommodates up to 8 terminals Conduit port 3/4 NPT 	 <p>T12</p> <ul style="list-style-type: none"> Weather proof Aluminum construction Flip-top head Conduit port 1/2 NPT 	 <p>PG4</p> <ul style="list-style-type: none"> For 0.250" diameter sheath Stainless steel construction Mounting thread 1/2 NPT
 <p>T8E</p> <ul style="list-style-type: none"> Explosion proof rating Class I, Group B, C & D Class II, Group E, F & G Class III Gray iron body with aluminum screw cover NEMA 4 rated Conduit port 1/2 NPT 	 <p>T13</p> <ul style="list-style-type: none"> FDA compliant, NEMA 4 rated White, unpigmented polypropylene construction Conduit port 3/4 NPT 	<p>PG4BL – Lava sealant PG4BT – Teflon sealant PG4BN – Neoprene sealant PG4BV – Viton sealant PG4BG – Grafoil sealant</p>
	<p><i>Note: For additional terminal head types and detailed descriptions, see page 43-47.</i></p>	 <p>W4</p> <ul style="list-style-type: none"> For 0.125", 0.187" and 0.250" diameter sheath 316 stainless steel construction Mounting thread 1/4 NPT Sheath welded to fitting
	 <p>T13F</p> <ul style="list-style-type: none"> FDA compliant, NEMA 4X rated White, unpigmented polypropylene construction Flip-top head Conduit port 3/4 NPT 	 <p>W8</p> <ul style="list-style-type: none"> For 0.125", 0.187" and 0.250" diameter sheath 316 stainless steel construction Mounting thread 1/2 NPT Sheath welded to fitting

Note: For sealant material details, see page 37.

Conax RTD assemblies can be supplied with a wide variety of terminal head styles to meet application needs. Adjustable mounting fittings using Conax "soft seal" compression fittings allow the immersion depth of the sheath to be easily adjusted in the field and provide pressure or vacuum sealing against gases or liquids. (Compression fittings are shipped untorqued.) Compression fitting models are offered in different sizes and with various sealant materials to ensure proper function in a wide range of environments. Additional information on sealing options, as well as sealant temperature and pressure ratings, can be found in our Conax Compression Seal Feedthroughs and Fittings Catalog #5001 or at www.conaxtechnologies.com.

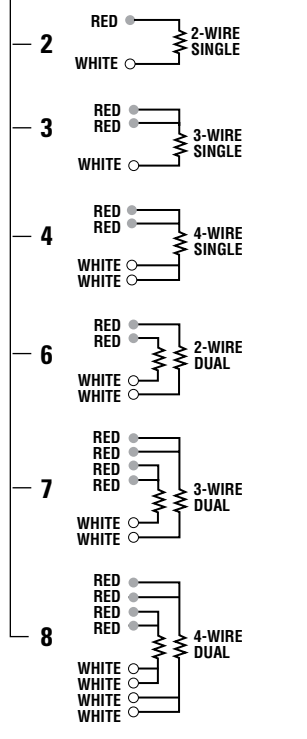
Specify Sensor Element	Specify Sensor Tolerance	Specify Sensor Lead Configuration	Specify Sheath Material & Size
<p>RTD43 Platinum</p> <ul style="list-style-type: none"> • 100Ω @ 0° C • α = 0.00385 Ω/Ω/°C • -200° C to +600° C • -328° F to +1112° F <p>MRTDF43 Platinum</p> <ul style="list-style-type: none"> • 100Ω @ 0° C • α = 0.00385 Ω/Ω/°C • -50° C to +550° C • -58° F to +1022° F <p>RTD44 Platinum</p> <ul style="list-style-type: none"> • 100Ω @ 0° C • α = 0.00385 Ω/Ω/°C • -200° C to +800° C • -328° F to +1472° F • Inconel 600 sheath standard <p>RTD45 Platinum</p> <ul style="list-style-type: none"> • 100Ω @ 0° C • α = 0.003916 Ω/Ω/°C • -200° C to +600° C • -328° F to +1112° F <p>RTD86 Platinum</p> <ul style="list-style-type: none"> • 200Ω @ 0° C • α = 0.00385 Ω/Ω/°C • -200° C to +600° C • -328° F to +1112° F <p>MRTDF430 Platinum</p> <ul style="list-style-type: none"> • 1000Ω @ 0° C • α = 0.00385 Ω/Ω/°C • -50° C to +550° C • -58° F to +1022° F • Available with 0.250" sheath diameter or larger 	<p>W (Class B)</p> <ul style="list-style-type: none"> • Available for RTD43, 44 and 45, single and dual; and RTD86, MRTDF43 and MRTDF430, single only • Tolerance at 0° C is ±0.3° C <p>V (1/3 Class B)</p> <ul style="list-style-type: none"> • Available for RTD43, 44 and 45 single only • Tolerance at 0° C is ±0.1° C <p>S (Class A)</p> <ul style="list-style-type: none"> • Available for RTD43, 44 and 45 single only • Tolerance at 0° C is ±0.15° C <p>X</p> <ul style="list-style-type: none"> • Available for ERTD41, single only; tolerance at 0° C is ±0.4° C • Available for ERTD42, single; tolerance at 0° C is ±0.8° C • Available for ERTD42, dual; tolerance at 0° C is ±1.4° C <p>ERTD41 Copper</p> <ul style="list-style-type: none"> • 10Ω (9.05Ω actual) @ 0° C • α = 0.00426 Ω/Ω/°C • -70° C to +150° C • -94° F to +300° F • Available with 0.250" sheath diameter or larger <p>ERTD42 Nickel</p> <ul style="list-style-type: none"> • 120Ω @ 0° C • α = 0.00672 Ω/Ω/°C • -40° C to +180° C • -40° F to +350° F • Available with 0.250" sheath diameter or larger 	 <p>Note: 0.125" and 0.187" diameter sheaths can contain up to 4 wires; 0.250" diameter sheaths can contain up to 8 wires.</p>	<p>316 Stainless Steel</p> <p>316SS118</p> <ul style="list-style-type: none"> • 3 mm <p>316SS12</p> <ul style="list-style-type: none"> • 0.125" diameter <p>316SS18</p> <ul style="list-style-type: none"> • 0.187" diameter <p>316SS236</p> <ul style="list-style-type: none"> • 6 mm <p>316SS25</p> <ul style="list-style-type: none"> • 0.250" diameter <p>Inconel 600</p> <p>INC12</p> <ul style="list-style-type: none"> • 0.125" diameter • Standard sheath material for RTD44 <p>INC18</p> <ul style="list-style-type: none"> • 0.187" diameter • Standard sheath material for RTD44 <p>INC25</p> <ul style="list-style-type: none"> • 0.250" diameter • Standard sheath material for RTD44 <p>Note: For additional diameters and other sheath materials, see page 7.</p>

Note: For ASTM E1137 assemblies, use ordering prefix ARTD44W4-SS25 or ARTD44W4-INC25.

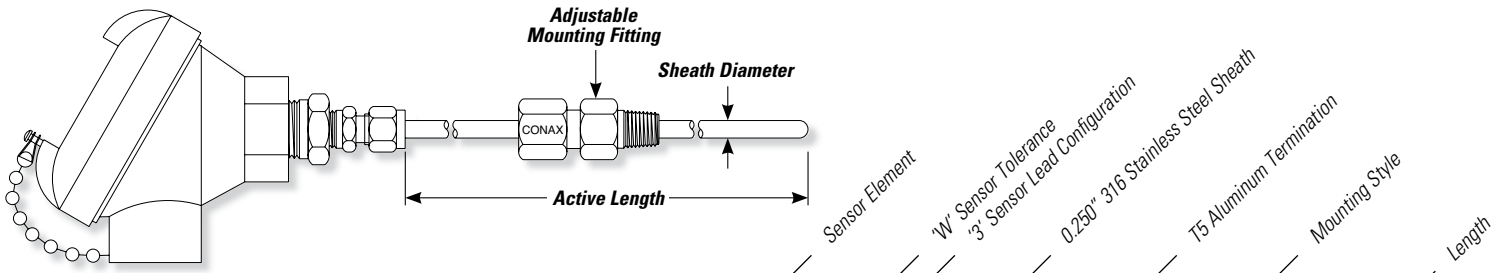

Progressive Description Example: **RTD43W3-316SS25-T5AL-PG4AL-12.00"**

Specify Termination Style		Specify Mounting Style	Specify Length in Inches (required)
<p>T5AL - Aluminum T5CI - Cast Iron</p> <ul style="list-style-type: none"> • NEMA 4 rated • Conduit port 3/4 NPT 	<p>T11</p> <ul style="list-style-type: none"> • Weather proof • Aluminum construction • Conduit port 1/2 NPT 	<p>Packing Gland</p> <p>MPG</p> <ul style="list-style-type: none"> • For 0.125" and 0.187" diameter sheath • Stainless steel construction • Mounting thread 1/8 NPT 	<p>Midlock Gland</p> <p>MK125A</p> <ul style="list-style-type: none"> • For 0.125" diameter sheath • Stainless steel construction • Stainless steel ferrule • Mounting thread 1/8 NPT
<p>T5SS</p> <ul style="list-style-type: none"> • NEMA 4X rated • 316 stainless steel construction • Conduit port 3/4 NPT 	<p>T11PL</p> <ul style="list-style-type: none"> • Weather proof • Plastic construction • Conduit port 1/2 NPSM 	<p>MPGAL – Lava sealant MPGAT – Teflon sealant MPGAN – Neoprene sealant MPGAV – Viton sealant MPGAG – Grafoil sealant</p>	<p>MK187A</p> <ul style="list-style-type: none"> • For 0.187" diameter sheath • Stainless steel construction • Stainless steel ferrule • Mounting thread 1/8 NPT
<p>T7</p> <ul style="list-style-type: none"> • Weather proof • Aluminum conduit box accommodates up to 8 terminals • Conduit port 3/4 NPT 	<p>T12</p> <ul style="list-style-type: none"> • Weather proof • Aluminum construction • Flip-top head • Conduit port 1/2 NPT 	<p>PG2</p> <ul style="list-style-type: none"> • For 0.125", 0.187" and 0.250" diameter sheath • Stainless steel construction • Mounting thread 1/4 NPT 	<p>MK250A</p> <ul style="list-style-type: none"> • For 0.250" diameter sheath • Stainless steel construction • Stainless steel ferrule • Mounting thread 1/4 NPT
<p>T8E</p> <ul style="list-style-type: none"> • Explosion proof rating Class I, Group B, C & D Class II, Group E, F & G Class III • Gray iron body with aluminum screw cover • NEMA 4 rated • Conduit port 1/2 NPT 	<p>T13T</p> <ul style="list-style-type: none"> • FDA compliant, NEMA 4X rated • White, unpigmented polypropylene construction • 4 terminal posts • Conduit port 3/4 NPT 	<p>PG2AL – Lava sealant PG2AT – Teflon sealant PG2AN – Neoprene sealant PG2AV – Viton sealant PG2AG – Grafoil sealant</p>	<p><i>Note: For sealant material details, see page 37.</i></p> <p><i>This assembly may be purchased without the mounting fitting. Omit the mounting style from the description. The catalog description in this case would be RTD43W3-316SS25-T5AL-12.00".</i></p>
	<p>T15EAL - Aluminum T15ESS - Stainless Steel</p> <p>T15EAL(ATEX)</p> <ul style="list-style-type: none"> • Explosion Proof rating Class 1, Division 1, Groups B, C and D and Dust Proof/Ignition Proof rating for Class II, Division 1, Group E, F & G • Ratings: T15EAL – NEMA 4, T15ESS – NEMA 4X • Conduit port 3/4 NPT 	<p>PG4</p> <ul style="list-style-type: none"> • For 0.250" diameter sheath • Stainless steel construction • Mounting thread 1/2 NPT 	
		<p>PG4AL – Lava sealant PG4AT – Teflon sealant PG4AN – Neoprene sealant PG4AV – Viton sealant PG4AG – Grafoil sealant</p>	

Note: For additional terminal head types and detailed descriptions, see pages 43-47.

Conax spring-loaded assemblies are used to maintain positive contact between the sensor tip and the surface to be monitored, typically used with thermowell assemblies. Conax supplies a number of styles of spring-loaded assemblies to meet application needs. Spring-loaded assemblies can be provided with all terminal heads. In addition, the T11SL model provides a spring-loaded assembly built into the T11 aluminum terminal head. This allows complete disassembly and removal of the sensor probe without dismantling the terminal head from the conduit or the vessel. For detailed information on these mounting styles, see pages 40-41.

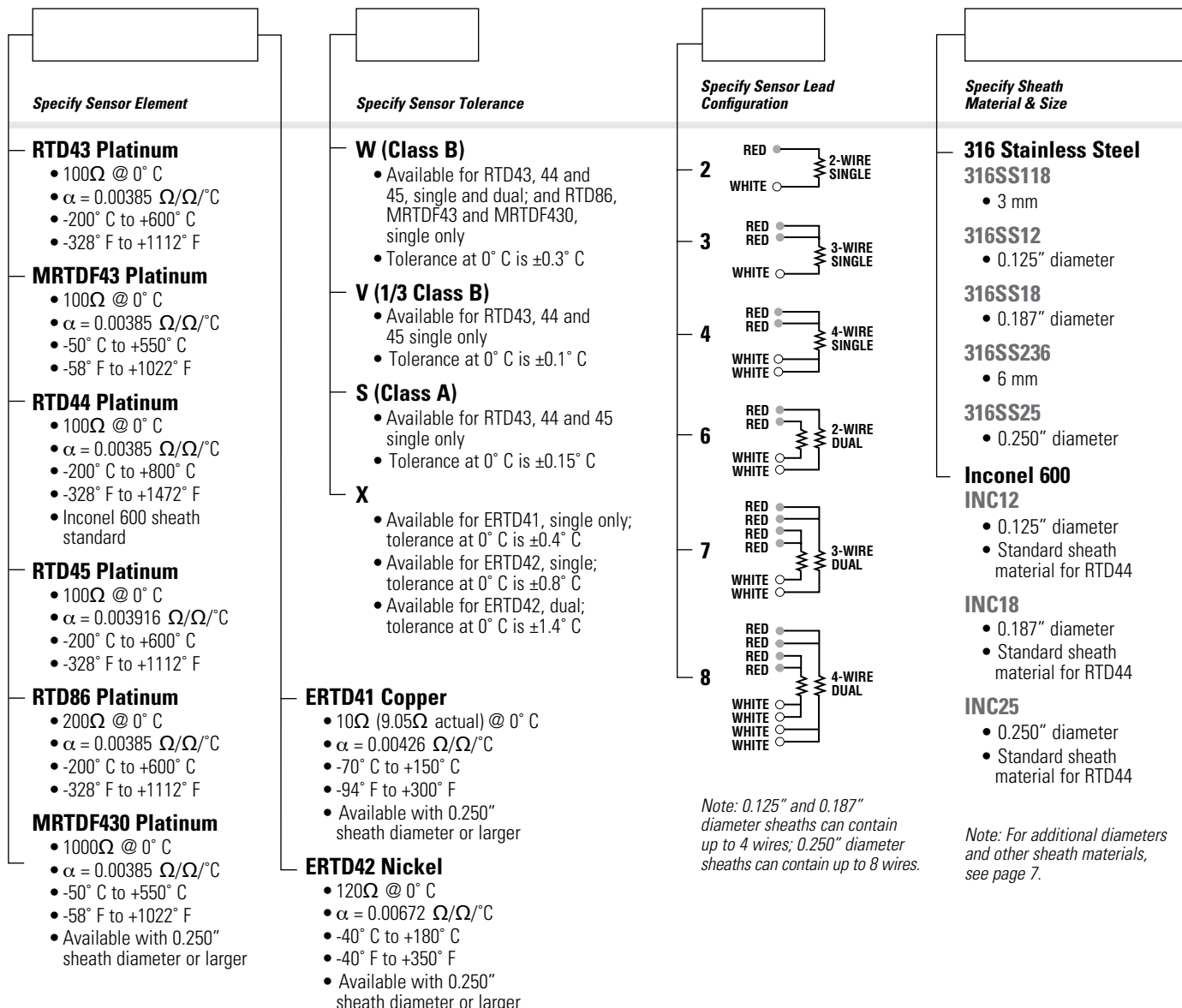

Note: For ASTM E1137 assemblies, use ordering prefix ARTD44W4-SS25 or ARTD44W4-INC25.

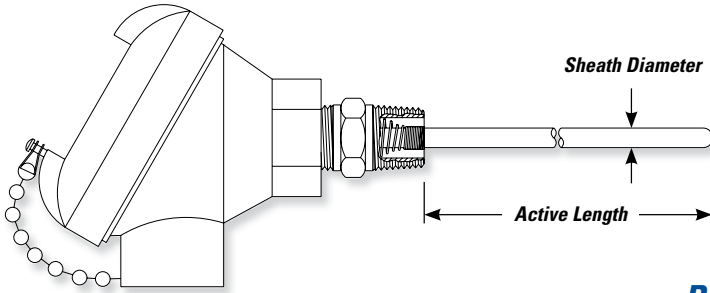

Progressive Description Example: **RTD43W3-316SS25-T5AL(CSLW)-12.00"**

Specify Termination Style



T5AL - Aluminum
T5CI - Cast Iron

- NEMA 4 rated
- Conduit port 3/4 NPT



T5SS

- NEMA 4X rated
- 316 stainless steel construction
- Conduit port 3/4 NPT



T7

- Weather proof
- Aluminum conduit box accommodates up to 8 terminals
- Conduit port 3/4 NPT



T8E

- Explosion proof rating Class I, Group B, C & D Class II, Group E, F & G Class III
- Gray iron body with aluminum screw cover
- NEMA 4 rated
- Conduit port 1/2 NPT



T11

- Weather proof
- Aluminum construction
- Conduit port 1/2 NPT



T11PL

- Weather proof
- Plastic construction
- Conduit port 1/2 NPT



T12

- Weather proof
- Aluminum construction
- Flip-top head
- Conduit port 1/2 NPT



T13T

- FDA compliant, NEMA 4X rated
- White, unpigmented polypropylene construction
- 4 terminal posts
- Conduit port 3/4 NPT

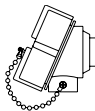

T15EAL - Aluminum
T15ESS - Stainless Steel

T15EAL(ATEX)

- Explosion Proof rating Class 1, Division 1, Groups B, C and D and Dust Proof/Ignition Proof rating for Class II, Division 1, Group E, F & G
- Ratings: T15EAL – NEMA 4, T15ESS – NEMA 4X
- Conduit port 3/4 NPT

Specify Mounting Style

CSLW

- For 0.125", 0.187" and 0.250" diameter sheaths
- Stainless steel construction
- Mounting thread 1/2 NPT

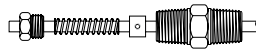

SLAN

- For 0.125", 0.187" and 0.250" diameter sheaths
- Stainless steel construction
- Mounting thread 1/2 NPT
- Probe position can be adjusted in the field

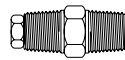

SLANS

- For 0.250" diameter sheath
- Includes Viton O-ring
- Stainless steel construction
- Mounting thread 1/2 NPT
- Probe position can be adjusted in the field

Specify Length in Inches (required)



SLN

- For 0.125", 0.187" and 0.250" diameter sheath
- Mounting thread 1/2 NPT
- Most durable

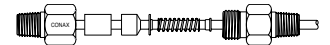

SL

- Spring-loaded packing gland
- Spring travel: 1/4" to 3/8"
- 2-8 pounds spring pressure
- Stainless steel construction, Teflon sealant
- Available with B cap for direct mount
- *Additional dimensional data required, see page 40.*

SL12

- For 0.125" diameter sheath
- Mounting thread 1/8 NPT

SL18

- For 0.187" diameter sheath
- Mounting thread 1/4 NPT

SL25

- For 0.250" diameter sheath
- Mounting thread 1/2 NPT
- Optional 1/4 NPT mounting thread is available. Consult factory.

For additional information on spring-loaded mounting styles, see pages 40-41.

Note: For additional terminal head types and detailed descriptions, see pages 43-47.

This exclusive Conax design provides a practically unbreakable connection between the leadwire and the probe lead. The T3 epoxy-filled transition is supplied with 24 AWG stranded silver-plated copper Teflon-insulated wire with Teflon overall as standard. Silicone impregnated fiberglass insulation is also available.

T4 termination provides a stainless steel overbraid for maximum flexibility and abrasion resistance. The overbraid is embedded in the epoxy-filled material to ensure mechanical strength. Standard extension leads are 24" long. Longer leads are available on request.

Specify Sensor Element	Specify Sensor Tolerance	Specify Sensor Lead Configuration	Specify Sheath Material & Size
<p>RTD43 Platinum</p> <ul style="list-style-type: none"> • 100Ω @ 0° C • α = 0.00385 Ω/Ω/°C • -200° C to +600° C • -328° F to +1112° F <p>MRTDF43 Platinum</p> <ul style="list-style-type: none"> • 100Ω @ 0° C • α = 0.00385 Ω/Ω/°C • -50° C to +550° C • -58° F to +1022° F <p>RTD44 Platinum</p> <ul style="list-style-type: none"> • 100Ω @ 0° C • α = 0.00385 Ω/Ω/°C • -200° C to +800° C • -328° F to +1472° F • Inconel 600 sheath standard <p>RTD45 Platinum</p> <ul style="list-style-type: none"> • 100Ω @ 0° C • α = 0.003916 Ω/Ω/°C • -200° C to +600° C • -328° F to +1112° F <p>RTD86 Platinum</p> <ul style="list-style-type: none"> • 200Ω @ 0° C • α = 0.00385 Ω/Ω/°C • -200° C to +600° C • -328° F to +1112° F <p>MRTDF430 Platinum</p> <ul style="list-style-type: none"> • 1000Ω @ 0° C • α = 0.00385 Ω/Ω/°C • -50° C to +550° C • -58° F to +1022° F • Available with 0.250" sheath diameter or larger 	<p>W (Class B)</p> <ul style="list-style-type: none"> • Available for RTD43, 44 and 45, single and dual; and RTD86, MRTDF43 and MRTDF430, single only • Tolerance at 0° C is ±0.3° C <p>V (1/3 Class B)</p> <ul style="list-style-type: none"> • Available for RTD43, 44 and 45 single only • Tolerance at 0° C is ±0.1° C <p>S (Class A)</p> <ul style="list-style-type: none"> • Available for RTD43, 44 and 45 single only • Tolerance at 0° C is ±0.15° C <p>X</p> <ul style="list-style-type: none"> • Available for ERTD41, single only; tolerance at 0° C is ±0.4° C • Available for ERTD42, single; tolerance at 0° C is ±0.8° C • Available for ERTD42, dual; tolerance at 0° C is ±1.4° C <p>ERTD41 Copper</p> <ul style="list-style-type: none"> • 10Ω (9.05Ω actual) @ 0° C • α = 0.00426 Ω/Ω/°C • -70° C to +150° C • -94° F to +300° F • Available with 0.250" sheath diameter or larger <p>ERTD42 Nickel</p> <ul style="list-style-type: none"> • 120Ω @ 0° C • α = 0.00672 Ω/Ω/°C • -40° C to +180° C • -40° F to +350° F • Available with 0.250" sheath diameter or larger 	<p>2 RED WHITE 2-WIRE SINGLE</p> <p>3 RED RED WHITE 3-WIRE SINGLE</p> <p>4 RED RED WHITE WHITE 4-WIRE SINGLE</p> <p>6 RED RED WHITE WHITE 2-WIRE DUAL</p> <p>7 RED RED RED WHITE 3-WIRE DUAL</p> <p>8 RED RED RED RED WHITE WHITE WHITE 4-WIRE DUAL</p>	<p>316 Stainless Steel</p> <p>316SS118</p> <ul style="list-style-type: none"> • 3 mm <p>316SS12</p> <ul style="list-style-type: none"> • 0.125" diameter <p>316SS18</p> <ul style="list-style-type: none"> • 0.187" diameter <p>316SS236</p> <ul style="list-style-type: none"> • 6 mm <p>316SS25</p> <ul style="list-style-type: none"> • 0.250" diameter <p>Inconel 600</p> <p>INC12</p> <ul style="list-style-type: none"> • 0.125" diameter • Standard sheath material for RTD44 <p>INC18</p> <ul style="list-style-type: none"> • 0.187" diameter • Standard sheath material for RTD44 <p>INC25</p> <ul style="list-style-type: none"> • 0.250" diameter • Standard sheath material for RTD44
<p>Note: For 0.125" and 0.187" diameter sheaths can contain up to 4 wires; 0.250" diameter sheaths can contain up to 8 wires.</p>			<p>Note: For additional diameters and other sheath materials, see page 7.</p>

Note: For ASTM E1137 assemblies, use ordering prefix ARTD44W4-SS25 or ARTD44W4-INC25.

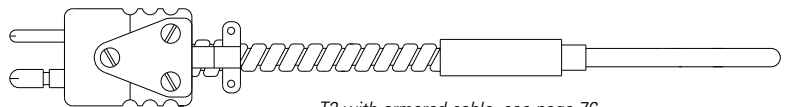

T3 with armored cable, see page 76 (Also available without armor.)

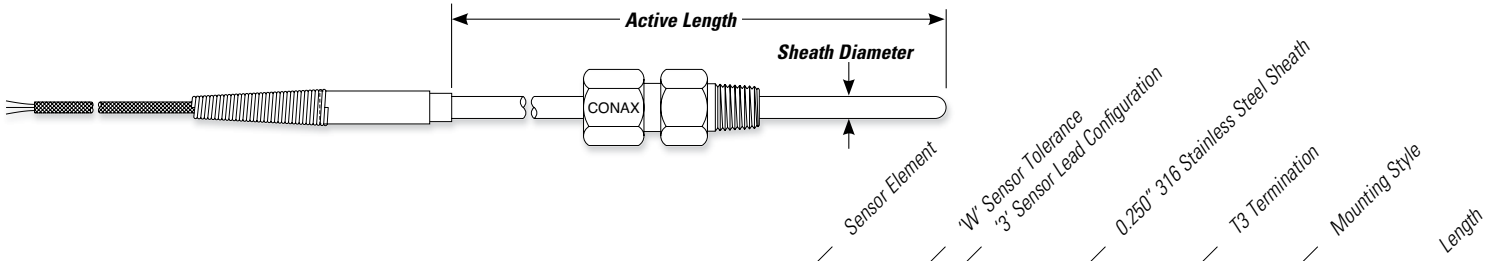

Progressive Description Example: **RTD43W3-316SS25-T3-PG4AL-12.00"**

Specify Termination Style

T3

- Teflon insulated leadwire
- Service temperature: 300° F (150° C)

T4

- Teflon insulated leadwire
- Stainless steel overbraid
- Service temperature: 300° F (150° C)

T4F

- Fiberglass/silicone impregnated leadwire insulation
- Stainless steel overbraid
- Service temperature: 300° F (150° C)

T4(HT)

- Fiberglass/silicone impregnated
- Stainless steel overbraid
- High temperature encapsulant
- Service temperature: 900° F (482° C)

For longer lead length, specify in feet, rounded up to the nearest foot. Example: T3(3 FT)

Optional leadwire insulation types are available. Example: PVC requested – T3(3 FT-PVC). Consult factory for availability.

For detailed descriptions of termination styles, see pages 42-43.

Specify Mounting Style (optional)

Packing Gland



- For 0.125" and 0.187" diameter sheath
- Stainless steel construction
- Mounting thread 1/8 NPT

- MPGAL – Lava sealant**
- MPGAT – Teflon sealant**
- MPGAN – Neoprene sealant**
- MPGAV – Viton sealant**
- MPGAG – Grafoil sealant**

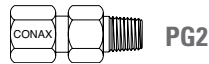

- For 0.125", 0.187" and 0.250" diameter sheath
- Stainless steel construction
- Mounting thread 1/4 NPT

- PG2AL – Lava sealant**
- PG2AT – Teflon sealant**
- PG2AN – Neoprene sealant**
- PG2AV – Viton sealant**
- PG2AG – Grafoil sealant**

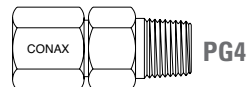

- For 0.250" diameter sheath
- Stainless steel construction
- Mounting thread 1/2 NPT

- PG4AL – Lava sealant**
- PG4AT – Teflon sealant**
- PG4AN – Neoprene sealant**
- PG4AV – Viton sealant**
- PG4AG – Grafoil sealant**

Specify Length in Inches (required)

Midlock Gland



- For 0.125" diameter sheath
- Stainless steel construction
- Stainless steel ferrule
- Mounting thread 1/8 NPT



- For 0.187" diameter sheath
- Stainless steel construction
- Stainless steel ferrule
- Mounting thread 1/8 NPT



- For 0.250" diameter sheath
- Stainless steel construction
- Stainless steel ferrule
- Mounting thread 1/4 NPT

Spring-Load



- For 0.125", 0.187" and 0.250" diameter sheaths
- Stainless steel construction
- Mounting thread 1/2 NPT





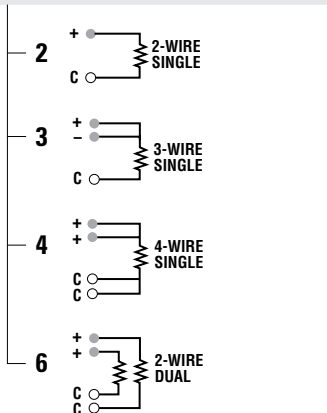

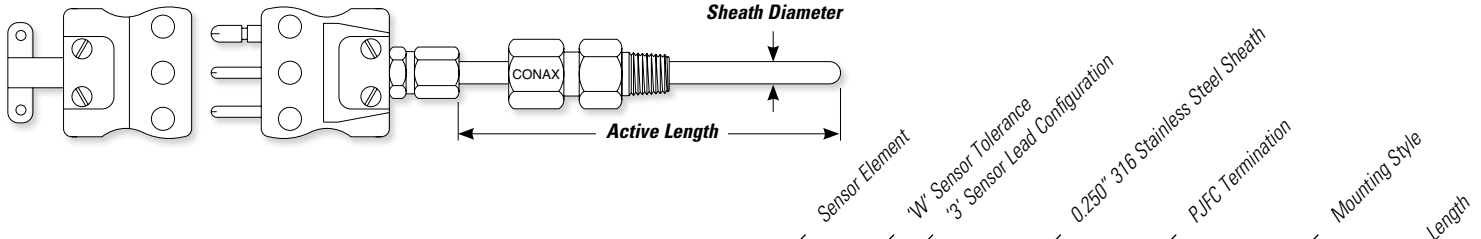

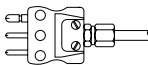
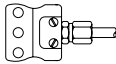
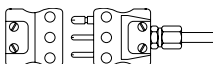
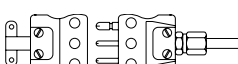

Note: For sealant material details, see page 37.

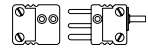
Conax polarized plug and jack assembly bodies are made from molded glass-filled thermoset compounds, with copper pin material. The connector is color-coded white. A metal ferrule tube adapter secures the probe in place, and a wire clamp is used to hold the wire. Standard assemblies are designed to operate in temperatures up to 300° F (150° C). High temperature assemblies operate up to 800° F (427° C) and are color-coded red. Polarity marks are molded in the bodies for installation assistance. Individual plugs, jacks, tube adapters and wire clamps are also available.

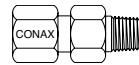
Specify Sensor Element	Specify Sensor Tolerance	Specify Sensor Lead Configuration	Specify Sheath Material & Size
<p>RTD43 Platinum</p> <ul style="list-style-type: none"> • 100Ω @ 0° C • α = 0.00385 Ω/Ω/°C • -200° C to +600° C • -328° F to +1112° F <p>MRTDF43 Platinum</p> <ul style="list-style-type: none"> • 100Ω @ 0° C • α = 0.00385 Ω/Ω/°C • -50° C to +550° C • -58° F to +1022° F <p>RTD44 Platinum</p> <ul style="list-style-type: none"> • 100Ω @ 0° C • α = 0.00385 Ω/Ω/°C • -200° C to +800° C • -328° F to +1472° F • Inconel 600 sheath standard <p>RTD45 Platinum</p> <ul style="list-style-type: none"> • 100Ω @ 0° C • α = 0.003916 Ω/Ω/°C • -200° C to +600° C • -328° F to +1112° F <p>RTD86 Platinum</p> <ul style="list-style-type: none"> • 200Ω @ 0° C • α = 0.00385 Ω/Ω/°C • -200° C to +600° C • -328° F to +1112° F <p>MRTDF430 Platinum</p> <ul style="list-style-type: none"> • 1000Ω @ 0° C • α = 0.00385 Ω/Ω/°C • -50° C to +550° C • -58° F to +1022° F • Available with 0.250" sheath diameter or larger 	<p>W (Class B)</p> <ul style="list-style-type: none"> • Available for RTD43, 44 and 45, single and dual; and RTD86, MRTDF43 and MRTDF430, single only • Tolerance at 0° C is ±0.3° C <p>V (1/3 Class B)</p> <ul style="list-style-type: none"> • Available for RTD43, 44 and 45 single only • Tolerance at 0° C is ±0.1° C <p>S (Class A)</p> <ul style="list-style-type: none"> • Available for RTD43, 44 and 45 single only • Tolerance at 0° C is ±0.15° C <p>X</p> <ul style="list-style-type: none"> • Available for ERTD41, single only; tolerance at 0° C is ±0.4° C • Available for ERTD42, single; tolerance at 0° C is ±0.8° C • Available for ERTD42, dual; tolerance at 0° C is ±1.4° C 	 <p>Note: 0.125" and 0.187" diameter sheaths can contain up to 4 wires; 0.250" diameter sheaths can contain up to 6 wires.</p>	<p>316 Stainless Steel</p> <p>316SS118</p> <ul style="list-style-type: none"> • 3 mm <p>316SS12</p> <ul style="list-style-type: none"> • 0.125" diameter <p>316SS18</p> <ul style="list-style-type: none"> • 0.187" diameter <p>316SS236</p> <ul style="list-style-type: none"> • 6 mm <p>316SS25</p> <ul style="list-style-type: none"> • 0.250" diameter <p>Inconel 600</p> <p>INC12</p> <ul style="list-style-type: none"> • 0.125" diameter • Standard sheath material for RTD44 <p>INC18</p> <ul style="list-style-type: none"> • 0.187" diameter • Standard sheath material for RTD44 <p>INC25</p> <ul style="list-style-type: none"> • 0.250" diameter • Standard sheath material for RTD44
<p>Note: For ASTM E1137 assemblies, use ordering prefix ARTD44W4-SS25 or ARTD44W4-INC25.</p>	<p>ERTD41 Copper</p> <ul style="list-style-type: none"> • 10Ω (9.05Ω actual) @ 0° C • α = 0.00426 Ω/Ω/°C • -70° C to +150° C • -94° F to +300° F • Available with 0.250" sheath diameter or larger <p>ERTD42 Nickel</p> <ul style="list-style-type: none"> • 120Ω @ 0° C • α = 0.00672 Ω/Ω/°C • -40° C to +180° C • -40° F to +350° F • Available with 0.250" sheath diameter or larger 		<p>Note: For additional diameters and other sheath materials, see page 7.</p>

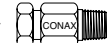

Progressive Description Example: **RTD43W3-316SS25-PJFC-PG4AL-12.00"**

Specify Termination Style		Specify Mounting Style (optional)	Specify Length in Inches (required)
 <p>PJ – Male plug only PJHT – Male plug only, high temperature</p>  <p>PF – Female jack only PFHT – Female jack only, high temperature</p>  <p>PJF – Male plug & female jack PJFHT – Male plug & female jack, high temperature</p>  <p>PJFC – Plug, jack & wire clamp PJFCHT – Plug, jack & wire clamp, high temperature</p>	 <p>MPJ – Miniature male plug only MPJHT – Miniature male plug only, high temperature</p>  <p>MPF – Miniature female jack only MPFHT – Miniature female jack only, high temperature</p>  <p>MPJF – Miniature male plug and female jack MPJFHT – Miniature male plug and female jack, high temperature</p>  <p>MPJFC – Miniature plug, jack and wire clamp MPJFCHT – Miniature plug, jack and wire clamp, high temperature</p>	<p>Packing Gland</p>  <p>MPG</p> <ul style="list-style-type: none"> • For 0.125" and 0.187" diameter sheath • Stainless steel construction • Mounting thread 1/8 NPT <p>MPGAL – Lava sealant MPGAT – Teflon sealant MPGAN – Neoprene sealant MPGAV – Viton sealant MPGAG – Grafoil sealant</p>  <p>PG2</p> <ul style="list-style-type: none"> • For 0.125", 0.187" and 0.250" diameter sheath • Stainless steel construction • Mounting thread 1/4 NPT <p>PG2AL – Lava sealant PG2AT – Teflon sealant PG2AN – Neoprene sealant PG2AV – Viton sealant PG2AG – Grafoil sealant</p>  <p>PG4</p> <ul style="list-style-type: none"> • For 0.250" diameter sheath • Stainless steel construction • Mounting thread 1/2 NPT <p>PG4AL – Lava sealant PG4AT – Teflon sealant PG4AN – Neoprene sealant PG4AV – Viton sealant PG4AG – Grafoil sealant</p>	<p>Midlock Gland</p>  <p>MK125A</p> <ul style="list-style-type: none"> • For 0.125" diameter sheath • Stainless steel construction • Stainless steel ferrule • Mounting thread 1/8 NPT  <p>MK187A</p> <ul style="list-style-type: none"> • For 0.187" diameter sheath • Stainless steel construction • Stainless steel ferrule • Mounting thread 1/8 NPT  <p>MK250A</p> <ul style="list-style-type: none"> • For 0.250" diameter sheath • Stainless steel construction • Stainless steel ferrule • Mounting thread 1/4 NPT <p>Spring-Load</p>  <p>CSLP</p> <ul style="list-style-type: none"> • For 0.125", 0.187" and 0.250" diameter sheaths • Stainless steel construction • Mounting thread 1/2 NPT

Note: For sealant material details, see page 37.

For detailed descriptions of termination styles, see page 46.

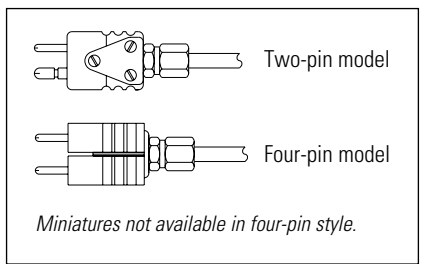

Conax B-Series heads are compact, lightweight terminal heads that provide convenient hook-up of customer extension wire. The cap and body are nickel-plated to resist corrosion. The ceramic terminal block contains zinc-plated brass terminal posts that accept up to 14 AWG wire. Bayonet-style cover allows easy access to the terminal posts. B-Series heads are provided in direct or adjustable mounting styles.

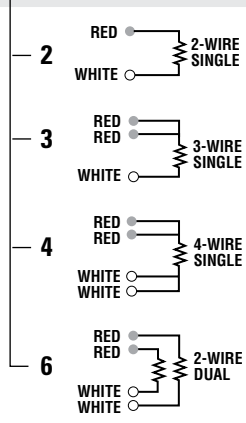
<p>Specify Sensor Element</p> <p>RTD43 Platinum</p> <ul style="list-style-type: none"> • 100Ω @ 0° C • α = 0.00385 Ω/Ω/°C • -200° C to +600° C • -328° F to +1112° F <p>MRTDF43 Platinum</p> <ul style="list-style-type: none"> • 100Ω @ 0° C • α = 0.00385 Ω/Ω/°C • -50° C to +550° C • -58° F to +1022° F <p>RTD44 Platinum</p> <ul style="list-style-type: none"> • 100Ω @ 0° C • α = 0.00385 Ω/Ω/°C • -200° C to +800° C • -328° F to +1472° F • Inconel 600 sheath standard <p>RTD45 Platinum</p> <ul style="list-style-type: none"> • 100Ω @ 0° C • α = 0.003916 Ω/Ω/°C • -200° C to +600° C • -328° F to +1112° F <p>RTD86 Platinum</p> <ul style="list-style-type: none"> • 200Ω @ 0° C • α = 0.00385 Ω/Ω/°C • -200° C to +600° C • -328° F to +1112° F <p>MRTDF430 Platinum</p> <ul style="list-style-type: none"> • 1000Ω @ 0° C • α = 0.00385 Ω/Ω/°C • -50° C to +550° C • -58° F to +1022° F • Available with 0.250" sheath diameter or larger 	<p>Specify Sensor Tolerance</p> <p>W (Class B)</p> <ul style="list-style-type: none"> • Available for RTD43, 44 and 45, single and dual; and RTD86, MRTDF43 and MRTDF430, single only • Tolerance at 0° C is ±0.3° C <p>V (1/3 Class B)</p> <ul style="list-style-type: none"> • Available for RTD43, 44 and 45 single only • Tolerance at 0° C is ±0.1° C <p>S (Class A)</p> <ul style="list-style-type: none"> • Available for RTD43, 44 and 45 single only • Tolerance at 0° C is ±0.15° C <p>X</p> <ul style="list-style-type: none"> • Available for ERTD41, single only; tolerance at 0° C is ±0.4° C • Available for ERTD42, single; tolerance at 0° C is ±0.8° C • Available for ERTD42, dual; tolerance at 0° C is ±1.4° C <p>ERTD41 Copper</p> <ul style="list-style-type: none"> • 10Ω (9.05Ω actual) @ 0° C • α = 0.00426 Ω/Ω/°C • -70° C to +150° C • -94° F to +300° F • Available with 0.250" sheath diameter or larger <p>ERTD42 Nickel</p> <ul style="list-style-type: none"> • 120Ω @ 0° C • α = 0.00672 Ω/Ω/°C • -40° C to +180° C • -40° F to +350° F • Available with 0.250" sheath diameter or larger 	<p>Specify Sensor Lead Configuration</p> 	<p>Specify Sheath Material & Size</p> <p>316 Stainless Steel</p> <p>316SS118</p> <ul style="list-style-type: none"> • 3 mm <p>316SS12</p> <ul style="list-style-type: none"> • 0.125" diameter <p>316SS18</p> <ul style="list-style-type: none"> • 0.187" diameter <p>316SS236</p> <ul style="list-style-type: none"> • 6 mm <p>316SS25</p> <ul style="list-style-type: none"> • 0.250" diameter <p>Inconel 600</p> <p>INC12</p> <ul style="list-style-type: none"> • 0.125" diameter • Standard sheath material for RTD44 <p>INC18</p> <ul style="list-style-type: none"> • 0.187" diameter • Standard sheath material for RTD44 <p>INC25</p> <ul style="list-style-type: none"> • 0.250" diameter • Standard sheath material for RTD44
---	---	---	--

Note: For additional diameters and other sheath materials, see page 7.

Note: For ASTM E1137 assemblies, use ordering prefix ARTD44W4-SS25 or ARTD44W4-INC25.

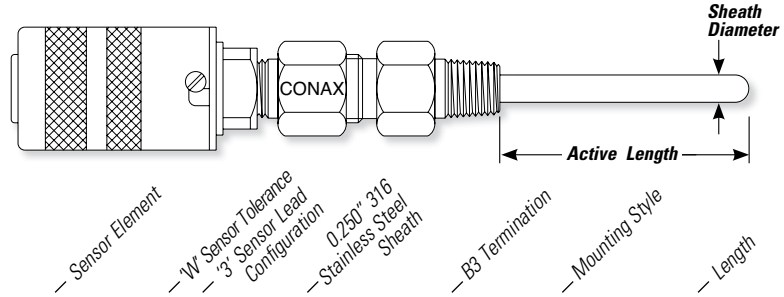

Direct Mount
Progressive Description Example: RTD43W3-316SS25-B 3(PG2BN)-12.00"

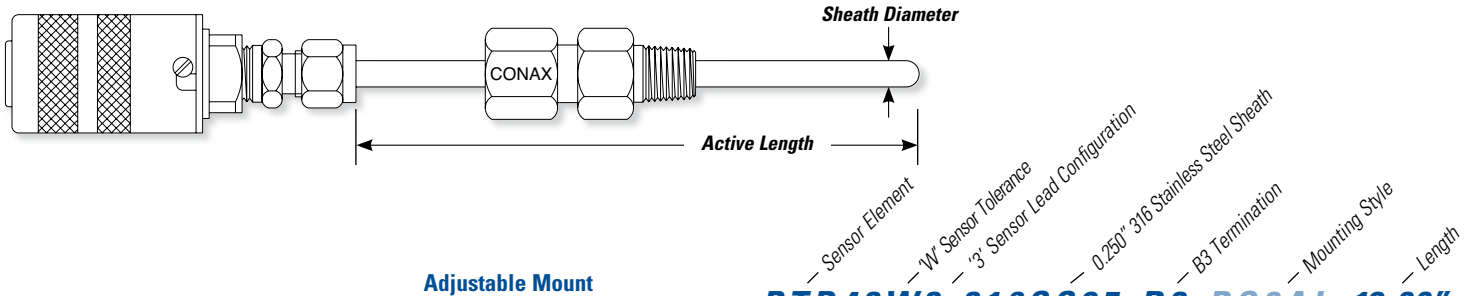

Adjustable Mount

Progressive Description Example: **RTD43W3-316SS25-B3-PG2AL-12.00"**

Specify Termination Style



B2

- Standard 2-wire
- Maximum service temperature is 200° F (93.3° C) with grommet and O-ring; 750° F (400° C) with grommet and O-ring removed.

B3

- Standard 3-wire
- Maximum service temperature is 200° F (93.3° C) with grommet and O-ring; 750° F (400° C) with grommet and O-ring removed

B4

- Standard 4-wire
- Maximum service temperature is 200° F (93.3° C) with grommet and O-ring; 750° F (400° C) with grommet and O-ring removed

For detailed descriptions of termination styles, see pages 46.

Specify Mounting Style

DIRECT MOUNT Packing Gland



MPG

- For 0.125" and 0.187" diameter sheath
- Stainless steel construction
- Mounting thread 1/8 NPT

- MPGBL** – Lava sealant
- MPGBT** – Teflon sealant
- MPGBN** – Neoprene sealant
- MPGBV** – Viton sealant
- MPGBG** – Grafoil sealant

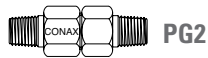

PG2

- For 0.125", 0.187" and 0.250" diameter sheath
- Stainless steel construction
- Mounting thread 1/4 NPT

- PG2BL** – Lava sealant
- PG2BT** – Teflon sealant
- PG2BN** – Neoprene sealant
- PG2BV** – Viton sealant
- PG2BG** – Grafoil sealant

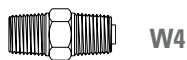

W4

- For 0.125", 0.187" & 0.250" diameter sheath
- 316 stainless steel construction
- Mounting thread 1/4 NPT
- Sheath welded to fitting

ADJUSTABLE MOUNT (optional) Packing Gland



MPG

- For 0.125" and 0.187" diameter sheath
- Stainless steel construction
- Mounting thread 1/8 NPT

- MPGAL** – Lava sealant
- MPGAT** – Teflon sealant
- MPGAN** – Neoprene sealant
- MPGAV** – Viton sealant
- MPGAG** – Grafoil sealant

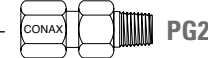

PG2

- For 0.125", 0.187" and 0.250" diameter sheath
- Stainless steel construction
- Mounting thread 1/4 NPT

- PG2AL** – Lava sealant
- PG2AT** – Teflon sealant
- PG2AN** – Neoprene sealant
- PG2AV** – Viton sealant
- PG2AG** – Grafoil sealant

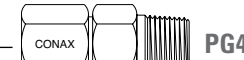

PG4

- For 0.250" diameter sheath
- Stainless steel construction
- Mounting thread 1/2 NPT

- PG4AL** – Lava sealant
- PG4AT** – Teflon sealant
- PG4AN** – Neoprene sealant
- PG4AV** – Viton sealant
- PG4AG** – Grafoil sealant

Specify Length in Inches (required)

Midlock Gland



MK125A

- For 0.125" diameter sheath
- Stainless steel construction
- Stainless steel ferrule
- Mounting thread 1/8 NPT



MK187A

- For 0.187" diameter sheath
- Stainless steel construction
- Stainless steel ferrule
- Mounting thread 1/8 NPT



MK250A

- For 0.250" diameter sheath
- Stainless steel construction
- Stainless steel ferrule
- Mounting thread 1/4 NPT

Note: For sealant material details, see page 37.

Conax thermocouple assemblies represent the culmination of 60 years experience in the design and manufacture of temperature sensors. Conax thermocouple designs have proven their durability and reliability in applications ranging from large industrial processing plants to highly specialized laboratory testing and validation. Our extensive knowledge of the science of temperature measurement and the physical properties of materials used for sheathing and insulation enables our sales engineers to recommend the most effective solutions to your application needs.

Conax thermocouple assemblies offer a wide variety of termination styles and mounting fittings, as well as extensive choices in sensor calibration, sheath diameter and sheath material. This section outlines the key choices needed to specify the correct Conax part description for your needs. In each case, you will be asked to select the:

- sensor calibration
- sheath material and size
- tip configuration
- termination style
- optional mounting configuration
- sheath length

 **For Assistance.**

Thermocouple Types

Choose the thermocouple type from the temperature range table below. Minimum requirements for all Conax thermocouples are standard limits of error, denoted by a single letter (eg. J). Special limits of error are also available above 32° F (0° C) and are designated by a double calibration letter (eg. JJ).

ANSI/ASME Designation	Calibration	Service Temperatures (Bare/Exposed Wire*)	Remarks
J	Iron vs. Constantan	32° F to 1400° F (0° C to 760° C)	For use in reducing atmospheres. Iron may oxidize if unprotected in oxidizing atmospheres. Limited use possible in oxidizing atmospheres at high temperatures; not recommended at low temperatures.
K	Chromel® vs. Alumel®	-328° F to 2300° F (-200° C to 1260° C)	For use in oxidizing atmospheres. Not recommended for reducing atmospheres.
E	Chromel vs. Constantan	-328° F to 1600° F (-200° C to 870° C)	Good for use in oxidizing atmospheres. Highest EMF output of the common thermocouples.
T	Copper vs. Constantan	-328° F to 700° F (-200° C to 370° C)	For use in oxidizing, reducing and inert atmospheres. Capable of cryogenic temperature service. Good where moisture is present.
N	Nicrosil vs. Nisil	32° F to 2300° F (0° C to 1260° C)	Less affected by the order/disorder transformation that causes calibration shifts in Type K. For use in oxidizing atmospheres.
S	Platinum-10% Rhodium vs. Platinum	32° F to 2700° F (0° C to 1480° C)	For use in oxidizing atmospheres. Alumina protection tubes are recommended to resist contamination at elevated temperatures.
R	Platinum-13% Rhodium vs. Platinum	32° F to 2700° F (0° C to 1480° C)	For use in oxidizing atmospheres. Alumina protection tubes are recommended to resist contamination at elevated temperatures.
B	Platinum-30% Rhodium vs. Platinum-6% Rhodium	1600° F to 3100° F (870° C to 1700° C)	For use in oxidizing, inert or vacuum atmospheres. Alumina protection tubes are recommended to resist contamination at elevated temperatures.
C	Tungsten-5% Rhenium vs. Tungsten-26% Rhenium	32° F to 4200° F (0° C to 2315° C)	For use in hydrogen, inert or vacuum atmospheres.

- Supplied environment data for bare or exposed wire, less protective sheath.

- For more technical and ordering information on Type S, R, B & C assemblies, request Conax High Temperature Thermocouple Bulletin 6008.

- Type C not available in special limits of error.

Sheath Materials and Sizes

Catalog Code	Sheath Diameter	Sheath Wall Thickness	Wire Gauge	Sheath Material	Upper Service Temperature	Melting Point	Remarks
SS4	0.040	0.004 to 0.005	34-35	304 SST (standard stocked probe sheath material available in all sizes)	1650° F (900° C)	2600° F (1430° C)	Standard, most economical sheath material. Resists oxidation to 1650° F (900° C).
SS6	0.062	0.006 to 0.008	30-31				
SS12	0.125	0.012 to 0.015	24-25				
SS18	0.187	0.019 to 0.023	20-21				
SS25	0.250	0.025 to 0.030	18-19				
SS37	0.375	0.037 to 0.045	14-15				
310SS		Consult Factory		310 SST	2000° F (1090° C)	2600° F (1430° C)	Excellent resistance to oxidizing and carburizing atmospheres.
316SS4	0.040	0.004 to 0.005	34-35	316 SST (stocked probe sheath material available in all sizes)	1650° F (900° C)	2600° F (1430° C)	Good weldability. Resistant to carbide precipitation.
316SS6	0.062	0.006 to 0.008	30-31				
316SS12	0.125	0.012 to 0.015	24-25				
316SS18	0.187	0.019 to 0.023	20-21				
316SS25	0.250	0.025 to 0.030	18-19				
316SS37	0.375	0.037 to 0.045	14-15				
321SS		Consult Factory		321 SST	1650° F (900° C)	2570° F (1410° C)	Excellent resistance to intergranular corrosion. Immune to organic chemical attack.
INC4	0.040	0.004 to 0.005	34-35	INCONEL 600 (standard stocked probe sheath material available in all sizes)	2100° F (1150° C)	2525° F (1390° C)	Excellent resistance to stress corrosion cracking. Used in chemical and aircraft industries.
INC6	0.062	0.006 to 0.008	30-31				
INC12	0.125	0.012 to 0.015	24-25				
INC18	0.187	0.019 to 0.023	20-21				
INC25	0.250	0.025 to 0.030	18-19				
INC37	0.375	0.037 to 0.045	14-15				
188HN		Consult Factory		HAYNES 188	2100° F (1150° C)	2400° F (1315° C)	Excellent high temperature strength and oxidation resistance to 2100° F (1150° C).
214HN		Consult Factory		HAYNES 214	2200° F (1200° C)	2475° F (1360° C)	Excellent oxidation, carbonization and chlorination resistance.
230HN		Consult Factory		HAYNES 230	2100° F (1150° C)	2440° F (1340° C)	Excellent high temperature strength and oxidation resistance to 2100° F (1150° C). Excellent resistance to nitriding environments.
HC		Consult Factory		HASTELLOY C	2000° F (1090° C)	2380° F (1300° C)	Excellent corrosion resistance to 2000° F (1090° C). Good chlorine resistance.
HX		Consult Factory		HASTELLOY X	2200° F (1200° C)	2380° F (1300° C)	Good strength to 2200° F (1200° C). Used as sheath material in aircraft industries.
Ti12	0.125	0.017 to 0.023	22-24	TITANIUM	2000° F (1090° C)	3035° F (1670° C)	Resistant to acid and chemical attack. Primary uses in aircraft applications.
TA6	0.062	0.008 to 0.012	29-30	TANTALUM	4500° F (2480° C)	5425° F (3000° C)	Resistant to acids and liquid metals, except for fuming sulphuric and hydrochloric. Subject to hydrogen and nitrogen embrittlement. Limited to 500° F (260° C) in air or oxidizing atmospheres.
TA12	0.125	0.017 to 0.023	22-24				
TA18	0.187	0.025 to 0.031	19-20				
TA25	0.250	0.035 to 0.041	17-18				
PLT4	0.040	0.004 to 0.005	34-35	PLATINUM-10% RHODIUM	3200° F (1760° C)	3360° F (1850° C)	Stronger than pure platinum. Excellent in oxidizing atmospheres.
PLT6	0.062	0.006 to 0.008	30-31				
PLT12	0.125	0.012 to 0.015	24-25				

Note: Information provided is for 2-wire material only. For 4-wire and 6-wire material, consult factory.

High-Temperature Tubewell Materials and Sizes

Catalog Type	Sheath Diameter	Sheath Material	Upper Service Temperature	Melting Point	Remarks
SA SiC	0.375 0.625 0.750	ALPHA-SINTERED SILICON CARBIDE	3000° F (1650° C)	—	No free silicon, higher density than SiC, low porosity, excellent thermal shock resistance, high chemical, corrosion and abrasion resistance. Excellent thermal conductivity. Not recommended for molten steel.
AL ₂ O ₃	0.125 0.187 0.250 0.375	ALUMINA	3450° F (1900° C)	3686° F (2030° C)	High-purity aluminum oxide offers high thermal conductivity, high electrical resistivity and good resistance to thermal shock. It also offers excellent resistance to chemical attack. Aluminum oxide functions well in oxidizing, reducing or high vacuum applications, but is not recommended for high vacuum environments in the presence of graphite at temperatures exceeding 2372° F (1300° C).
QUARTZ	CONSULT FACTORY	FUSED QUARTZ	3050° F (1677° C)	—	Excellent thermal shock resistance, non-reactive to most acids and metals, performs well in oxidizing, inert or neutral atmospheres.
MO	0.125 0.187 0.250	MOLYBDENUM	3400° F (1870° C)	4730° F (2610° C)	Molybdenum offers excellent mechanical properties at elevated temperatures and is exceptional for use in reducing or neutral atmospheres. Molybdenum offers superb thermal shock resistance and has potentially unlimited life at high temperatures in a vacuum. Pure hydrogen, argon and helium atmospheres are completely inert to molybdenum. Performance is poor in oxidizing atmospheres. Above 800° F (427° C), molybdenum will react with oxygen.

For additional technical and ordering information, request Conax High Temperature Thermocouple Bulletin 6008 Series.

Application Atmospheres

Catalog Type	Oxidizing	Reducing	Inert	Vacuum
J	G	VG	VG	VG
K	VG	NR	VG	VG
E	VG	G	VG	G
T	VG	G	VG	VG
N	VG	VG	VG	VG
S	VG	NR	G	G
R	VG	NR	G	G
B	VG	NR	VG	VG
C	NR	VG	VG	VG

G – Good

VG – Very good

NR – Not recommended

F – Fair

Sheath Type	Oxidizing	Reducing	Inert	Vacuum
304SST	VG	G	VG	VG
310SST	VG	G	VG	VG
316SST	VG	G	VG	VG
321SST	VG	G	VG	VG
INCONEL 600	VG	G	VG	VG
HAYNES 188	VG	G	VG	VG
HAYNES 214	VG	G	VG	VG
HAYNES 230	VG	G	VG	VG
HASTELLOY C	VG	VG	VG	F
HASTELLOY X	VG	G	VG	F
TITANIUM	G to 800° F	NR	G	G
TANTALUM	G to 500° F	NR	VG	VG
PLATINUM-10% RHODIUM	VG	NR	VG	G
ALPHA-SINTERED SILICON CARBIDE	VG	VG	VG	VG
ALUMINA	VG	VG	VG	VG
FUSED QUARTZ	VG	VG	VG	VG
MOLYBDENUM	G to 800° F	VG	VG	VG

Standard Tip Configurations

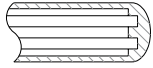

G – Grounded

- Most commonly used, not recommended for high temperature or highly corrosive environments.
- Not available for S, R, B or C thermocouples with base metal sheathing (stainless steel or Inconel).
- Measuring junction welded to sheath tip.
- Faster response and slightly lower cost than ungrounded.

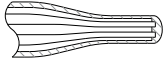

GR – Grounded, Reduced

- Same specifications as grounded, but the sheath outer diameter is reduced to obtain faster response time without loss of structural strength. The tip configuration provides for larger termination conductors, resulting in less corrosion and breakage. The length of the reduced sheath is approximately one inch.
- Not recommended for S, R, B or C thermocouples with stainless steel or Inconel sheathing.
- 0.040" OD sheath reduced to 0.032" OD (not available for Type T configuration).
- 0.062" OD sheath reduced to 0.040" OD
- 0.125" OD sheath reduced to 0.093" OD
- 0.187" OD sheath reduced to 0.125" OD
- 0.250" OD sheath reduced to 0.187" OD

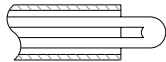

B – Bare Wire

- For the fastest response time, the thermocouple hot junction extends beyond the insulation and sheath for direct contact with the process.
- Welded, bare wire hot junction provides minimum mass.
- Exposed mineral insulation is encapsulated with alumina ceramic cement and is not completely moisture sealed. Therefore, pre-heat to 250° F (121° C) prior to operational use.

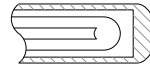

U – Ungrounded

- Provides longer life under maximum vibration, shock and corrosive conditions. Recommended for electrical applications where stray RFI/EMI could affect output. Additional insulation resistance tests can be easily made to verify thermocouple electrical integrity.
- Mineral insulation is densely compacted to eliminate voids.
- Completely homogenous welded closure at tip provides maximum corrosion resistance.
- Note on multiple elements: for dual elements with diameters 0.187" through 0.375" and triple elements with 0.250" diameter, the probes are isolated ungrounded. For all other diameters, probes are common ungrounded.

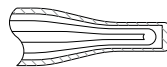

UR – Ungrounded, Reduced

- Same specifications as ungrounded, but the sheath outer diameter is reduced to obtain faster response time without loss of structural strength. The tip configuration provides for larger termination conductors, resulting in less corrosion, breakage and high sheath-to-wire and wire-to-wire insulation resistance. The length of the reduced sheath is approximately one inch.
- 0.062" OD sheath reduced to 0.040" OD
- 0.125" OD sheath reduced to 0.093" OD
- 0.187" OD sheath reduced to 0.125" OD
- 0.250" OD sheath reduced to 0.187" OD

Multiple Element Junctions:

Dual element assemblies (4-wire) require the prefix number "2"; for example: J-SS12-2U-T5. Triple element assemblies (6-wire) require the prefix number "3"; for example: J-SS12-3U-T5.

Specialty Tip Configurations

In addition to our standard tip configurations, the following are available for special applications:

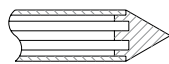

PG - Pointed, Grounded

PU - Pointed, Ungrounded

- Designed for easy insertion
- Machined with a 60° included angle
- Ideal for taking fast, repetitive readings in penetrable materials

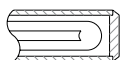

FRU - Fast Response, Ungrounded

- Uses a sterling silver tip for contact and surface temperature measurements where optimum response time and rugged construction characteristics are required.



EP- Exposed, Protected

- Designed for applications demanding fast response.
- The element is exposed within its cavity, and media flow reaches it through drilled orifices.
- Insulation is completely sealed with epoxy resin against liquid or gas penetration.
- Maximum service temperature: 300° F (150° C).

5005B THERMOCOUPLE ASSEMBLIES ■ TERMINAL HEAD AND DIRECT MOUNTING

Conax thermocouple assemblies offer a wide variety of terminal head styles to meet application needs. In direct mount models, the sheath is attached to the terminal head using either a W8 fitting or a Conax manufactured “soft seal” compression fitting. Compression seal models are provided in different sizes and with various sealant materials to ensure proper function in a wide range of environments. All provided direct mount fittings serve as mounting devices and environmental seals.

Specify Sensor Element	Specify Sheath Material	Specify Sheath Diameter	Specify Tip Configuration
<p>J – Iron/Constantan</p> <ul style="list-style-type: none"> • 32° F to +1400° F • 0° C to +760° C <p>K – Chromel/Alumel</p> <ul style="list-style-type: none"> • -328° F to +2300° F • -200° C to +1260° C <p>E – Chromel/Constantan</p> <ul style="list-style-type: none"> • -328° F to +1600° F • -200° C to +870° C <p>T – Copper/Constantan</p> <ul style="list-style-type: none"> • -328° F to +700° F • -200° C to +370° C <p>N – Nicrosil/Nisil</p> <ul style="list-style-type: none"> • 32° F to +2300° F • 0° C to +1260° C <p>S – Platinum-10% Rhodium/Platinum</p> <ul style="list-style-type: none"> • 32° F to +2700° F • 0° C to +1480° C <p>R – Platinum-13% Rhodium/Platinum</p> <ul style="list-style-type: none"> • 32° F to +2700° F • 0° C to +1480° C <p>B – Platinum-30% Rhodium/Platinum-6% Rhodium</p> <ul style="list-style-type: none"> • 1600° F to +3100° F • 870° C to +1700° C <p>C – Tungsten-5% Rhenium/Tungsten-26% Rhenium</p> <ul style="list-style-type: none"> • 32° F to +4200° F • 0° C to +2315° C 	<p>SS – 304 Stainless Steel</p> <ul style="list-style-type: none"> • Maximum service temperature: +1650° F (900° C) <p>316SS – 316 Stainless Steel</p> <ul style="list-style-type: none"> • Maximum service temperature: +1650° F (900° C) <p>INC – Inconel 600</p> <ul style="list-style-type: none"> • Maximum service temperature: +2100° F (1150° C) <p>Alternate Material</p> <p>310SS – 310 Stainless Steel</p> <p>188HN – Haynes 188</p> <p>214HN – Haynes 214</p> <p>230HN – Haynes 230</p> <p>HC – Hastelloy C</p> <p>HX – Hastelloy X</p> <p>TI – Titanium</p> <p>TA – Tantalum</p> <p>PLT – Platinum</p>	<p>12 = 0.125" diameter</p> <p>18 = 0.187" diameter</p> <p>25 = 0.250" diameter</p> <p>37 = 0.375" diameter</p> <p><i>Sheath diameters < 0.125" are available for direct mount application, review with factory.</i></p>	<p>G – Grounded</p> <p>G – Single, Grounded 2G – Dual, Grounded 3G – Triple, Grounded</p> <p>GR – Grounded, Reduced</p> <p>U – Ungrounded</p> <p>U – Single, Ungrounded 2U – Dual, Ungrounded 3U – Triple, Ungrounded</p> <p>UR – Ungrounded, Reduced</p> <p>B – Bare Wire</p>

Special limits of error are designated by a double catalog letter, e.g. JJ.





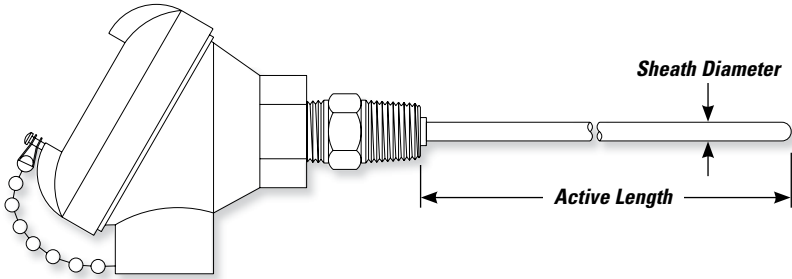







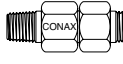

Note: For more information on tip configurations, see page 23.

TERMINAL HEAD AND DIRECT MOUNTING ■ THERMOCOUPLES



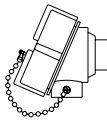



Progressive Description Example: **J-SS12-U-T5AL(W8)-12.00"**

Sensor Element
0.125" Stainless Steel Sheath
Ungrounded Tip Configuration
T5 Aluminum Termination
Mounting Style
Length

Specify Termination Style	Specify Mounting Style	Specify Length in Inches (required)
 <p>T5AL - Aluminum T5CI - Cast Iron</p> <ul style="list-style-type: none"> NEMA 4 rated Conduit port 3/4 NPT 	 <p>T11</p> <ul style="list-style-type: none"> Weather proof Aluminum construction Conduit port 1/2 NPT 	 <p>PG2</p> <ul style="list-style-type: none"> For 0.125", 0.187" and 0.250" diameter sheath Stainless steel construction Mounting thread 1/4 NPT
 <p>T5SS</p> <ul style="list-style-type: none"> NEMA 4X rated 316 stainless steel construction Conduit port 3/4 NPT 	 <p>T11PL</p> <ul style="list-style-type: none"> Weather proof Plastic construction Conduit port 1/2 NPSM 	<p>PG2BL – Lava sealant PG2BT – Teflon sealant PG2BN – Neoprene sealant PG2BV – Viton sealant PG2BG – Grafoil sealant</p>
 <p>T7</p> <ul style="list-style-type: none"> Weather proof Aluminum conduit box accommodates up to 8 terminals Conduit port 3/4 NPT 	 <p>T12</p> <ul style="list-style-type: none"> Weather proof Aluminum construction Flip-top head Conduit port 1/2 NPT 	 <p>PG4</p> <ul style="list-style-type: none"> For 0.250" and 0.375" diameter sheath Stainless steel construction Mounting thread 1/2 NPT
 <p>T8E</p> <ul style="list-style-type: none"> Explosion proof rating Class I, Group B, C & D Class II, Group E, F & G Class III Gray iron body with aluminum screw cover NEMA 4 rated Conduit port 1/2 NPT 	 <p>T13</p> <ul style="list-style-type: none"> FDA compliant, NEMA 4 rated White, unpigmented polypropylene construction Conduit port 3/4 NPT 	<p>PG4BL – Lava sealant PG4BT – Teflon sealant PG4BN – Neoprene sealant PG4BV – Viton sealant PG4BG – Grafoil sealant</p>
	 <p>T15EAL - Aluminum T15ESS - Stainless Steel T15EAL(ATEX)</p> <ul style="list-style-type: none"> Explosion Proof rating Class 1, Division 1, Groups B, C and D and Dust Proof/Ignition Proof rating for Class II, Division 1, Group E, F & G Ratings: T15EAL – NEMA 4, T15ESS – NEMA 4X Conduit port 3/4 NPT 	 <p>W4</p> <ul style="list-style-type: none"> For 0.125", 0.187" and 0.250" diameter sheath 316 stainless steel construction Mounting thread 1/4 NPT Sheath welded to fitting
	<p><i>Note: For additional terminal head types and detailed descriptions, see pages 43-47.</i></p>  <p>T13F</p> <ul style="list-style-type: none"> FDA compliant, NEMA 4X rated White, unpigmented polypropylene construction Flip-top head Conduit port 3/4 NPT 	 <p>W8</p> <ul style="list-style-type: none"> For 0.125", 0.187" and 0.250" diameter sheath 316 stainless steel construction Mounting thread 1/2 NPT Sheath welded to fitting

Note: For sealant material details, see page 37.

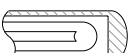
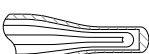
Conax thermocouple assemblies can be supplied with a wide variety of terminal head styles to meet application needs. Adjustable mounting fittings using Conax "soft seal" compression fittings allow the immersion depth of the sheath to be easily adjusted in the field and provide pressure or vacuum sealing against gases or liquids. (Compression fittings are shipped untorqued.) Compression fitting models are offered in different sizes and with various sealant materials to ensure proper function in a wide range of environments. Additional information on sealing options, as well as sealant temperature and pressure ratings, can be found in Conax Compression Seal Feedthroughs and Fittings catalog #5001 or at www.conaxtechnologies.com.

<div style="border: 1px solid black; width: 100px; height: 20px; margin-bottom: 5px;"></div> <p>Specify Sensor Element</p> <p>J – Iron/Constantan</p> <ul style="list-style-type: none"> • 32° F to +1400° F • 0° C to +760° C <p>K – Chromel/Alumel</p> <ul style="list-style-type: none"> • -328° F to +2300° F • -200° C to +1260° C <p>E – Chromel/Constantan</p> <ul style="list-style-type: none"> • -328° F to +1600° F • -200° C to +870° C <p>T – Copper/Constantan</p> <ul style="list-style-type: none"> • -328° F to +700° F • -200° C to +370° C <p>N – Nicrosil/Nisil</p> <ul style="list-style-type: none"> • 32° F to +2300° F • 0° C to +1260° C <p>S – Platinum-10% Rhodium/Platinum</p> <ul style="list-style-type: none"> • 32° F to +2700° F • 0° C to +1480° C <p>R – Platinum-13% Rhodium/Platinum</p> <ul style="list-style-type: none"> • 32° F to +2700° F • 0° C to +1480° C <p>B – Platinum-30% Rhodium/Platinum-6% Rhodium</p> <ul style="list-style-type: none"> • 1600° F to +3100° F • 870° C to +1700° C <p>C – Tungsten-5% Rhenium/Tungsten-26% Rhenium</p> <ul style="list-style-type: none"> • 32° F to +4200° F • 0° C to +2315° C 	<div style="border: 1px solid black; width: 100px; height: 20px; margin-bottom: 5px;"></div> <p>Specify Sheath Material</p> <p>SS – 304 Stainless Steel</p> <ul style="list-style-type: none"> • Maximum service temperature: +1650° F (900° C) <p>316SS – 316 Stainless Steel</p> <ul style="list-style-type: none"> • Maximum service temperature: +1650° F (900° C) <p>INC – Inconel 600</p> <ul style="list-style-type: none"> • Maximum service temperature: +2100° F (1150° C) <p>Alternate Materials</p> <p>310SS – 310 Stainless Steel</p> <p>188HN – Haynes 188</p> <p>214HN – Haynes 214</p> <p>230HN – Haynes 230</p> <p>HC – Hastelloy C</p> <p>HX – Hastelloy X</p> <p>TI – Titanium</p> <p>TA – Tantalum</p> <p>PLT – Platinum</p>	<div style="border: 1px solid black; width: 100px; height: 20px; margin-bottom: 5px;"></div> <p>Specify Sheath Diameter</p> <ul style="list-style-type: none"> – 12 = 0.125" diameter – 18 = 0.187" diameter – 25 = 0.250" diameter – 37 = 0.375" diameter 	<div style="border: 1px solid black; width: 100px; height: 20px; margin-bottom: 5px;"></div> <p>Specify Tip Configuration</p> <div style="text-align: center; margin-top: 10px;">  </div> <p>G – Grounded</p> <ul style="list-style-type: none"> G – Single, Grounded 2G – Dual, Grounded 3G – Triple, Grounded <div style="text-align: center; margin-top: 10px;">  </div> <p>GR – Grounded, Reduced</p> <div style="text-align: center; margin-top: 10px;">  </div> <p>U – Ungrounded</p> <ul style="list-style-type: none"> U – Single, Ungrounded 2U – Dual, Ungrounded 3U – Triple, Ungrounded <div style="text-align: center; margin-top: 10px;">  </div> <p>UR – Ungrounded, Reduced</p> <div style="text-align: center; margin-top: 10px;">  </div> <p>B – Bare Wire</p>
---	---	---	---

Certain calibrations and wire configurations (dual and triple) may not be available in all sheath materials and diameters. Consult factory for details.

Note: For more information on tip configurations, see page 23.

Special limits of error are designated by a double catalog letter, e.g. JJ.

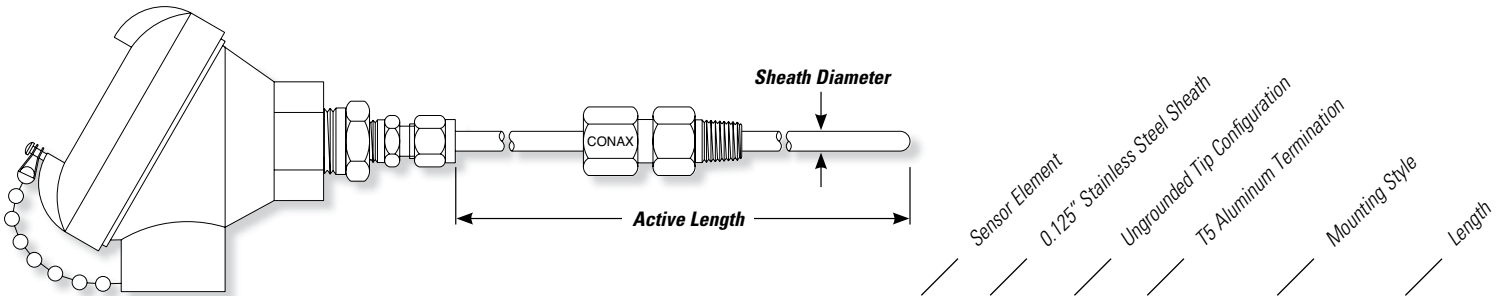

Progressive Description Example: **J-SS12-U-T5AL(PG2AL)-12.00"**



<p>Specify Termination Style</p> <div style="margin-bottom: 10px;"> <p>T5AL - Aluminum T5CI - Cast Iron</p> <ul style="list-style-type: none"> • NEMA 4 rated • Conduit port 3/4 NPT </div> <div style="margin-bottom: 10px;"> <p>T5SS</p> <ul style="list-style-type: none"> • NEMA 4X rated • 316 stainless steel construction • Conduit port 3/4 NPT </div> <div style="margin-bottom: 10px;"> <p>T7</p> <ul style="list-style-type: none"> • Weather proof • Aluminum conduit box accommodates up to 8 terminals • Conduit port 3/4 NPT </div> <div style="margin-bottom: 10px;"> <p>T8E</p> <ul style="list-style-type: none"> • Explosion proof rating Class I, Group B, C & D Class II, Group E, F & G Class III • Gray iron body with aluminum screw cover • NEMA 4 rated • Conduit port 1/2 NPT </div>	<p>Specify Mounting Style</p> <div style="margin-bottom: 10px;"> <p>T11</p> <ul style="list-style-type: none"> • Weather proof • Aluminum construction • Conduit port 1/2 NPT </div> <div style="margin-bottom: 10px;"> <p>T11PL</p> <ul style="list-style-type: none"> • Weather proof • Plastic construction • Conduit port 1/2 NPSM </div> <div style="margin-bottom: 10px;"> <p>T12</p> <ul style="list-style-type: none"> • Weather proof • Aluminum construction • Flip-top head • Conduit port 1/2 NPT </div> <div style="margin-bottom: 10px;"> <p>T13T</p> <ul style="list-style-type: none"> • FDA compliant, NEMA 4X rated • White, unpigmented polypropylene construction • 4 terminal posts • Conduit port 3/4 NPT </div> <div style="margin-bottom: 10px;"> <p>T15EAL - Aluminum T15ESS - Stainless Steel T15EAL(ATEX)</p> <ul style="list-style-type: none"> • Explosion Proof rating Class 1, Division 1, Groups B, C and D and Dust Proof/Ignition Proof rating for Class II, Division 1, Group E, F & G • Ratings: T15EAL – NEMA 4, T15ESS – NEMA 4X • Conduit port 3/4 NPT </div>	<p>Specify Length in Inches (required)</p>
	<p>Packing Gland</p> <div style="margin-bottom: 10px;"> <p>MPG</p> <ul style="list-style-type: none"> • For 0.125" and 0.187" diameter sheath • Stainless steel construction • Mounting thread 1/8 NPT </div> <p>MPGAL – Lava sealant MPGAT – Teflon sealant MPGAN – Neoprene sealant MPGAV – Viton sealant MPGAG – Grafoil sealant</p> <div style="margin-bottom: 10px;"> <p>PG2</p> <ul style="list-style-type: none"> • For 0.125", 0.187" and 0.250" diameter sheath • Stainless steel construction • Mounting thread 1/4 NPT </div> <p>PG2AL – Lava sealant PG2AT – Teflon sealant PG2AN – Neoprene sealant PG2AV – Viton sealant PG2AG – Grafoil sealant</p> <div style="margin-bottom: 10px;"> <p>PG4</p> <ul style="list-style-type: none"> • For 0.250" and 0.375" diameter sheath • Stainless steel construction • Mounting thread 1/2 NPT </div> <p>PG4AL – Lava sealant PG4AT – Teflon sealant PG4AN – Neoprene sealant PG4AV – Viton sealant PG4AG – Grafoil sealant</p>	<p>Midlock Gland</p> <div style="margin-bottom: 10px;"> <p>MK125A</p> <ul style="list-style-type: none"> • For 0.125" diameter sheath • Stainless steel construction • Stainless steel ferrule • Mounting thread 1/8 NPT </div> <div style="margin-bottom: 10px;"> <p>MK187A</p> <ul style="list-style-type: none"> • For 0.187" diameter sheath • Stainless steel construction • Stainless steel ferrule • Mounting thread 1/8 NPT </div> <div style="margin-bottom: 10px;"> <p>MK250A</p> <ul style="list-style-type: none"> • For 0.250" diameter sheath • Stainless steel construction • Stainless steel ferrule • Mounting thread 1/4 NPT </div> <div style="margin-bottom: 10px;"> <p>MK375A</p> <ul style="list-style-type: none"> • For 0.375" diameter sheath • Stainless steel construction • Stainless steel ferrule • Mounting thread 1/2 NPT </div>

Note: For sealant material details, see page 37.

This assembly may be purchased without the mounting fitting. Omit the mounting style from the description. The catalog description in this case would be J-SS12-U-T5AL-12.00".

Note: For additional terminal head types and detailed descriptions, see pages 43-47.

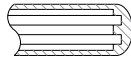
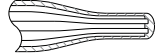
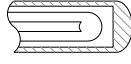
Conax spring-loaded assemblies are used to maintain positive contact between the sensor tip and the surface to be monitored. Conax supplies a number of styles of spring-loaded assemblies to meet application needs. Spring-loaded assemblies can be provided with all terminal heads. In addition, the T11SL model provides a spring-loaded assembly built into the T11 aluminum terminal head. This allows complete disassembly and removal of the sensor probe without dismantling the terminal head from the conduit or the vessel. For detailed information on these mounting styles, see pages 40-41.

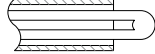
Specify Sensor Element	Specify Sheath Material	Specify Sheath Diameter	Specify Tip Configuration
<p>J – Iron/Constantan</p> <ul style="list-style-type: none"> • 32° F to +1400° F • 0° C to +760° C <p>K – Chromel/Alumel</p> <ul style="list-style-type: none"> • -328° F to +2300° F • -200° C to +1260° C <p>E – Chromel/Constantan</p> <ul style="list-style-type: none"> • -328° F to +1600° F • -200° C to +870° C <p>T – Copper/Constantan</p> <ul style="list-style-type: none"> • -328° F to +700° F • -200° C to +370° C <p>N – Nicrosil/Nisil</p> <ul style="list-style-type: none"> • 32° F to +2300° F • 0° C to +1260° C <p>S – Platinum-10% Rhodium/Platinum</p> <ul style="list-style-type: none"> • 32° F to +2700° F • 0° C to +1480° C <p>R – Platinum-13% Rhodium/Platinum</p> <ul style="list-style-type: none"> • 32° F to +2700° F • 0° C to +1480° C <p>B – Platinum-30% Rhodium/Platinum-6% Rhodium</p> <ul style="list-style-type: none"> • 1600° F to +3100° F • 870° C to +1700° C <p>C – Tungsten-5% Rhenium/Tungsten-26% Rhenium</p> <ul style="list-style-type: none"> • 32° F to +4200° F • 0° C to +2315° C 	<p>SS – 304 Stainless Steel</p> <ul style="list-style-type: none"> • Maximum service temperature: +1650° F (900° C) <p>316SS – 316 Stainless Steel</p> <ul style="list-style-type: none"> • Maximum service temperature: +1650° F (900° C) <p>INC – Inconel 600</p> <ul style="list-style-type: none"> • Maximum service temperature: +2100° F (1150° C) <p>Alternate Materials</p> <p>310SS – 310 Stainless Steel 188HN – Haynes 188 214HN – Haynes 214 230HN – Haynes 230 HC – Hastelloy C HX – Hastelloy X TI – Titanium TA – Tantalum PLT – Platinum</p>	<p>6 = 0.062" diameter</p> <p>12 = 0.125" diameter</p> <p>18 = 0.187" diameter</p> <p>25 = 0.250" diameter</p> <p><i>Note: The SL6 is the only spring load mounting style available for the 0.062" diameter.</i></p>	 <p>G – Grounded</p> <p>G – Single, Grounded 2G – Dual, Grounded 3G – Triple, Grounded</p>  <p>GR – Grounded, Reduced</p>  <p>U – Ungrounded</p> <p>U – Single, Ungrounded 2U – Dual, Ungrounded 3U – Triple, Ungrounded</p>  <p>UR – Ungrounded, Reduced</p>  <p>B – Bare Wire</p>

Certain calibrations and wire configurations (dual and triple) may not be available in all sheath materials and diameters. Consult factory for details.

Note: For more information on tip configurations, see page 23.

Special limits of error are designated by a double catalog letter, e.g. JJ.

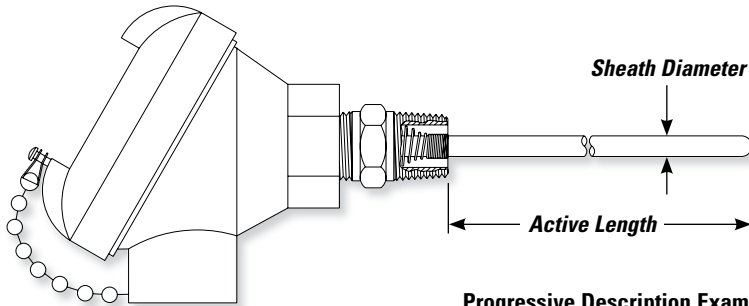

Progressive Description Example: **J-SS12-U-T5AL(CSLW)-12.00"**

Specify Termination Style



T5AL - Aluminum
T5CI - Cast Iron

- NEMA 4 rated
- Conduit port 3/4 NPT



T5SS

- NEMA 4X rated
- 316 stainless steel construction
- Conduit port 3/4 NPT



T7

- Weather proof
- Aluminum conduit box accommodates up to 8 terminals
- Conduit port 3/4 NPT



T8E

- Explosion proof rating Class I, Group B, C & D Class II, Group E, F & G Class III
- Gray iron body with aluminum screw cover
- NEMA 4 rated
- Conduit port 1/2 NPT



T11SL

- Weather proof
- Aluminum construction
- Built-in spring loaded assembly
- Conduit port 1/2 NPT



T11

- Weather proof
- Aluminum construction
- Conduit port 1/2 NPT



T11PL

- Weather proof
- Plastic construction
- Conduit port 1/2 NPT



T12

- Weather proof
- Aluminum construction
- Flip-top head
- Conduit port 1/2 NPT



T13T

- FDA compliant, NEMA 4X rated
- White, unpigmented polypropylene construction
- 4 terminal posts
- Conduit port 3/4 NPT



T15EAL - Aluminum
T15ESS - Stainless Steel

T15EAL(ATEX)

- Explosion Proof rating Class 1, Division 1, Groups B, C and D and Dust Proof/Ignition Proof rating for Class II, Division 1, Group E, F & G
- Ratings: T15EAL – NEMA 4, T15ESS – NEMA 4X
- Conduit port 3/4 NPT

Specify Mounting Style

CSLW

- For 0.125", 0.187" and 0.250" diameter sheaths
- Stainless steel construction
- Mounting thread 1/2 NPT

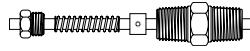

SLAN

- For 0.125", 0.187" and 0.250" diameter sheaths
- Stainless steel construction
- Mounting thread 1/2 NPT
- Probe position can be adjusted in the field

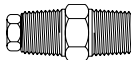

SLANS

- For 0.250" diameter sheath
- Includes Viton O-ring
- Stainless steel construction
- Mounting thread 1/2 NPT
- Probe position can be adjusted in the field

Specify Length in Inches (required)

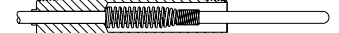

SLN

- For 0.125", 0.187" and 0.250" diameter sheath
- Mounting thread 1/2 NPT
- Most durable

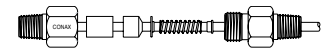

SL

- Spring-loaded packing gland
- Spring travel: 1/4" to 3/8"
- 2-8 pounds spring pressure
- Stainless steel construction, Teflon sealant
- Available with B cap for direct mount
- Additional dimensional data required, see page 40.

SL6

- For 0.062" diameter sheath
- Mounting thread 1/8 NPT

SL12

- For 0.125" diameter sheath
- Mounting thread 1/8 NPT

SL18

- For 0.187" diameter sheath
- Mounting thread 1/4 NPT

SL25

- For 0.250" diameter sheath
- Mounting thread 1/2 NPT
- Optional 1/4 NPT mounting thread is available. Consult factory.

For additional information on spring-loaded mounting styles, see page 40-41.

Note: For additional terminal head types and detailed descriptions, see pages 43-47.

This exclusive Conax design provides a practically unbreakable connection between the leadwire and the probe lead. The T3 epoxy-filled transition is supplied with silicone-impregnated fiberglass insulation thermocouple wire as standard. AWG 20 wire is provided for sheath diameters of 0.125" to 0.375"; AWG 24 wire is provided for sheath diameters of 0.040" and 0.062".

T4 termination provides a stainless steel overbraid for maximum flexibility and abrasion resistance. The overbraid is embedded in the epoxy to ensure mechanical strength. Standard extension leads are 24" long. Longer leads are available on request.

Specify Sensor Element	Specify Sheath Material	Specify Sheath Diameter	Specify Tip Configuration
<p>J – Iron/Constantan</p> <ul style="list-style-type: none"> • 32° F to +1400° F • 0° C to +760° C <p>K – Chromel/Alumel</p> <ul style="list-style-type: none"> • -328° F to +2300° F • -200° C to +1260° C <p>E – Chromel/Constantan</p> <ul style="list-style-type: none"> • -328° F to +1600° F • -200° C to +870° C <p>T – Copper/Constantan</p> <ul style="list-style-type: none"> • -328° F to +700° F • -200° C to +370° C <p>N – Nicrosil/Nisil</p> <ul style="list-style-type: none"> • 32° F to +2300° F • 0° C to +1260° C <p>S – Platinum-10% Rhodium/Platinum</p> <ul style="list-style-type: none"> • 32° F to +2700° F • 0° C to +1480° C <p>R – Platinum-13% Rhodium/Platinum</p> <ul style="list-style-type: none"> • 32° F to +2700° F • 0° C to +1480° C <p>B – Platinum-30% Rhodium/Platinum-6% Rhodium</p> <ul style="list-style-type: none"> • 1600° F to +3100° F • 870° C to +1700° C <p>C – Tungsten-5% Rhenium/Tungsten-26% Rhenium</p> <ul style="list-style-type: none"> • 32° F to +4200° F • 0° C to +2315° C 	<p>SS – 304 Stainless Steel</p> <ul style="list-style-type: none"> • Maximum service temperature: +1650° F (900° C) <p>316SS – 316 Stainless Steel</p> <ul style="list-style-type: none"> • Maximum service temperature: +1650° F (900° C) <p>INC – Inconel 600</p> <ul style="list-style-type: none"> • Maximum service temperature: +2100° F (1150° C) <p>Alternate Materials</p> <p>310SS – 310 Stainless Steel 188HN – Haynes 188 214HN – Haynes 214 230HN – Haynes 230 HC – Hastelloy C HX – Hastelloy X TI – Titanium TA – Tantalum PLT – Platinum</p>	<p>4 = 0.040" diameter</p> <p>6 = 0.062" diameter</p> <p>12 = 0.125" diameter</p> <p>18 = 0.187" diameter</p> <p>25 = 0.250" diameter</p> <p>37 = 0.375" diameter</p>	<p>G – Grounded</p> <p>G – Single, Grounded 2G – Dual, Grounded 3G – Triple, Grounded</p> <p>GR – Grounded, Reduced</p> <p>U – Ungrounded</p> <p>U – Single, Ungrounded 2U – Dual, Ungrounded 3U – Triple, Ungrounded</p> <p>UR – Ungrounded, Reduced</p> <p>B – Bare Wire</p>

Certain calibrations and wire configurations (dual and triple) may not be available in all sheath materials and diameters. Consult factory for details.

Note: For more information on tip configurations, see page 23.

Special limits of error are designated by a double catalog letter, e.g. JJ.

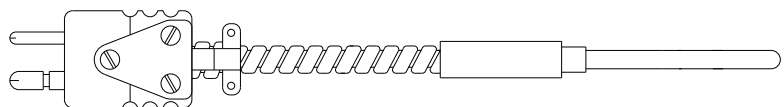

T3 with armored cable, see page 76. (Also available without armor.)

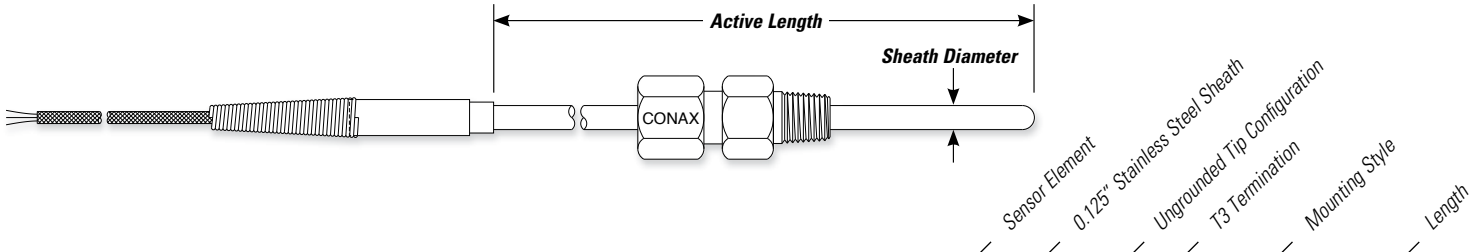

Progressive Description Example: **J-SS12-U-T3-PG2AL-12.00"**

Specify Termination Style

T3

- Fiberglass/silicone impregnated leadwire insulation
- Service temperature: 300° F (150° C)

T4

- Fiberglass/silicone impregnated leadwire insulation
- Stainless steel overbraid
- Service temperature: 300° F (150° C)

T3(HT)

- Fiberglass/silicone impregnated leadwire insulation
- High-temperature encapsulant
- Service temperature: 900° F (482° C)

T4(HT)

- Fiberglass/silicone impregnated leadwire insulation
- Stainless steel overbraid
- High-temperature encapsulant
- Service temperature: 900° F (482° C)

For longer lead length, specify in feet, rounded up to the nearest foot. Example: T3(3 FT)

Optional leadwire insulation types are available. Example: PVC requested – T3(3 FT-PVC). Consult factory for availability.

For detailed descriptions of termination styles, see pages 42-43.

Specify Mounting Style (optional)

Packing Gland

- MIC**
- For 0.040" and 0.062" diameter sheath
 - Stainless steel construction
 - Mounting thread 1/16 NPT

- MICAL – Lava sealant**
MICAT – Teflon sealant
MICAG – Grafoil sealant
 (not available for 0.040" diameter)

- MPG**
- For 0.040", 0.062", 0.125" and 0.187" diameter sheath
 - Stainless steel construction
 - Mounting thread 1/8 NPT

- MPGAL – Lava sealant**
MPGAT – Teflon sealant
MPGAN – Neoprene sealant
MPGAV – Viton sealant
MPGAG – Grafoil sealant
 (not available for 0.040" diameter)

- PG2**
- For 0.125", 0.187" and 0.250" diameter sheath
 - Stainless steel construction
 - Mounting thread 1/4 NPT

- PG2AL – Lava sealant**
PG2AT – Teflon sealant
PG2AN – Neoprene sealant
PG2AV – Viton sealant
PG2AG – Grafoil sealant

- PG4**
- For 0.250" and 0.375" diameter sheath
 - Stainless steel construction
 - Mounting thread 1/2 NPT

- PG4AL – Lava sealant**
PG4AT – Teflon sealant
PG4AN – Neoprene sealant
PG4AV – Viton sealant
PG4AG – Grafoil sealant

- Midlock Gland**
- MK062A**
- For 0.062" diameter sheath
 - Stainless steel construction
 - Stainless steel ferrule
 - Mounting thread 1/8 NPT

- MK125A**
- For 0.125" diameter sheath
 - Stainless steel construction
 - Stainless steel ferrule
 - Mounting thread 1/8 NPT

- MK187A**
- For 0.187" diameter sheath
 - Stainless steel construction
 - Stainless steel ferrule
 - Mounting thread 1/8 NPT

Specify Length in Inches (required)

- MK250A**
- For 0.250" diameter sheath
 - Stainless steel construction
 - Stainless steel ferrule
 - Mounting thread 1/4 NPT

- MK375A**
- For 0.375" diameter sheath
 - Stainless steel construction
 - Stainless steel ferrule
 - Mounting thread 1/2 NPT

- Spring-Load**
- CSLP**
- For 0.125", 0.187" and 0.250" diameter sheaths
 - Stainless steel construction
 - Mounting thread 1/2 NPT

Note: For sealant material details, see page 37.

Conax polarized plug and jack assembly bodies are made from molded glass-filled thermoset compounds, with contacts constructed of thermocouple alloy materials. Polarity marks are molded in the bodies for installation assistance, and male and female assemblies are color coded with ISA calibration coding. A metal ferrule tube adapter secures the probe in place, and a wire clamp is used to hold the wire. Standard assemblies are designed to operate in temperatures up to 300° F (150° C). High temperature assemblies operate up to 800° F (427° C) and are color-coded red. Individual plugs, jacks, tube adapters and wire clamps are also available.

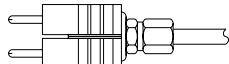
Specify Sensor Element	Specify Sheath Material	Specify Sheath Diameter	Specify Tip Configuration
<p>J – Iron/Constantan</p> <ul style="list-style-type: none"> • 32° F to +1400° F • 0° C to +760° C <p>K – Chromel/Alumel</p> <ul style="list-style-type: none"> • -328° F to +2300° F • -200° C to +1260° C <p>E – Chromel/Constantan</p> <ul style="list-style-type: none"> • -328° F to +1600° F • -200° C to +870° C <p>T – Copper/Constantan</p> <ul style="list-style-type: none"> • -328° F to +700° F • -200° C to +370° C <p>N – Nicrosil/Nisil</p> <ul style="list-style-type: none"> • 32° F to +2300° F • 0° C to +1260° C <p>S – Platinum-10% Rhodium/Platinum</p> <ul style="list-style-type: none"> • 32° F to +2700° F • 0° C to +1480° C <p>R – Platinum-13% Rhodium/Platinum</p> <ul style="list-style-type: none"> • 32° F to +2700° F • 0° C to +1480° C <p>B – Platinum-30% Rhodium/Platinum-6% Rhodium</p> <ul style="list-style-type: none"> • 1600° F to +3100° F • 870° C to +1700° C <p>C – Tungsten-5% Rhenium/Tungsten-26% Rhenium</p> <ul style="list-style-type: none"> • 32° F to +4200° F • 0° C to +2315° C 	<p>SS – 304 Stainless Steel</p> <ul style="list-style-type: none"> • Maximum service temperature: +1650° F (900° C) <p>316SS – 316 Stainless Steel</p> <ul style="list-style-type: none"> • Maximum service temperature: +1650° F (900° C) <p>INC – Inconel 600</p> <ul style="list-style-type: none"> • Maximum service temperature: +2100° F (1150° C) <p>Alternate Materials</p> <p>310SS – 310 Stainless Steel 188HN – Haynes 188 214HN – Haynes 214 230HN – Haynes 230 HC – Hastelloy C HX – Hastelloy X TI – Titanium TA – Tantalum PLT – Platinum</p>	<p>4 = 0.040" diameter</p> <p>6 = 0.062" diameter</p> <p>12 = 0.125" diameter</p> <p>18 = 0.187" diameter</p> <p>25 = 0.250" diameter</p> <p>37 = 0.375" diameter</p>	<p>G – Grounded</p> <p>G – Single, Grounded 2G – Dual, Grounded 3G – Triple, Grounded</p> <p>GR – Grounded, Reduced</p> <p>U – Ungrounded</p> <p>U – Single, Ungrounded 2U – Dual, Ungrounded 3U – Triple, Ungrounded</p> <p>UR – Ungrounded, Reduced</p> <p>B – Bare Wire</p>
<p><i>Special limits of error are designated by a double catalog letter, e.g. JJ.</i></p>	<p><i>Certain calibrations and wire configurations (dual and triple) may not be available in all sheath materials and diameters. Consult factory for details.</i></p>	<p> Dual styles available</p> <p><i>Miniatures are not available in dual construction.</i></p>	

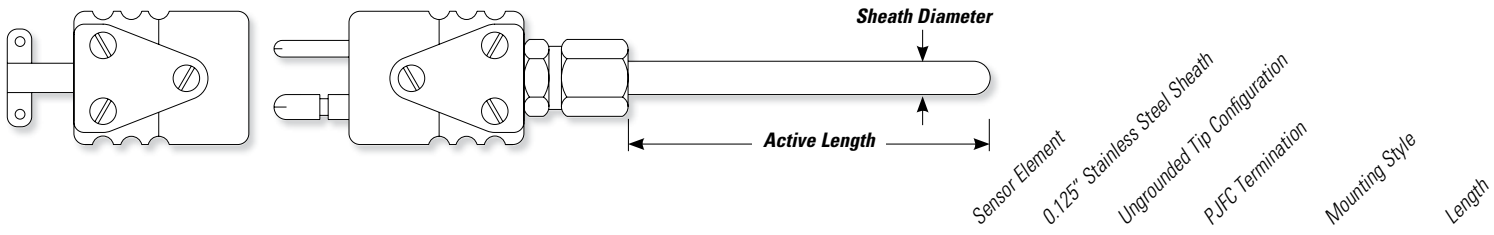



Progressive Description Example: **J-SS12-U-PJFC-PG2AL-12.00"**

<p>Specify Termination Style</p> <p>PJ – Male plug only PJHT – Male plug only, high temperature</p> <p>PF – Female jack only PFHT – Female jack only, high temperature</p> <p>PJF – Male plug & female jack PJFHT – Male plug & female jack, high temperature</p> <p>PJFC – Plug, jack & wire clamp PJFCHT – Plug, jack & wire clamp, high temperature</p> <p>MPJ – Miniature male plug only MPJHT – Miniature male plug only, high temperature</p> <p>MPF – Miniature female jack only MPFHT – Miniature female jack only, high temperature</p> <p>MPJF – Miniature male plug & female jack MPJFHT – Miniature male plug & female jack, high temperature</p> <p>MPJFC – Miniature plug, jack & wire clamp MPJFCHT – Miniature plug, jack & wire clamp, high temperature</p>	<p>Specify Mounting Style (optional)</p> <p>Packing Gland</p> <p>MIC</p> <ul style="list-style-type: none"> • For 0.040" and 0.062" diameter sheath • Stainless steel construction • Mounting thread 1/16 NPT <p>MICAL – Lava sealant MICAT – Teflon sealant MICAG – Grafoil sealant <i>(not available for 0.040" diameter)</i></p> <p>MPG</p> <ul style="list-style-type: none"> • For 0.040", 0.062", 0.125" and 0.187" diameter sheath • Stainless steel construction • Mounting thread 1/8 NPT <p>MPGAL – Lava sealant MPGAT – Teflon sealant MPGAN – Neoprene sealant MPGAV – Viton sealant MPGAG – Grafoil sealant <i>(not available for 0.040" diameter)</i></p> <p>PG2</p> <ul style="list-style-type: none"> • For 0.125", 0.187" and 0.250" diameter sheath • Stainless steel construction • Mounting thread 1/4 NPT <p>PG2AL – Lava sealant PG2AT – Teflon sealant PG2AN – Neoprene sealant PG2AV – Viton sealant PG2AG – Grafoil sealant</p>	<p>Specify Length in Inches (required)</p> <p>PG4</p> <ul style="list-style-type: none"> • For 0.250" and 0.375" diameter sheath • Stainless steel construction • Mounting thread 1/2 NPT <p>PG4AL – Lava sealant PG4AT – Teflon sealant PG4AN – Neoprene sealant PG4AV – Viton sealant PG4AG – Grafoil sealant</p> <p>Midlock Gland</p> <p>MK062A</p> <ul style="list-style-type: none"> • For 0.062" diameter sheath • Stainless steel construction • Stainless steel ferrule • Mounting thread 1/8 NPT <p>MK125A</p> <ul style="list-style-type: none"> • For 0.125" diameter sheath • Stainless steel construction • Stainless steel ferrule • Mounting thread 1/8 NPT <p>MK187A</p> <ul style="list-style-type: none"> • For 0.187" diameter sheath • Stainless steel construction • Stainless steel ferrule • Mounting thread 1/8 NPT
---	---	---

For detailed descriptions of termination styles, see page 46.

Note: For sealant material details, see page 37.

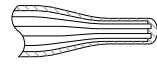
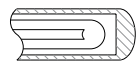
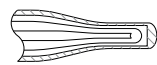
Conax B-Series heads are compact, lightweight terminal heads that provide convenient hook-up of customer extension wire. The cap and body are nickel-plated to resist corrosion. The ceramic terminal block contains zinc-plated brass terminal posts that accept up to 14 AWG wire. Bayonet-style cover allows easy access to the terminal posts. B-Series heads are provided in direct or adjustable mounting styles.

<p>Specify Sensor Element</p> <p>J – Iron/Constantan • 32° F to +1400° F • 0° C to +760° C</p> <p>K – Chromel/Alumel • -328° F to +2300° F • -200° C to +1260° C</p> <p>E – Chromel/Constantan • -328° F to +1600° F • -200° C to +870° C</p> <p>T – Copper/Constantan • -328° F to +700° F • -200° C to +370° C</p> <p>N – Nicrosil/Nisil • 32° F to +2300° F • 0° C to +1260° C</p> <p>S – Platinum-10% Rhodium/Platinum • 32° F to +2700° F • 0° C to +1480° C</p> <p>R – Platinum-13% Rhodium/Platinum • 32° F to +2700° F • 0° C to +1480° C</p> <p>B – Platinum-30% Rhodium/Platinum-6% Rhodium • 1600° F to +3100° F • 870° C to +1700° C</p> <p>C – Tungsten-5% Rhenium/Tungsten-26% Rhenium • 32° F to +4200° F • 0° C to +2315° C</p>	<p>Specify Sheath Material</p> <p>SS – 304 Stainless Steel • Maximum service temperature: +1650° F (900° C)</p> <p>316SS – 316 Stainless Steel • Maximum service temperature: +1650° F (900° C)</p> <p>INC – Inconel 600 • Maximum service temperature: +2100° F (1150° C)</p> <p>Alternate Materials</p> <p>310SS – 310 Stainless Steel 188HN – Haynes 188 214HN – Haynes 214 230HN – Haynes 230 HC – Hastelloy C HX – Hastelloy X TI – Titanium TA – Tantalum PLT – Platinum</p> <p><i>Certain calibrations and wire configurations (dual and triple) may not be available in all sheath materials and diameters. Consult factory for details.</i></p>	<p>Specify Sheath Diameter</p> <p>4 = 0.040" diameter 6 = 0.062" diameter 12 = 0.125" diameter 18 = 0.187" diameter 25 = 0.250" diameter</p>	<p>Specify Tip Configuration</p>  <p>G – Grounded G – Single, Grounded 2G – Dual, Grounded</p>  <p>GR – Grounded, Reduced</p>  <p>U – Ungrounded U – Single, Ungrounded 2U – Dual, Ungrounded</p>  <p>UR – Ungrounded, Reduced</p>  <p>B – Bare Wire</p> <p><i>Note: For more information on tip configurations, see page 23.</i></p>
---	---	--	--

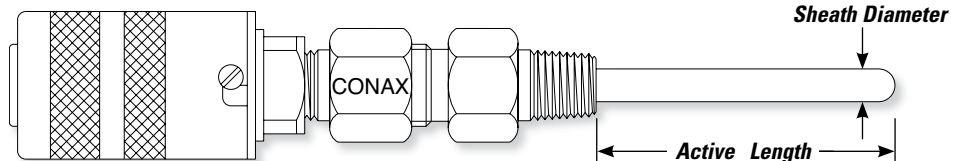

Special limits of error are designated by a double catalog letter, e.g. JJ.

Direct Mount
Progressive Description Example: J-SS12-U-B2(PG2BN) - 12.00"

--- Sensor Element
 --- 0.125" Stainless Steel Sheath
 --- Ungrounded Tip Configuration
 --- B2 Termination
 --- Mounting Style
 --- Length

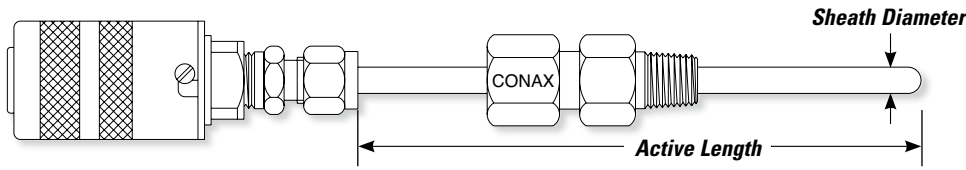

Adjustable Mount

Progressive Description Example: **J-SS12-U-B2-PG2AL-12.00"**

Sensor Element
0.125" Stainless Steel Sheath
Ungrounded Tip Configuration
B2 Termination
Mounting Style
Length

Specify Termination Style

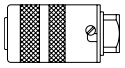

B2

- Standard 2-wire
- Maximum service temperature is 200° F (93.3° C) with grommet and O-ring; 750° F (400° C) with grommet and O-ring removed

B4

- Standard 4-wire
- Maximum service temperature is 200° F (93.3° C) with grommet and O-ring; 750° F (400° C) with grommet and O-ring removed

For detailed descriptions of termination styles, see page 46.

Specify Mounting Style

DIRECT MOUNT Packing Gland



- For 0.040", 0.062", 0.125" and 0.187" diameter sheath
- Stainless steel construction
- Mounting thread 1/8 NPT

- MPGBL** – Lava sealant
- MPGBT** – Teflon sealant
- MPGBN** – Neoprene sealant
- MPGBV** – Viton sealant
- MPGBG** – Grafoil sealant

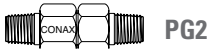

- For 0.125", 0.187" and 0.250" diameter sheath
- Stainless steel construction
- Mounting thread 1/4 NPT

- PG2BL** – Lava sealant
- PG2BT** – Teflon sealant
- PG2BN** – Neoprene sealant
- PG2BV** – Viton sealant
- PG2BG** – Grafoil sealant



- For 0.125", 0.187" & 0.250" diameter sheath
- 316 stainless steel construction
- Mounting thread 1/4 NPT
- Sheath welded to fitting

ADJUSTABLE MOUNT (optional) Packing Gland



- For 0.040" and 0.062" diameter sheath
- Stainless steel construction
- Mounting thread 1/16 NPT

- MICAL** – Lava sealant
- MICAT** – Teflon sealant
- MICAG** – Grafoil sealant
(not available for 0.040" diameter)



- For 0.040", 0.062", 0.125" and 0.187" diameter sheath
- Stainless steel construction
- Mounting thread 1/8 NPT

- MPGAL** – Lava sealant
- MPGAT** – Teflon sealant
- MPGAN** – Neoprene sealant
- MPGAV** – Viton sealant
- MPGAG** – Grafoil sealant

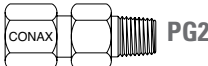

- For 0.125", 0.187" and 0.250" diameter sheath
- Stainless steel construction
- Mounting thread 1/4 NPT

- PG2AL** – Lava sealant
- PG2AT** – Teflon sealant
- PG2AN** – Neoprene sealant
- PG2AV** – Viton sealant
- PG2AG** – Grafoil sealant

Specify Length in Inches (required)

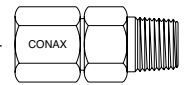

- For 0.250" diameter sheath
- Stainless steel construction
- Mounting thread 1/2 NPT

- PG4AL** – Lava sealant
- PG4AT** – Teflon sealant
- PG4AN** – Neoprene sealant
- PG4AV** – Viton sealant
- PG4AG** – Grafoil sealant

Midlock Gland



- For 0.062" diameter sheath
- Stainless steel construction
- Stainless steel ferrule
- Mounting thread 1/8 NPT



- For 0.125" diameter sheath
- Stainless steel construction
- Stainless steel ferrule
- Mounting thread 1/8 NPT



- For 0.187" diameter sheath
- Stainless steel construction
- Stainless steel ferrule
- Mounting thread 1/8 NPT



- For 0.250" diameter sheath
- Stainless steel construction
- Stainless steel ferrule
- Mounting thread 1/4 NPT

Note: For sealant material details, see page 37.

This catalog presents the most commonly used methods to mount sensor probes. Conax manufactures a broad range of pressure/vacuum compression seals for specific uses. For a complete selection of mounting methods and compression seal fittings, request Conax Pressure and Vacuum Sealing Assemblies catalog #5001 or visit www.conaxtechnologies.com

Conax Compression Seal Fittings conform to the Standard Engineering Practice (SEP) requirements of the European Pressure Equipment Directive (PED) 97/23/EC. Contact Conax Technologies for further information.

Conax Compression Seal Fitting – Catalog Types MIC, MPG and PG

This stainless steel, single bore compression seal fitting seals sheathed thermocouples, RTDs or other probes against gases or liquids. Conax “soft sealant” technology uses a compressible material, allowing the seal to be untorqued to adjust the probe immersion, then retorqued to re-establish the seal.

- Pressure: Vacuum to 10,000 psi (690 bar)
- Temperature Range: -400° F to +1600° F (-240° C to +870° C)
- Simple assembly, field adjustable
- Replaceable sealant permits repeated use of fitting
- Minimizes tube stress concentration



PRESSURE RATING GUIDE @ 68°F (20°C)

Catalog Number	Pressure Rating by Sealant Type (PSI)**									
	Neoprene		Viton		Teflon		Lava		Grafoil	
	PSIG	BAR	PSIG	BAR	PSIG	BAR	PSIG	BAR	PSIG	BAR
MIC-040	—	—	—	—	3,200	220	8,000	551	—	—
MIC-062	—	—	—	—	3,200	220	8,000	551	10,000	690
MPG-040	2,000	138	1,600	110	1,600	110	2,800	193	1,600	110
MPG-062	1,600	110	2,800	193	1,600	110	3,200	220	2,000	138
MPG-125	1,200	83	1,200	83	800	55	2,000	138	2,400	165
MPG-187	1,200	83	1,500	103	1,500	103	2,000	138	800	55
PG2-125	2,800	193	2,800	193	1,600	110	9,000	620	8,000	551
PG2-187	2,000	138	4,500	310	1,600	110	8,800	607	4,000	276
PG2-250	1,000	69	2,000	138	800	55	7,500	517	4,000	276
PG4-250	1,500	103	1,500	103	1,600	110	10,000	690	7,500	517
PG4-375	1,200	83	500	34	1,400	96	7,500	517	4,500	310

SPECIFICATIONS

Catalog Number	Tube or Probe Diameter***		Thread NPT	Length				Hex Size		TORQUE** (Ft-Lbs except as noted)			
	IN	MM		A	B	IN	MM	IN	MM	Neoprene/Viton	Teflon	Lava	Grafoil
MIC-040-*	.040	1.02	1/16	.94	23.8	N.A.	N.A.	.375	9.5	—	7-9 in-lbs	45-50 in-lbs	—
MIC-062-*	.062	1.57	1/16	.94	23.8	N.A.	N.A.	.375	9.5	—	7-9 in-lbs	45-50 in-lbs	45-50 in-lbs
MPG-040-*	.040	1.02	1/8	1.19	30.2	1.56	39.7	.50	12.7	55-60 in-lbs	55-60 in-lbs	75-80 in-lbs	55-60 in-lbs
MPG-062-*	.062	1.57	1/8	1.19	30.2	1.56	39.7	.50	12.7	55-60 in-lbs	55-60 in-lbs	75-80 in-lbs	55-60 in-lbs
MPG-125-*	.125	3.18	1/8	1.19	30.2	1.56	39.7	.50	12.7	55-60 in-lbs	55-60 in-lbs	75-80 in-lbs	55-60 in-lbs
MPG-187-*	.187	4.75	1/8	1.19	30.2	1.56	39.7	.50	12.7	55-60 in-lbs	55-60 in-lbs	75-80 in-lbs	55-60 in-lbs
PG2-125-*	.125	3.18	1/4	2.00	50.8	2.63	66.7	.75	19.1	30-35	15-20	40-45	35-40
PG2-187-*	.187	4.75	1/4	2.00	50.8	2.63	66.7	.75	19.1	30-35	15-20	40-45	35-40
PG2-250-*	.250	6.35	1/4	2.00	50.8	2.63	66.7	.75	19.1	30-35	15-20	40-45	35-40
PG4-250-*	.250	6.35	1/2	2.56	65.0	3.31	84.1	1.00	25.4	55-60	55-60	125-140	90-100
PG4-375-*	.375	9.53	1/2	2.56	65.0	3.31	84.1	1.00	25.4	55-60	55-60	125-140	90-100

* Cap Style A or B

** All pressure and torque ratings determined at 68°F with solid stainless steel rod used as the element.

*** Tolerance of tube or probe diameter, ±0.005". Deviation from the nominal may affect pressure ratings.

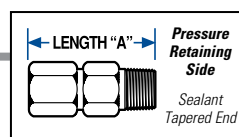

Type A has mounting thread only.

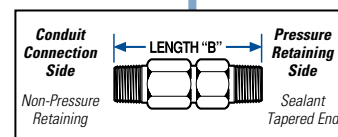

Type B has cap end threaded.

Conax Metal Ferrule Compression Seal Fitting – Catalog Type MK



This all stainless steel assembly for sealing gases and liquids is easy to use. Simply open the compression seal fitting and slide the assembled fitting over the tube or probe. Tighten at the desired location. The ferrule is deformed against the probe and makes a seal without cutting the sheath surface.

- Pressure: Vacuum to 10,000 psi (690 bar)
- Temperature Range: Cryogenic to +1600° F (+870° C)
- Metal-to-metal seal
- Single ferrule is self-aligning (no lost pieces)
- Suitable for high vibration applications

Specifications - MK

Catalog Number	Tube/Probe Diameter		Thread NPT IN	Length 'A'		Hex Size				Pressure Rating		Torque	
	IN	MM		IN	MM	Body IN	Cap IN	Body MM	Cap MM	PSIG	BAR	Ft-lbs	Nm
MK-062-A	0.062	1.57	1/8	1.19	30.2	0.500	0.500	12.7	12.7	10,000	689	10	14
MK-125-A	0.125	3.18	1/8	1.19	30.2	0.500	0.500	12.7	12.7	10,000	689	12	16
MK-187-A	0.187	4.75	1/8	1.19	30.2	0.500	0.500	12.7	12.7	10,000	689	18	24
MK-250-A	0.250	6.35	1/4	1.63	41.3	0.625	0.625	15.9	15.9	10,000	689	30	41
MK-375-A	0.375	9.53	1/2	2.00	50.8	1.000	0.750	25.4	19.1	10,000	689	50	68

All pressure and torque ratings were determined at 68°F (20°C) using stainless steel rod as the element. Pressure ratings may degrade at higher temperatures. Pressure rating guide values are provided for glands with elements restrained by the compressed sealant. Higher pressure may be attained with additional element restraints. Tolerance of tube or probe diameters is ±0.005". Deviation from the nominal may affect the pressure rating. For proper assembly of these sealing glands, see the Assembly Instructions provided on pages 106-119.

Sealant Selection Guide

Sealant Material	Temperature Range	Type of Material	Feature
Neoprene	-40° F to +200° F (-40° C to +93° C)	Synthetic Rubber (nonflammable)	Has the resilience of natural rubber with better resistance to oil, gasoline, ozone, weather and heat. Excellent memory for temperature cycling applications - good electrical resistivity - reusable in most cases.
Viton®	-10° F to +450° F (-20° C to +232° C)	Fluoroelastomer	Retains mechanical properties at high temperature. Resistant to oils, solvents, fuels, corrosive industrial chemicals. Good electrical properties - reusable in most cases.
Teflon®	-300° F to +450° F (-185° C to +232° C)	Tetrafluoroethylene Plastic (Thermoplastic Resin) (nonflammable)	Least permeable to gases. Has natural lubricity - resists adhesion of foreign matter - reusable in most cases.
Lava	-300° F to +1600° F (-185° C to +870° C)	Natural Magnesium Silicate	Low thermal coefficient. Crushes to powdered mass under compression - slightly porous to light gases and steam. NOT RECOMMENDED FOR HIGH VACUUM. Not reusable.
Grafoil®	-400° F to +925° F (-240° C to +495° C) +3000° F (+1650° C) in reducing atmosphere	Graphite in foil layers (conductive)	Low vapor pressure, low gas permeability - excellent for vacuum applications. Good for thermal cycling applications. Natural lubricity, electrically conductive. Superior sealing capabilities at +925° F (+496° C). Not reusable in most cases.

Conax Technologies offers numerous combinations of pipe nipples, hex nipples, unions and couplings to be used to mount your assembly to a vessel. These may also be used in combination with spring-loaded mounting devices. All pipe nipples and unions are 1/2 NPT stainless steel unless otherwise specified. Carbon steel is also available. Conax does not recommend the use of nipple combinations (N, NU, NUN or HN) without additional probe support.

Standard Lengths

Catalog Designation	Length*	
	IN	MM
U	2.00	50.8
C	2.00	50.8
HC	1.56	39.6
N	4.00	101.6
HN	2.00	50.8
RSN, NRSN	4.00	101.6
W4, W8, NW4, NW8	2.00	50.8
SLN	4.00	101.6
SLAN(S)	2.00	50.8
CSLW	2.00	50.8
CSLP	1.00	25.4

* Reference dimension

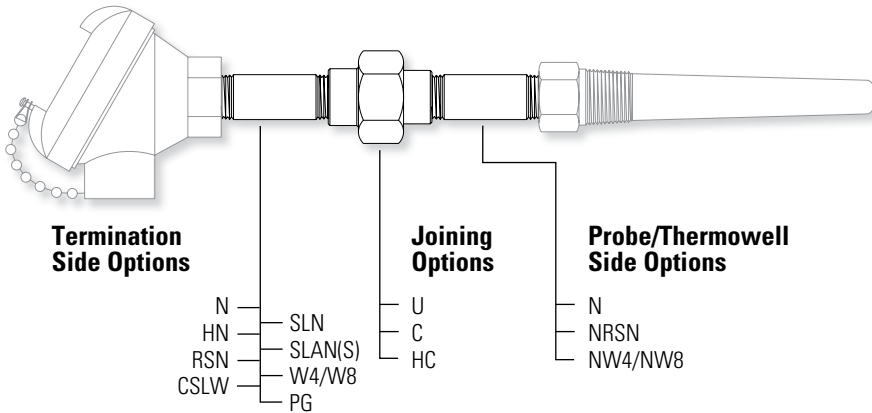

Calculating the Length of Nipple Combinations

For assemblies using pipe nipples, the active length is the distance from the sensor end of the probe to the end of the pipe nipple.

The length of the pipe nipple must also be specified in an order, keeping in mind that when engaging 1/2 NPT threads, approximately 1/2" is lost per connection.

If a spring-loaded pipe nipple (SLN) is ordered, the active length is measured with the spring uncompressed.

Conax recommends 1/4" of spring compression when the probe is installed.

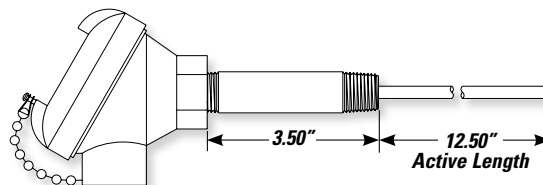

Example 1: *RTD43W3-SS25-T5AL(RSN3.50)-12.50"*

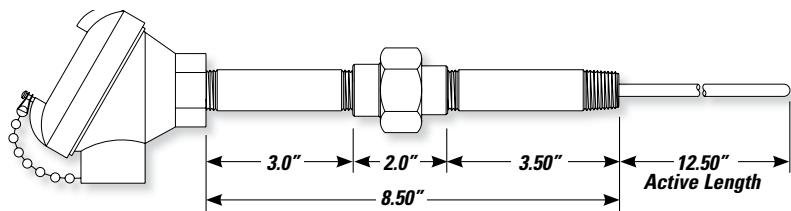

Example 2: *RTD43W3-SS25-T5AL(SLNUN8.50)-12.50"*

Note: Stainless steel is the standard material. For items where a carbon steel option is available, this is designated by adding "CS" after the mounting component length.

Stainless Steel Example:
RTD43W3-SS25-T5AL(RSN3.50)-12.50"

Carbon Steel Example:
RTD43W3-SS25-T5AL(RSN3.50CS)-12.50"

Catalog Designations



N – Pipe Nipple

Conax pipe nipples consist of Schedule 40 pipe with male threads on each end, 4 inch long stainless steel standard. Carbon steel (CS) and longer lengths are available options. Pipe nipples feature a 1/2 NPT and nominal bore ID of 0.62". Pipe nipples are used to provide temperature standoff between the pipe/vessel and terminal head. They are also often used as a spacer between insulated vessels/pipes and terminal heads.

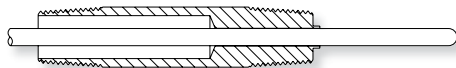

RSN – Rigidly Sealed Nipple

The Conax rigidly sealed nipple is similar in usage to a pipe nipple, but is weld sealed on the process end to provide pressure/vacuum sealing against liquid or gases reaching the terminal head. The RSN is sized to fit the requested sensor diameter. Available in stainless steel only, 1/2 NPT, 4" long standard. Other lengths are available.

NRSN

This version of the RSN is not weld sealed on the process end. It provides a pilot for the probe without the seal.

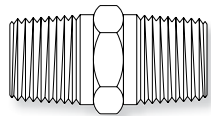

HN – Hex Nipple

The hex nipple provides a shorter temperature standoff than the pipe nipple and includes wrench flats. The HN features a 2" long fixed overall length and is available in stainless steel only.

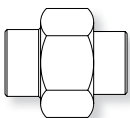

U – Union

This Class 150 lb., 1/2 NPT standard union allows disassembly, removal and positioning of the sensor assembly. Stainless steel is standard. Carbon steel (CS) is also available.



C – Coupling

A Class 150 lb. standard coupling may be used to join pipe nipple sections. Stainless steel is standard. Carbon steel (CS) is also available.

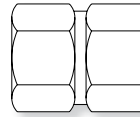

HC – Hex Coupling

The hex coupling offers wrench flats. Available in stainless steel only.

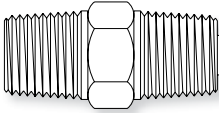

W Mounting

The Conax W fitting is a stainless steel fitting with male threads on both ends. The bore is sized to pass standard probe diameters of 0.125", 0.187" or 0.250". NW4 and NW8 fittings are not welded and can be used to pilot the probe for insertion into tubewells or thermowells. W4 and W8 fittings are weld sealed to form a rugged leak-tight mounting. Order W8 for a 1/2 NPT, W4 for a 1/4 NPT.

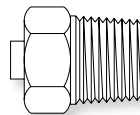

W7

The Conax W7 fitting is a stainless steel fitting with male threads on one end only. The hex end is welded to the sheath to form a fixed mounting and liquid/gas seal. The bore is sized to pass standard probe diameters of 0.125", 0.187" or 0.250". When included in an assembly, both the active and immersion lengths must be specified.

Conax provides several types of spring-loaded assemblies to meet your application needs. All are designed to provide positive contact of the sensor tip with the surface to be measured.

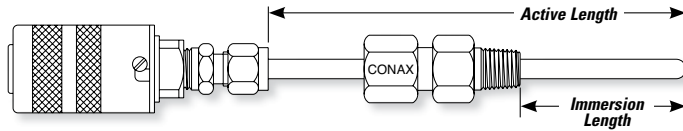

When ordering spring loads, the immersion length should be measured with the spring uncompressed. We recommend 1/4" of spring compression when the probe is installed.

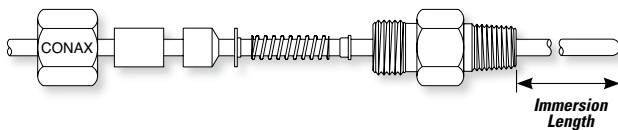

Spring Load Assembly (SL)

The SL assembly features rugged stainless steel construction with a Teflon sealant.

- Temperature Range: -190° F to +450° F (-123° C to +232° C)
- Spring Pressure: approximately 2 to 8 pounds
- Spring Travel: .250" to .375" (6.35-9.52mm)
- Available with Type B cap for direct mount

A typical catalog number for a spring load assembly is:

J-SS12-U-B2-SL-12.50", A=3.50"

Spring Loaded Assembly Specifications

Catalog Type	Probe Diameter		Mounting Thread NPT IN	Nominal Mounting Thread Engagement		Length with A Cap	
	IN	MM		IN	MM	IN	MM
SL6	.062	1.57	1/8	1/4	6.35	1.18	30.0
SL12	.125	3.18	1/8	1/4	6.35	1.18	30.0
SL18	.187	4.75	1/4	3/8	9.52	2.00	50.8
SL25	.250	6.35	1/2	1/2	12.70	2.50	63.5

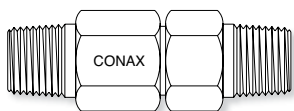

SL assembly shown with B cap.

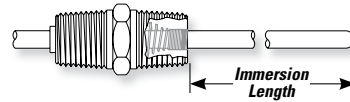

Crimp Spring Load (CSLW)

This assembly provides a spring load with male 1/2 NPT threads at both ends. Wrench flats permit easy tightening, removal and reuse. Constructed of sturdy stainless steel with an overall length of 2" (50.8mm). Bores are sized to fit the diameter of the probe.

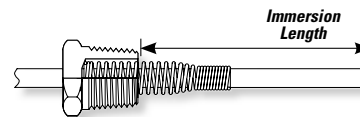

Crimp Spring Plug (CSLP)

This assembly includes threads on the mounting end only. It is designed for use with T3/T4, and Plug & Jack assemblies to provide positive contact with a pipewell bottom or other vessel surfaces.

Example: J-SS12-U-T3-CSLP-12.50", A=3.50"

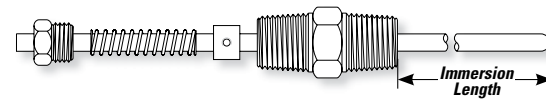

Spring Load Adjustable Nipple (SLAN and SLANS)

The SLAN is an adjustable spring-loaded sensor fitting. The set-screw collar allows the fitting to be fully adjustable and "forgiving" to accommodate errors in thermowell and sensor lengths.

- 1/2 NPT on both ends
- Available for 0.125" (3.18mm), 0.187" (4.75mm) and 0.250" (6.35mm) diameters
- Stainless steel construction
- 2.75" (57.15mm) overall length

The SLANS assembly includes a Viton O-ring.

- 50 psi maximum
- 1/2 NPT on both ends
- Available for 0.250" (6.35mm) diameter only
- Stainless steel construction
- 2-1/4" (57.15mm) overall length

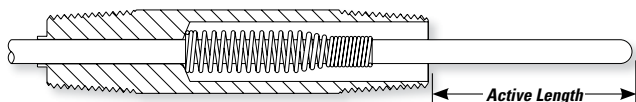

Spring Load Nipple Assembly (SLN)

The SLN assembly provides a spring load inside a pipe nipple. It is available for 0.125" (3.18mm), 0.187" (4.75mm) and 0.250" (6.35mm) diameter probes. A union and additional nipple may also be added to form SLNU and SLNUN configurations.

- 4" overall length; other lengths available
- 1/2 NPT on both ends
- Stainless steel construction. Carbon steel optional

T11SL

- Includes spring loaded assembly built into the head
- Allows complete disassembly and removal of the sensor probe without dismantling the terminal head from the conduit or vessel
- Weathertight
- Lightweight cast aluminum construction
- Silver-painted finish designed to resist weak acids, organic solvents, alkalis, sunlight and dust
- Screw cover with chain leash and O-ring seal
- 6 terminal posts
- Service temperature upper limit: 275° F (135° C)
- Use of NW8 or N fitting recommended for mounting to probe
- Size (reference): 3.25" OD x 3.7" L, 0.7 lb.
- Conduit port 1/2 NPT



Replacement Probe with Type W8 or W4 Fitting Assemblies

Replacement probe fitting assemblies are available for those who wish to replace the probe without replacing the terminal head. Order W8 for a 1/2 NPT, W4 for a 1/4 NPT. To order, both the immersion length and the active length must be specified, as demonstrated in the following examples:

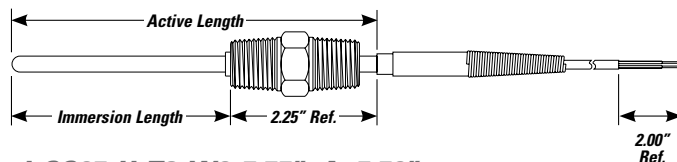

J-SS25-U-T3-W8-7.75", A=5.50"

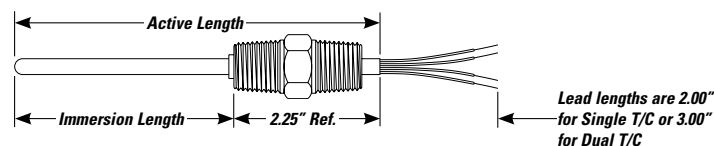

J-SS25-U-T1(2")-W8-7.75", A=5.50"

Product Identification Methods



Aluminum Foil Tag – All Conax sensor assemblies include an aluminum foil tag that identifies the catalog description for that assembly.

Stainless Steel Tag – Laser-etched stainless steel identification tags can be supplied. Consult factory for details.



Conax offers an assortment of termination styles and terminal heads for multiple environment and application uses. In this section, the maximum service temperature cited applies to the terminal head without the thermocouple sensor. Thermocouple sensor cold end sealant maximum temperature is 300° F (150° C). Higher temperature cold end seals are available (consult factory). Specified dimensions are nominal values and do not include the length of compression seals.



Stripped Teflon Sleeved Leadwires (T1)

This most basic termination is available on all Conax probes.

- Probe end is impregnated with moisture-resistant compound to prevent liquid or gas penetration.
- Standard leads are 1" long on all but the 0.040" diameter, which uses 5/8" leads. Longer leads are available. Specify in inches, e.g. T1(3").
- Leads are solid wire color-coded Teflon sleeved.
- Maximum service temperature: 300° F (150° C)

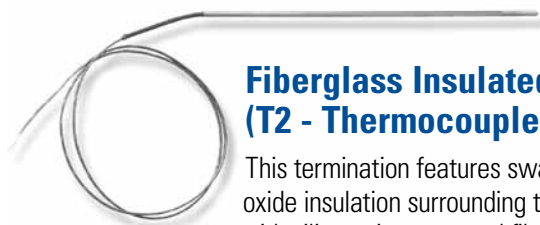

Fiberglass Insulated Leadwires (T2 - Thermocouple)

This termination features swaged magnesium oxide insulation surrounding the elements, with silicone-impregnated fiberglass leadwire insulation swaged approximately 3/4" into the sheath.

- The fiberglass insulation protects the integral leadwires under mildly adverse atmospheric conditions (not recommended where excessive vibration and abrasion are encountered).
- Standard cold end lead length is 24". Longer leads are available on request. Specify in feet, e.g. T2(3FT).
- Available with the following sheath sizes: 0.062" (AWG 30 leadwire), 0.125" (AWG 24 leadwire), and 0.187" (AWG 20 leadwire). Maximum sheath length is 5 ft.
- Service temperature upper limit: 700° F (370° C)

Teflon Insulated Leadwire (T2 - RTD)

This termination features aluminum oxide powder insulation surrounding the element and Teflon-insulated leadwires, all capped with potting compound to prevent moisture penetration.

- The Teflon insulation protects the integral leadwires under mildly adverse atmospheric conditions.
- Unit is to be used straight. Bending is not recommended.
- Standard cold end lead length is 24". Longer leads are available on request. Specify in feet, e.g. T2(3FT).
- Standard probe diameter is 0.250".
- Service temperature upper limit: 300° F (150° C)



Terminal Barrel with Leadwire (T3 - Thermocouple)

This exclusive Conax design provides a practically unbreakable connection between the leadwire and the probe lead.

- Silicone impregnated fiberglass braid insulation
- Leadwires are joined in the adaptor housing, secured by a special strain harness for diameters of 0.187" or smaller, and encapsulated in potting compound to prevent moisture penetration.
- Spring dampens and reduces vibration and abrasion.
- Standard cold end lead length is 24". Longer leads are available on request. Specify in feet, e.g. T3(3FT).
- Service temperature upper limit: 300° F (150° C).
- Leads sizes: AWG 20 for sheath sizes 0.125" to 0.375"; AWG 24 for 0.040" and 0.062" sheath diameters.
- The terminal barrel is larger than the sheath, crimped to the sheath and filled with potting compound to prevent moisture penetration. Barrel diameter sizes: 0.040" to 0.187" sheath diameter – 0.312", 0.250" sheath diameter – 0.375", 0.375" sheath diameter – 0.500".
- T3(HT) high temperature model uses high temperature insulation compound to achieve service temperature upper limit of 900° F (480° C).

Terminal Barrel with Leadwire (T3 - RTD)

This exclusive Conax design provides a practically unbreakable connection between the leadwire and the probe lead.

- Standard leadwires are 24 AWG stranded silver-plated copper, Teflon-insulated wire with Teflon overall.
- Leadwires are joined in the adaptor housing, secured by a special strain harness for diameters of 0.187" or smaller, and encapsulated in potting compound to prevent moisture penetration.
- Spring dampens and reduces vibration and abrasion.
- Standard cold end lead length is 24". Longer leads are available on request. Specify in feet, e.g. T3(3FT).
- Service temperature upper limit: 300° F (150° C).
- The terminal barrel is larger than the sheath, crimped to the sheath and filled with potting compound to prevent moisture penetration. Barrel diameter sizes: up to 4-wire probes – 0.375", 6- and 8-wire probes – 0.500".



Terminal Barrel with Leadwire (T4 - Thermocouple)

This modification of the T3 termination provides a stainless steel overbraid for maximum flexibility and abrasion resistance. The overbraid is embedded in the potting compound to ensure mechanical strength.

- Standard cold end lead length is 24". Longer leads are available on request. Specify in feet, e.g. T4(3FT).
- Leads sizes: AWG 20 for sheath sizes 0.125" to 0.375"; AWG 24 for 0.040" and 0.062" sheath diameters.
- The terminal barrel is larger than the sheath, crimped to the sheath and filled with potting compound to prevent moisture penetration. Barrel diameter sizes: 0.040" to 0.187" sheath diameter – 0.312", 0.250" sheath diameter – 0.375", 0.375" sheath diameter – 0.500".
- T4(HT) high temperature model uses high temperature insulation compound to achieve service temperature upper limit of 900° F (480° C).

Terminal Barrel with Leadwire (T4 - RTD)

This modification of the T3 termination provides a stainless steel overbraid for maximum flexibility and abrasion resistance. The overbraid is embedded in the potting compound to ensure mechanical strength.

- Standard leadwires are 24 AWG stranded silver-plated copper, Teflon-insulated wire with Teflon overall.
- All probes with 4 wires or less include a spring to dampen vibration and reduce abrasion of the leadwire.
- Standard cold end lead length is 24". Longer leads are available on request. Specify in feet, e.g. T4(3FT).
- The terminal barrel is larger than the sheath, crimped to the sheath and filled with potting compound to prevent moisture penetration. Barrel diameter sizes: up to 4-wire probes – 0.375", 6- and 8-wire probes – 0.500".
- T4(HT) high temperature model uses fiberglass braid insulated wire and high temperature insulation compound to achieve service temperature upper limit of 900° F (480° C).

Screw Cover Enclosure (T5CI)

- NEMA 4 rated
- Cast iron construction with durable gray paint applied to prevent rust
- Screw cover with chain leash and silicone gasket seal
- Service temperature upper limit: 300° F (150° C) with gasket
- 6 terminal posts
- Brass metal-to-metal compression fitting supplied when head is ordered with sensor probe
- Accepts "hockey puck" style transmitter
- Size (reference): 3.38" OD x 3.6" L, 1.8 lb.
- Conduit port 3/4 NPT



Screw Cover Enclosure (T5AL)

- NEMA 4 rated
- Lightweight cast polished aluminum construction
- Screw cover with chain leash and silicone gasket seal
- Service temperature upper limit: 300° F (150° C) with gasket
- 6 terminal posts
- Brass metal-to-metal compression fitting supplied when head is ordered with sensor probe
- Accepts "hockey puck" style transmitter
- Size (reference): 3.3" OD x 3.6" L, 0.7 lb.
- Conduit port 3/4 NPT



Screw Cover Enclosure (T5SS)

- NEMA 4X rated
- 316L stainless steel construction
- Screw cover with chain leash and silicone gasket seal
- Service temperature upper limit: 300° F (150° C) with gasket
- 6 terminal posts
- Conax PG Series stainless steel sealing gland with lava sealant supplied when head is ordered with sensor probe
- Accepts "hockey puck" style transmitter
- Size (reference): 3.1" OD x 3.6" L, 1.7 lb.
- Conduit port 3/4 NPT



Conduit Box (T7)

- Weathertight
- Aluminum conduit box with gasket seal
- Accommodates up to 8 terminals standard, 16 terminals optional
- Provides easy access to terminals
- Ideal for multiple probe or extra long thermocouple/RTD assemblies
- Optional PG series fitting available for use with single probes; MHM series fitting available for use with multiple probes
- Service temperature upper limit: 300° F (150° C)
- Size (reference): 4.75" W x 6.5" L x 2.25" H, 1.35 lb.
- Conduit port 3/4 NPT

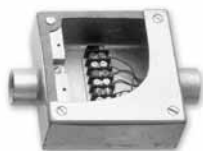

Screw Cover Enclosure (T8E)

- Explosion proof - meets Class 1, Groups B, C and D; Class II, Groups E, F, G; and Class III requirements
- Gray iron body with aluminum screw cover
- O-ring sealed
- Service temperature upper limit: 300° F (150° C)
- Accepts up to 8 leads
- Brass metal-to-metal compression fitting supplied when head is ordered with sensor probe
- Size (reference): 3.75" OD x 4.6" L, 2.3 lb.
- Conduit port 1/2 NPT



Screw Cover Enclosure (T11SL)

- Includes spring loaded assembly built into the head
- Allows complete disassembly and removal of the sensor probe without dismantling the terminal head from the conduit or vessel
- Weathertight
- Lightweight cast aluminum construction
- Silver-painted finish designed to resist weak acids, organic solvents, alkalis, sunlight and dust
- Screw cover with chain leash and O-ring seal
- 6 terminal posts
- Service temperature upper limit: 275° F (135° C)
- Use of NW or N fitting recommended for mounting to probe
- Size (reference): 3.25" OD x 3.7" L, 0.7 lb.
- Conduit port 1/2 NPT



Screw Cover Enclosure (T11)

- Weathertight
- Lightweight cast aluminum construction
- Silver-painted finish designed to resist weak acids, organic solvents, alkalis, sunlight and dust
- Screw cover with chain leash and O-ring seal
- 6 terminal posts
- Accepts "hockey puck" style transmitter
- Service temperature upper limit: 275° F (135° C)
- Brass metal-to-metal compression fitting supplied when head is ordered with sensor probe
- Size (reference): 3.25" OD x 3.7" L, 0.7 lb.
- Conduit port 1/2 NPT



Flip Top Hinged Enclosure (T12)

- Weathertight
- Easy-open globe head with camlock
- Lightweight aluminum construction
- O-ring sealed
- Accepts up to 6 leads
- Accepts "hockey puck" style transmitter
- Service temperature upper limit: 300° F (150° C)
- Brass metal-to-metal compression fitting supplied when head is ordered with sensor probe
- Size (reference): 3.3" OD x 4.3" L, 0.6 lb.
- Conduit port 1/2 NPT



Screw Cover Enclosure (T11PL)

- Weathertight
- Lightweight plastic construction
- Corrosion resistant
- Screw cover with chain leash and O-ring seal
- 6 terminal posts
- Accepts "hockey puck" style transmitter
- Service temperature upper limit: 275° F (135° C)
- Brass metal-to-metal compression fitting supplied when head is ordered with sensor probe
- Size (reference): 3.25" OD x 3.8" L, 0.5 lb.
- Conduit port 1/2 NPSM



Screw Cover Enclosure (T13)

- FDA compliant, NEMA 4 rated
- Ideal for sanitary, corrosive or general purpose pharmaceutical and food applications
- White unpigmented polypropylene construction with stainless steel chain/pin
- Ethylene propylene gasket
- Good resistance to most acid solutions, alkalines and salt water
- 6 terminals
- Service temperature upper limit: 198° F (92° C)
- Conax PG Series stainless steel sealing gland with Teflon sealant supplied when head is ordered with sensor probe
- Size (reference): 3.0" OD x 3.3" L, 0.2 lb.
- Conduit port 3/4 NPT



Screw Cover Enclosure (T15EAL)

- FM and CSA approved for hazardous environments with an Explosion-Proof rating for Class I, Division 1, Groups B, C and D, and Dust Proof/Ignition Proof Rating for Class II, Division 1, Groups E, F and G
- NEMA 4 rated when configured with a nitrile O-ring configuration (standard); the service temperature upper limit is: 300° F (150° C)
- Aluminum construction
- 6 terminal posts
- Accepts "hockey-puck" style transmitter
- Brass metal-to-metal compression fitting supplied when head is ordered with sensor probe
- Size (reference): 3.6" OD x 4.0" L, 1 lb.
- Conduit port 3/4 NPT



Flip Top Hinged Enclosure (T13F)

- FDA compliant, NEMA 4 rated
- Ideal for sanitary, corrosive or general purpose pharmaceutical and food applications
- Easy open flip top
- White unpigmented polypropylene construction with stainless steel chain/pin
- Epichlorohydrin gasket
- Good resistance to most acid solutions, alkalines and salt water
- Accepts up to 6 leads
- Service temperature upper limit: 198° F (92° C)
- Conax PG Series stainless steel sealing gland with Teflon sealant supplied when head is ordered with sensor probe
- Size (reference): 3.2" OD x 3.4" L, 0.2 lb.
- Conduit port 3/4 NPT



Screw Cover Enclosure (T15ESS)

- FM and CSA approved for hazardous environments with an Explosion-Proof rating for Class I, Division 1, Groups B, C and D, and Dust Proof/Ignition Proof Rating for Class II, Division 1, Groups E, F and G
- NEMA 4X rated when configured with a nitrile O-ring configuration (standard); the service temperature upper limit is: 300° F (150° C)
- Stainless steel construction
- 6 terminal posts
- Accepts "hockey-puck" style transmitter
- Conax PG Series stainless steel sealing gland with lava sealant supplied when head is ordered with sensor probe
- Size (reference): 3.6" OD x 4.0" L, 1.9 lb.
- Conduit port 3/4 NPT



Screw Cover Enclosure (T13T)

- FDA compliant, NEMA 4X rated
- Ideal for sanitary, corrosive or general purpose pharmaceutical and food applications
- White unpigmented polypropylene construction with stainless steel chain/pin
- Screw cover with epichlorohydrin gasket
- Good resistance to most acid solutions, alkalines and salt water
- 4 terminal posts
- Accepts "hockey-puck" style transmitter
- Service temperature upper limit: 198° F (92° C)
- Size (reference): 2.8" OD x 3.2" L, 0.2 lb.
- Conduit port 3/4 NPT



Screw Cover Enclosure (T15EAL(ATEX))

- FM and CSA approved for hazardous environments with an explosion-proof rating for Class 1 Group A, B, C, D, and Dust-Proof, Ignition-Proof Rating for Class II, Groups E, F, G.
- NEMA 4X Rated
- Aluminum construction; Epoxy Polyurethane Coated
- 6 Terminal Posts
- Accepts "hockey-puck" style transmitters
- Conax PG Series stainless steel sealing gland with Teflon sealant when head is ordered with sensor probe
- Size reference: 3.5"OD x 4.50"L
- Conduit Part 3/4 NPT



Compact Connection Head (B Series)



- Compact, lightweight head for convenient hookup of customer extension wire
- Nickel-plated for corrosion resistance
- Zinc-plated brass terminal posts secured on a ceramic terminal block
- Accepts up to 14 AWG wire
- Easy removal and access – loosen two screws and turn cover slightly
- Service temperature upper limit: 300° F (150° C)
- Size (reference): 1.2" OD x 2.4" L, 0.2 lb.
- Grommet hole diameter: 0.234" (reference)
- B2 accepts two leadwires
- B3 accepts three leadwires
- B4 accepts four leadwires
- Mounting port 1/4 NPT (standard), 1/8 NPT (optional)

Specialty Connection Head (C Series)



- Provides a convenient and compact method to terminate one or more sensors contained within a single probe
- Stainless steel screw posts mounted in high purity alumina securely fasten leadwires in position
- Black anodized aluminum cover, stainless steel body
- 0.250" diameter probe only
- Available as C2 (two-wire), C3 (three-wire), C4 (four-wire), C6 (six-wire) or C8 (eight-wire). Terminal posts are provided for indicated number of wires only
- Service temperature upper limit: 200° F (93° C) with grommet, 700° F (371° C) with grommet removed

Quick Disconnect



- Water and vapor resistant when assembled tight
- Polarized plug and socket design prevents crossing of leads
- Easy to assemble and disassemble
- Plugs and sockets made of thermocouple material maintain continuity between thermocouple elements and leadwires
- Aluminum body and cap construction
- Available for sheath diameters 0.062" to 0.250"
- Size (reference): 0.8" OD x 2.9" L, 0.1 lb.
- Service temperature upper limit: 200° F (93° C) for QD; 450° F (232° C) for QDHT (high temperature model)

Open Style Terminal Head (MD Series)



- Bodies are molded of high performance thermoset compounds, color-coded by type
- Heads are mounted directly to the sheath using a brass metal-to-metal compression fitting
- Service temperature upper limit: 400° F (205° C)
- High temperature models are also available. Service temperature upper limit: 800° F (425° C)
- Available with 0.062", 0.125", 0.187" or 0.250" diameter sheath
- MD2 and MD2HT accepts two leadwires; size (reference): 1" OD x 1.1" long, 0.07 lb.
- MD3 and MD3HT accepts three leadwires; size (reference): 1.25" OD x 1.1" long, 0.07 lb.
- MD4 and MD4HT accepts four leadwires; size (reference): 1.25" OD x 1.1" long, 0.07 lb.

Plug & Jack

Polarized plug and jack assemblies are made from molded glass-filled thermoset compounds with contacts made of thermocouple alloy or copper.



- Pins are polarized and identification marks are molded into the connector bodies
- Connectors are color-coded according to type
- Standard and miniature sizes available
- Metal ferrule tube adapters secure the probe in place, and cable clamps are used to hold the wire and provide strain relief
- Maximum service temperature is 400° F (204° C)
- High Temperature connectors are available for temperatures to 800° F (427° C)
- Dual construction available for thermocouple models only. Dual polarized plug and jack assemblies offer the same features as standard plug and jack assemblies but are supplied with a dual tube adapter. Service temperature upper limit: 400° F (204° C)
- Size (reference): Standard PJFC (single) – 3.8" L x 0.6" H, 0.163 lb; Miniature PJFC – 1.75" L x 0.3" H, 0.042 lb.

* Standard size connectors have round pins

* Mini size connectors have flat pins

Standards

NEMA 4

NEMA 4 heads meet requirements providing protection against windblown dust and rain, splashing water, hose-directed water, and external ice formation.

T5CI – Cast Iron

T5AL – Aluminum

T8E – Aluminum/Malleable Iron

T13 – Plastic

T15EAL – Aluminum

NEMA 4X

NEMA 4X heads meet NEMA 4 requirements and provide an added degree of corrosion resistance.

T5SS – Stainless Steel

T13F – Plastic

T13T – Plastic

T15ESS – Stainless Steel

FDA-Compliant

FDA-compliant heads meet standards for sanitary applications.

T13 – Plastic Screw Cover

T13F – Plastic Flip Top

T13T – Plastic Screw Cover

FM & CSA Approved for Hazardous Environments

T15EAL – Aluminum

T15ESS – Stainless Steel

T15EAL(ATEX) – Aluminum

Weathertight

Weathertight heads provide general protection against outdoor environmental challenges.

T7 – Aluminum

T11 – Aluminum

T11PL – Plastic

T12 – Aluminum

B – Plated Steel

P4 – Plastic

Materials of Construction

Aluminum

T5AL – Screw cover, NEMA 4

T7 – Weathertight, conduit box

T11 – Screw cover, weathertight

T12 – Weathertight, flip top

T15EAL – Screw cover, FM & CSA Approved for Explosion-Proof Environments

T15EAL(ATEX) – Screw Cover, ATEX

Cast Iron

T5CI – Screw cover, NEMA 4

Stainless Steel

T5SS – Screw cover, NEMA 4X

T15ESS – Screw cover, FM & CSA Approved for Explosion-Proof Environments

Combination Metals

T8E – Aluminum & Malleable Iron

B – Plated Steel

Plastic

T13 – Screw cover, FDA-white

T13F – Flip top, FDA-white

T13T – Screw cover, FDA-white

P4 – Screw cover, weathertight

T11PL – Screw cover, weathertight

Transmitters provide a convenient and economical way to send a signal from a sensor to a datalogger, controller or the control room of a processing plant. The transmitter converts the sensor's small voltage signal into a current output signal that runs on copper electrical wires. This method is more economical than running long lengths of multi-conductor shielded cables for RTDs or specially compensated, shielded extension-grade wire for thermocouples. In addition, the output is less subject to distortion/interference from external electrical noise, RFI and EMI.

Conax Technologies offers a variety of temperature transmitters to meet customer application requirements and configurations. For more information on any individual type of transmitter, request our data sheet on that type or visit www.conaxtechnologies.com

Hockey puck style transmitters fit in Conax T5, T11, T12, T13T and T15 termination heads.

2-Wire Programmable Head Mount, RTD Transmitter – Model 5333A

- RTD or Ohm Input
- High Measurement Accuracy
- 3-Wire Connection
- Programmable Sensor Error Value

Application:

- Linearized temperature measurement with Pt100...Pt1000 or Ni100...Ni1000 sensor.
- Conversion of linear resistance variation to a standard analog current signal.

Technical Characteristics:

- Programmable within seconds to measure temperatures within all standard sensor ranges.
- The RTD and resistance inputs have cable compensation for 3-wire connections.

Mounting / Installation:

- DIN Form B sensor head compatible.
- Supplied with 2 x M4 screws on a 33 mm (1.3") bolt circle (optional 6-32 screws available).



2-Wire Programmable Head Mount, TC Transmitter – Model 5334A

- TC or mV Input
- Extremely High Measurement Accuracy
- 1.5 kVAC Galvanic Isolation
- Programmable Sensor Error Value

Application:

- Linearized temperature measurement for TC sensor.
- Amplification of bipolar mV signals to a 4...20 mA signal, optionally

Technical Characteristics:

- Programmable within seconds to measure temperatures within all standard TC ranges.
- Cold junction compensation (CJC) with a built-in temperature sensor.
- Continuous check of vital stored data

Mounting / Installation:

- DIN Form B sensor head compatible.
- Supplied with 2 x M4 screws on a 33 mm (1.3") bolt circle (optional 6-32 screws available).



2-Wire Transmitter with HART® Protocol Head Mount Universal – Model 5335A

- RTD, TC, Ohm or mV Input
- Extremely High Measurement Accuracy
- 1.5 kVAC Galvanic Isolation
- Programmable Sensor Error Value

Application:

- Linearized temperature measurement with Pt100...Pt1000, Ni100...Ni1000, or TC sensor.
- Conversion of linear resistance variation to a standard analog current signal
- Amplification of a bipolar mV signal to a standard 4...20 mA current signal

Technical Characteristics:

- Programmable within seconds to measure temperatures within all standard ranges.
- The RTD and resistance inputs have cable compensation for 2-, 3- and 4-wire connection
- Continuous check of vital stored data.

Mounting / Installation:

- DIN Form B sensor head compatible.
- Supplied with 2 x M4 screws on 33mm (1.3") bolt circle (optional 6-32 screws available).



2-Wire Transmitter with HART® Protocol Head Mount Universal (ATEX, CSA/FM) – Model 5335D

- RTD, TC, Ohm or mV Input
- Extremely High Measurement Accuracy
- HART® Communication
- 1.5 kVAC Galvanic Isolation
- Complies with European ATEX and CSA/FM Requirements

Application:

- Linearized temperature measurement with Pt100...Pt1000, Ni100...Ni1000, or TC sensor.
- Difference or average temperature measurement of 2 sensor inputs.
- Conversion of linear resistance variation to a standard analog current signal
- Amplification of a bipolar mV signal to a standard 4...20 mA current signal
- Connection of up to 15 transmitters to a digital 2-wire signal with HART® communication.

Technical Characteristics:

- Programmable within seconds to measure temperatures within all standard ranges.
- The RTD and resistance inputs have cable compensation for 2-, 3- and 4-wire connection
- Continuous check of vital stored data.
- Sensor error detection according to the guidelines in NAMUR NE 89.

Mounting / Installation:

- DIN Form B sensor head compatible.
- Supplied with 2 x M4 screws on 33mm (1.3") bolt circle (optional 6-32 screws available).



2-Wire Programmable Transmitter Din Rail RTD Model 6333A

- RTD or Ohm Input
- High Measurement Accuracy
- 3-Wire Connection
- Programmable Sensor Error Value
- 1- or 2-Channel Version

Application:

- Linearized temperature measurement with PT100...PT1000 or Ni100...Ni1000 sensor.
- Conversion of linear resistance variation to a standard analog current signal.

Technical Characteristics:

- Programmable within seconds to measure temperatures within all standard sensor ranges.
- The RTD and resistance inputs have cable compensation for 3-wire connections
- A limit can be programmed on the output signal.

Mounting / Installation:

- Mounted vertically or horizontally on a DIN rail. Using the 2-channel version up to 84 channels per meter can be mounted



2-Wire Programmable Transmitter Din Rail T/C Model 6334A

- TC or mV Input
- Extremely High Measurement Accuracy
- 1.5 kVAC Galvanic Isolation
- Programmable Sensor Error Value
- 1- or 2-Channel Version

Application:

- Linearized temperature measurement with TC sensor.
- Amplification of bipolar mV signals to a 4...20 mA signal, optionally linearized according to a defined linearization function.

Technical Characteristics:

- Within seconds the user can program a 6334A to measure temperatures within all standard TC ranges.
- Cold junction compensation (CJC) via a built in temperature sensor.
- A limit can be programmed on the output signal.
- Continuous check of vital stored data.

Mounting / Installation:

- Mounted vertically or horizontally on a DIN rail. Using the 2-channel version up to 84 channels per meter can be mounted



2-Wire Programmable Transmitter Din Rail Universal Model 6331A

- RTD, TC, Ohm or mV Input
- Extremely High Measurement Accuracy
- 1.5 kVAC Galvanic Isolation
- Programmable Sensor Error Value
- 1- or 2-Channel Version

Application:

- Linearized temperature measurement with Pt100...Pt1000 or Ni100...Ni1000 or TC sensor.
- Conversion of Linear resistance variation to a standard analog current signal.
- Amplification of bipolar mV signals to a 4...20 mA signal.

Technical Characteristics:

- Within seconds the user can program a 6331A to measure temperatures within all standard ranges.
- The RTD and resistance inputs have cable compensation for 2-, 3-, and 4-wire connection.
- A limit can be programmed on the output signal.
- Continuous check of vital stored data.

Mounting / Installation:

- Mounted vertically or horizontally on a DIN rail. Using the 2-channel version, up to 84 channels per meter can be mounted



Programmable LED Indicator, 2 Relay, Front Key Programmable Model 5714

- 4-Digit, 14-Segment LED Indicator
- Input for RTD, TC, mA, V, and Potentiometer
- Universal Supply Voltage
- Front Key Programmable
- Available with Optional 2 Relays and Analog Output

Application:

- Display for digital readout of temperature, current, voltage or 3-wire potentiometer signals.
- Process control with 2 potential-free relays and / or analog output.

Technical Characteristics:

- 4-digit LED indicator with 13.8 mm 14-segment characters. Max. display readout -1999...9999 with programmable decimal point, relay ON/OFF indication.

Technical Characteristics (cont.):

- Operational parameters can be adjusted via the front panel keypad
- Help text in eight languages can be selected via front panel keypad
- Preview 5714 is available fully-configured from the factory or can be field programmed
- In versions with relay outputs the user can minimize the installation test time by activating/deactivating each relay independently of the input signal.

Mounting / Installation:

- Front Panel Mount.
- Rubber Gasket (mounted between panel cutout hole and display front panel provides IP65 (NEMA4) rating
- Optional splash proof cover available for additional protection in extremely wet environments.



Programmable LED Indicator, 4 Relay, Front Key and PC Programmable Model 5715

- 4-Digit, 14-Segment LED Indicator
- Input for RTD, TC, mA, V, and Potentiometer
- 4 Relays with Optional Analog Output
- Universal Supply Voltage
- Programmable via Front Keypad or PC

Application:

- Display for digital readout of temperature, current, voltage or 3-wire potentiometer signals.
- Process control with 4 pairs of potential-free change-over relays and analog output.

Technical Characteristics:

- 4-digit LED indicator with 13.8 mm 14-segment characters. Max. display readout -1999...9999 with programmable decimal point, relay ON/OFF indication.

Technical Characteristics (cont.):

- Standard operational parameters can be adjusted via the front panel keypad or by way of a PC and the configuration program preset. Additional configuration options are available through PReset, such as customer defined linearization for special input signals
- Help text in eight languages selected via front panel keypad.
- A menu item allows the user to minimize the installation test time for the relay outputs by activating / deactivating each relay independently of the input signal.

Mounting / Installation:

- Front Panel Mount.
- Rubber Gasket (mounted between panel cutout hole and display front panel provides IP65 (NEMA4) rating
- Optional splash proof cover available for additional protection in extremely wet environments.



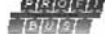

Transmitter Selection Guide

Conax Technologies offers a wide range of temperature transmitters to meet your exact needs. In addition, we offer a 5 year guarantee on all of the transmitter products listed. Detailed product data sheets are available on our website at www.conaxtechnologies.com or by contacting one of our experienced sales engineers.

Terminal Head Mount Models	5331	5333	5334	5335	5350
RTD/R Transmitter	✓	✓		✓	✓
TC/mV Transmitter	✓		✓	✓	✓
Galvanic Isolation	1500 VAC		1500 VAC	1500 VAC	1500 VAC
Channels	1	1	1	1	1
Basic Accuracy Pt100	<± 0.2°C	<± 0.3°C		<± 0.1°C	<± 0.1°C
Temperature Coefficient (*)	<± 0.01%	<± 0.01%	<± 0.01%	<± 0.005%	<± 0.002%
NAMUR NE21 A	✓	✓	✓	✓	✓
DIN Form B Housing	✓	✓	✓	✓	✓
Analog Output	✓	✓	✓	✓	
Digital Output					
PC Programmable	✓	✓	✓	✓	
Bus Programming					✓

(*) % of Span/°C

DIN Rail Mount Models	6331	6333	6334	6335	6350
RTD/R Transmitter	✓	✓		✓	✓
TC/mV Transmitter	✓		✓	✓	✓
Galvanic Isolation	500 VAC		1500 VAC	1500 VAC	1500 VAC
Channels	1 or 2	1 or 2	1 or 2	1 or 2	1 or 2
Basic Accuracy Pt100	<± 0.2°C	<± 0.3°C		<± 0.1°C	<± 0.1°C
Temperature Coefficient (*)	<± 0.01%	<± 0.01%	<± 0.01%	<± 0.005%	<± 0.002%
NAMUR NE21 A	✓	✓	✓	✓	✓
DIN Form B Housing	✓	✓	✓	✓	✓
Analog Output	✓	✓	✓	✓	
Digital Output					
mA to Bus Communication				✓	✓
PC Programmable	✓	✓	✓	✓	
Bus Programming					✓

(*) % of Span/°C

Transmitter Product Certifications

Terminal Head Mount Models	5331A	5331D	5333A	5333D	5334A	5334D	5335A	5335D	5350A	5350D
EC Declaration of Conformity	✓	✓	✓	✓	✓	✓	✓	✓	✓	✓
ATEX		✓		✓		✓	✓	✓	✓	✓
UL									✓	✓
CSA		✓		✓				✓	✓	✓
FM		✓		✓				✓	✓	✓
Marine	✓	✓	✓	✓	✓	✓	✓	✓	✓	✓
NEPSI									✓	✓
SIL							✓	✓		
GOST		✓		✓		✓		✓		✓

DIN Rail Mount Models	5331A	5331D	5333A	5333D	5334A	5334D	5335A	5335D	5350A	5350D
EC Declaration of Conformity	✓	✓	✓	✓	✓	✓	✓	✓	✓	✓
ATEX		✓		✓		✓		✓	✓	✓
UL										
CSA								✓	✓	✓
FM								✓	✓	✓
Marine										
NEPSI										
SIL							✓	✓		
GOST		✓		✓		✓		✓		✓

Marine Approval: Det Norse Veritas, Ships and Offshore

NEPSI: National Supervision and Inspection Center for Explosion Protection and Safety of Instrumentation

SIL: Safety Integrity Level Assessment (IEC 61508)

GOST: Originally a series of Russian State Standards now administered by the Euro-Asian Council for Standardization, Metrology and Certification (EASC)

Thermowells (TW) are pressure-tight receptacles that extend the life of a temperature sensor in environments where the sensor is not chemically compatible with the process media or the sensor does not have the mechanical strength to withstand the process flow or pressure. TWs also facilitate removing, changing, checking or replacing sensors without draining the process system. The use of standardized TWs throughout a plant permits easy relocation of sensors.

In designing a system using TWs, a number of factors must be considered:

Material of Construction

TW material must be chemically compatible with the process system and the temperature sensor. In most cases, TW selection is based on the corrosive conditions in the TW environment. Sometimes the selection may be based solely on the mechanical strength needed to withstand operating pressure and process flow. Often a combination of factors must be considered. In addition to selecting the proper base material, coatings may be used to improve a TW's resistance to abrasion or the chemical process.

The TW wall must be thin enough to minimize sensor error caused by thermal conduction and slow sensor response, but thick enough to withstand collapse from process pressure, erosion from abrasive media and bending from the process flow.

Spring-load mounting styles are recommended to ensure positive contact to maximize thermal transfer and minimize sensor vibration within a TW.

Insertion Length

The insertion length or "U" length is the distance from the end of the well to the underside of the TW thread or other connection device. For maximum accuracy, this length must be long enough to permit the temperature sensor to be fully immersed in the media to be measured and minimize sensor error caused by thermal conduction, but short enough to withstand damage caused by process flow vibration. As a general rule of thumb, the TW should extend into the process a minimum of 10 times the sensor diameter or, in the case of RTDs, 10 times the sensor diameter plus one inch. This should extend the sensor into the process between 1/3 and 1/2 the diameter of the process pipe. The insertion length must also take into consideration any dead length required to pass through walls, pipe fittings and insulation.

ASME PTC 19.3 TW-2010 Compliance

Depending upon the particular TW geometry configuration and process conditions such as fluid media, temperature, pressure, and flow velocity – damaging vortices can be generated on the downstream side of the TW. If the oscillation frequency of these vortices match the natural frequency of the TW it can potentially result in catastrophic failure of the TW.

Historically, ASME's Performance Test Code 19.3 has provided the technical basis for analyzing various TW configurations to ensure they are robust enough to safely handle process conditions. Unfortunately past versions of this code limited the type of TW configurations that could be analyzed and the analysis methodology was somewhat simplified which essentially overlooked some other possible failure conditions. In July 2010, ASME PTC 19.3 TW-2010 was introduced which completely revamped the TW analysis methodology and increased the scope of the different TW configurations that could be analyzed to more accurately predict whether or not a given TW is acceptable for its intended application. As part of the code's new analysis methodology, TW configurations are now analyzed for both In-line and Transverse Resonance conditions and techniques can be used to simulate cases where a portion of the TW is partially shielded from the flow stream.

Conax invites you to submit your TW application details (*using a Wake Frequency Form on pg. 81*) to our experienced engineering team for them to analyze the configuration against the latest ASME PTC 19.3 TW-2010 requirements to determine if an acceptable design is obtained.

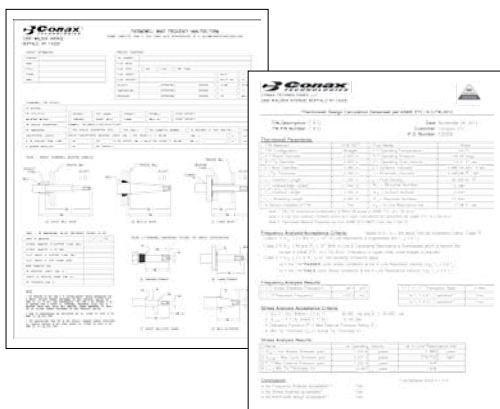
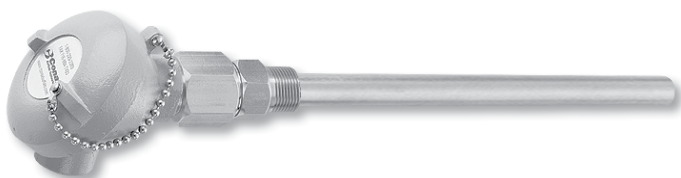

Process Connection

Conax Technologies provides standardized TWs in most of the common connection types, including threaded, flanged and socket weld types with standard bore sizes. Threaded TWs are available in materials that can be readily welded. Flanged TWs are manufactured by welding a bar stock well to the specified flange style. Double-welded construction reduces crevice corrosion and stress problems by ensuring that no open joints are exposed inside or outside the installation. Socket-weld TWs can be easily installed by merely welding the TW into a mating socket.

Bore Size

Selection of a standard bore size throughout the plant permits the use of several types of temperature measuring instruments in the same TWs. Conax standard bore sizes fit most commonly used temperature sensing devices. Most applications use 0.260" (6.604mm) or 0.385" (9.779mm) diameter bores. This number represents the inside diameter of the well, expressed in thousandths of an inch.

Standard Manufacturing Practices

Conax thermowells are constructed to the following tolerances/descriptions:

Item	Tolerance/Description
Lengths	±.062" on lengths 12" or less ±.125" on lengths over 12"
O.D. Tolerances	±0.015"
Bore I.D.	+0.005" -0.003"
End Thickness	.25" ±.062"
Concentricity of Bore to O.D.	±10% of minimum wall thickness
Wetted Surfaces Finish	16-32 Ra is standard. Special finishes are available on request.
Process Connection Thread	In compliance with ANSI B1.20.1-92. Thread specifications vary with the process connection size.
Instrument Connection	1/2-14 NPT standard, 1/2-14 NPSM optional*
End of Thermowells	Break corners, no burrs
Lagging Extension	Hex on threaded thermowells (or wrench flats where applicable)
Stamping	Type of material standard; customer name and heat or tag number if required.
Flanges	Made in accordance with ANSI B16.5. Raised face is serrated 125/250 RMS STD
Welding	Full penetration welds are standard on 300 lb. and up

* Pending availability, NPSM instrument connection may be substituted for NPT.

Thermowell Catalog Descriptions

The following format is used when ordering thermowells. When ordering a thermowell by itself, the initials "TW" precede the description. When ordering a thermowell as part of an assembly, the thermowell description immediately follows the mounting style designation, replacing the sensor active length.

Thermowell:
TW, .50-260S-U5.00-S316

Assembly:
E-SS25-U-T5AL(CSLW)-.50-260S-U5.00-S316

Important Note:
All thermowell dimensions on pages 54 to 65 are in inches.

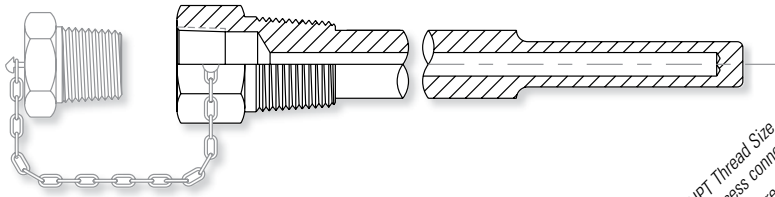

Example: **.50-260S-U 7.50-S316,T=3.50", BRASS PLUG & CHAIN**

NPT Thread Size (process connection) —
 Bore Diameter —
 Well Type —
 Insertion Length Designator —
 Material of Construction —
 Insertion Length —
 Additional Information (e.g., cap and chain, T = Lagging Extension Length if not standard)

NPT Thread Size	Bore Diameter	Well Type	Insertion Length Designator	Insertion Length in Inches (2.50" min.)	Material of Construction	Additional Information
.50 = 1/2 NPT .75 = 3/4 NPT 1.00 = 1 NPT	260 - for 0.250" diameter probes 385 - for 0.375" diameter probes	S – Standard (straight shank) H – Heavy Duty (tapered shank) L – Lagging Extension (straight shank) HL – Heavy Duty with Lagging Extension (tapered shank)	U		S304 – Stainless Steel S316 – 316 Stainless Steel CS – Carbon Steel BRASS – Brass	

Note: Specific material grade specifications may be added to callout, e.g. S316(A182). Other materials (titanium, Hastelloy, Monel, S316L, etc.) are available. Consult factory for details.

Ordering Information

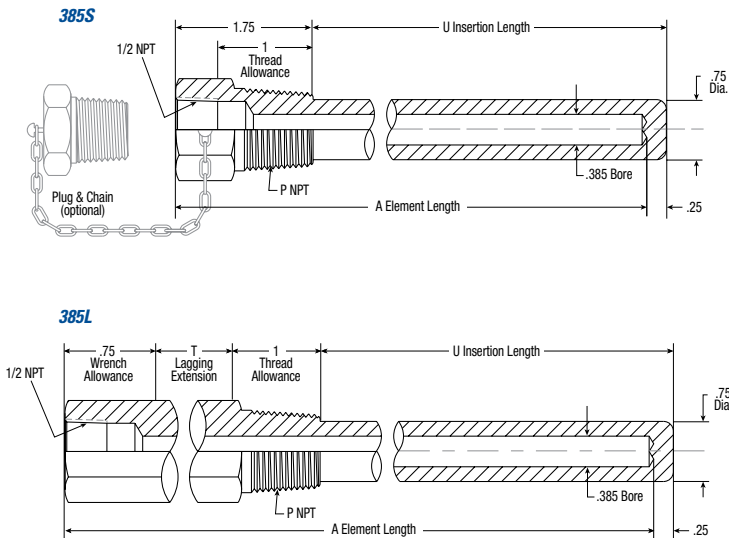

External Thread P	Type Number	Lag. Ext. T	Elem. Length A	Insert Length U	
3/4 NPT	385S	U 2.50	—	4	2.50
		U 4.50	—	6	4.50
		U 7.50	—	9	7.50
		U 10.50	—	12	10.50
		U 13.50	—	15	13.50
		U 16.50	—	18	16.50
1 NPT	385S	U 22.50	—	22	22.50
		U 2.50	—	4	2.50
		U 4.50	—	6	4.50
		U 7.50	—	9	7.50
		U 10.50	—	12	10.50
		U 13.50	—	15	13.50
3/4 NPT	385L	U 16.50	—	18	16.50
		U 22.50	—	24	22.50
		U 2.50	2	6	2.50
		U 4.50	3	9	4.50
		U 7.50	3	12	7.50
		U 10.50	3	15	10.50
1 NPT	385L	U 13.50	3	18	13.50
		U 19.50	3	24	19.50
		U 2.50	2	6	2.50
		U 4.50	3	9	4.50
		U 7.50	3	12	7.50
		U 10.50	3	15	10.50
1 NPT	385L	U 13.50	3	18	13.50
		U 19.50	3	24	19.50
		U 2.50	2	6	2.50
		U 4.50	3	9	4.50

Ordering Information

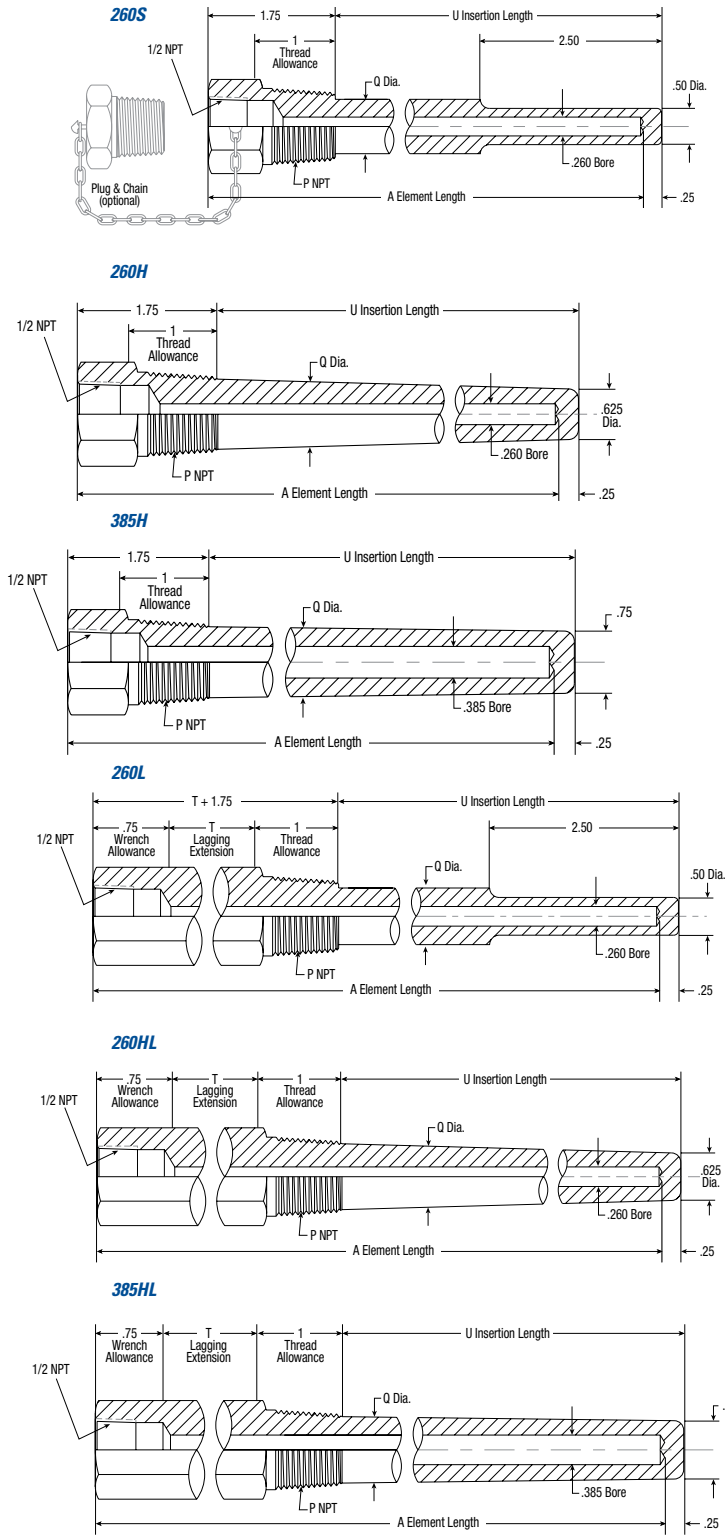

External Thread P	Type Number	Lag. Ext. T	Elem. Length A	Insert Length U	Shank Diameter Q	
1/2 NPT	260S	U 2.50	4	2.50	—	
		U 4.50	6	4.50	.625	
		U 7.50	9	7.50	.625	
		U 10.50	12	10.50	.625	
		U 16.50	18	16.50	.625	
		U 22.50	24	22.50	.625	
3/4 NPT	260S	U 2.50	4	2.50	—	
		U 4.50	6	4.50	.750	
		U 7.50	9	7.50	.750	
		U 10.50	12	10.50	.750	
		U 16.50	18	16.50	.750	
		U 22.50	24	22.50	.750	
	260H 385H	U 2.50	4	2.50	.875	
		U 4.50	6	4.50	.875	
		U 7.50	9	7.50	.875	
		U 10.50	12	10.50	.875	
		U 13.50	15	13.50	.875	
		U 16.50	18	16.50	.875	
1 NPT	260S	U 2.50	4	2.50	.875	
		U 4.50	6	4.50	.875	
		U 7.50	9	7.50	.875	
		U 10.50	12	10.50	.875	
		U 13.50	15	13.50	.875	
		U 16.50	18	16.50	.875	
	260H 385H	U 2.50	4	2.50	1.062	
		U 4.50	6	4.50	1.062	
		U 7.50	9	7.50	1.062	
		U 10.50	12	10.50	1.062	
		U 13.50	15	13.50	1.062	
		U 16.50	18	16.50	1.062	
	1/2 NPT	260L	U 2.50	2	2.50	—
			U 4.50	3	4.50	.625
			U 7.50	3	7.50	.625
			U 10.50	3	10.50	.625
			U 13.50	3	13.50	.625
			U 19.50	3	19.50	.625
3/4 NPT	260L	U 2.50	2	2.50	.750	
		U 4.50	3	4.50	.750	
		U 7.50	3	7.50	.750	
		U 10.50	3	10.50	.750	
		U 13.50	3	13.50	.750	
		U 19.50	3	19.50	.750	
	260HL 385HL	U 2.50	2	2.50	.875	
		U 4.50	3	4.50	.875	
		U 7.50	3	7.50	.875	
		U 10.50	3	10.50	.875	
		U 13.50	3	13.50	.875	
		U 19.50	3	19.50	.875	
1 NPT	260L	U 2.50	2	2.50	.875	
		U 4.50	3	4.50	.875	
		U 7.50	3	7.50	.875	
		U 10.50	3	10.50	.875	
		U 13.50	3	13.50	.875	
		U 19.50	3	19.50	.875	
	260HL 385HL	U 2.50	2	2.50	1.062	
		U 4.50	3	4.50	1.062	
		U 7.50	3	7.50	1.062	
		U 10.50	3	10.50	1.062	
		U 13.50	3	13.50	1.062	
		U 19.50	3	19.50	1.062	

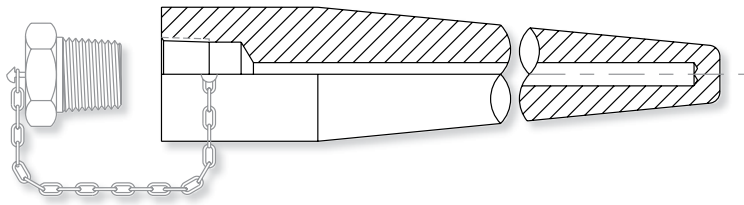

Example: **1.50-260WELD-IN-U 7.50-S316,T=3.50"**

— Pipe Size (outside diameter of well)
 — Bore Diameter
 — Well Type
 — Insertion Length Designator
 — Insertion Length
 — Material of Construction
 — Additional Information (e.g., cap and chain, T = Lagging Extension Length if not standard)

Pipe Size	Bore Diameter	Well Type	U	Insertion Length in Inches (2.50" min.)	Material of Construction	Additional Information
1.50"	260 - for 0.250" diameter probes 385 - for 0.375" diameter probes	WELD-IN			S304 – Stainless Steel S316 – 316 Stainless Steel F11 – Chrome Molybdenum Steel F22 – Chrome Molybdenum Steel F91 – Chrome Molybdenum Steel CS – Carbon Steel	

Note: Specific material grade specifications may be added to callout, e.g. S316(A182). Other materials (titanium, Hastelloy, Monel, S316L, etc.) are available. Consult factory for details.

Ordering Information

260 WELD-IN

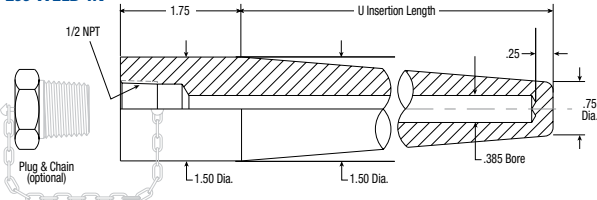

385 WELD-IN

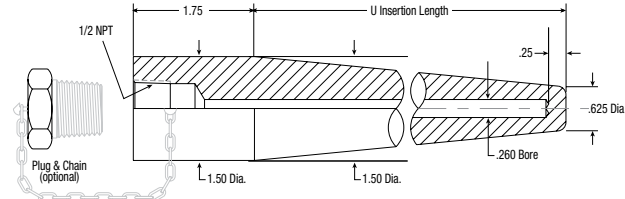

Pipe Size	Type Number	Elem. Length A	Insert Length U	Bore Diameter B
1.50"	260 WELD-IN	U 2.50	2.50	0.260
		U 4.50	4.50	
		U 7.50	7.50	
		U 10.50	10.50	
		U 13.50	13.50	
		U 16.50	16.50	
		U 22.50	22.50	
1.50"	385 WELD-IN	U 2.50	2.50	0.385
		U 4.50	4.50	
		U 7.50	7.50	
		U 10.50	10.50	
		U 13.50	13.50	
		U 16.50	16.50	
		U 22.50	22.50	

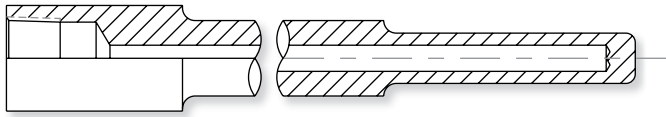

Example: **.75-260W-U 7.50-S316,T=3.50"**

— Pipe Size (outside diameter of well)
 — Bore Diameter
 — Well Type
 — Insertion Length Designator
 — Insertion Length
 — Material of Construction
 — Additional Information (e.g., cap and chain, T = Lagging Extension Length if not standard)

Pipe Size	Bore Diameter	Well Type	U	Insertion Length in Inches (2.50" min.)	Material of Construction	Additional Information
.75 (1.050" OD) 1.00 (1.315" OD)	260 - for 0.250" diameter probes 385 - for 0.375" diameter probes	W – Socket Weld (straight shank) WH – Heavy Duty Socket Weld (tapered shank) WL – Socket Weld with Lagging Extension (straight shank) WHL – Heavy Duty Socket Weld with Lagging Extension			S304 – Stainless Steel S316 – 316 Stainless Steel F11 – Chrome Molybdenum Steel F22 – Chrome Molybdenum Steel F91 – Chrome Molybdenum Steel CS – Carbon Steel	

Note: Specific material grade specifications may be added to callout, e.g. S316(A182). Other materials (titanium, Hastelloy, Monel, S316L, etc.) are available. Consult factory for details.

Ordering Information

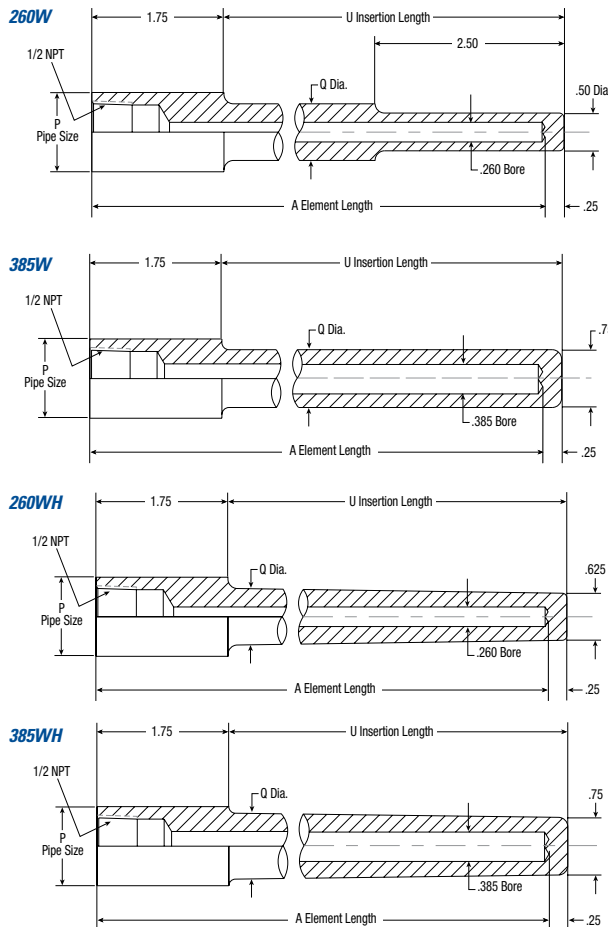

Pipe Size P	Type Number	Elem. Length A	Insert Length U	Shank Diameter Q	
3/4" Nominal (1.050 diameter)	260W 385W	U 2.50	4	2.50	–
		U 4.50	6	4.50	.750
		U 7.50	9	7.50	.750
		U 10.50	12	10.50	.750
		U 13.50	15	13.50	.750
		U 16.50	18	16.50	.750
1" Nominal (1.315 diameter)	260W 385W	U 2.50	4	2.50	–
		U 4.50	6	4.50	.875
		U 7.50	9	7.50	.875
		U 10.50	12	10.50	.875
		U 13.50	15	13.50	.875
		U 16.50	18	16.50	.875
3/4" Nominal (1.050 diameter)	260WH 385WH	U 2.50	4	2.50	.875
		U 4.50	6	4.50	.875
		U 7.50	9	7.50	.875
		U 10.50	12	10.50	.875
		U 13.50	15	13.50	.875
		U 16.50	18	16.50	.875
1" Nominal (1.315 diameter)	260WH 385WH	U 2.50	4	2.50	1
		U 4.50	6	4.50	1
		U 7.50	9	7.50	1
		U 10.50	12	10.50	1
		U 13.50	15	13.50	1
		U 16.50	18	16.50	1

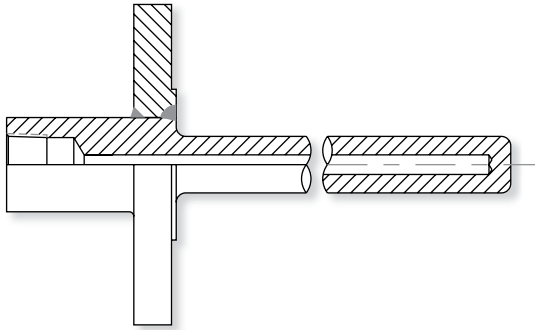

Example: **260F-U 22.50-RF39(S304)-S316,T=3.50"**

Bore Diameter
 Flange Well Type
 Ins. Length Designator
 Insertion Length
 Flange Designator
 Flange Class
 Flange Pipe Size
 Flange Material of Construction
 Well Material of Construction
 Additional Information

Bore Diameter	Flange Well Type	Ins. Length Designator	Insertion Length (2.50" min.)	Flange Designator	Flange Class	Flange Pipe Size	Flange Material of Construction	Well Material of Construction	Additional Information
260 - for 0.250" diameter probes		U		RF			()		
385 - for 0.375" diameter probes		F – ANSI Flange (straight shank)			1 = 150 lb.	4 = .50"	S304 – Stainless Steel		
		FH – Heavy Duty Flange (tapered shank)			2 = 300 lb.	5 = .75"	S316 – 316 Stainless Steel		
		FL – Flange with Lagging Extension (straight shank)			3 = 600 lb.	6 = 1.00"	CS – Carbon Steel		
		FHL – Heavy Duty Flange with Lagging Extension (tapered shank)			4 = 900 lb.	8 = 1.50"			
					5 = 1500 lb.	9 = 2.00"			
					6 = 2500 lb	16 = 8.00"			

Note: Specific material grade specifications may be added to callout, e.g. S316(A182). Other materials (titanium, Hastelloy, Monel, S316L, etc.) are available. Consult factory for details.

Ordering Information

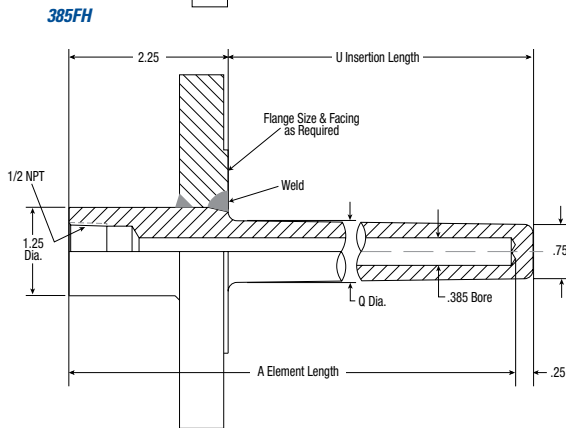
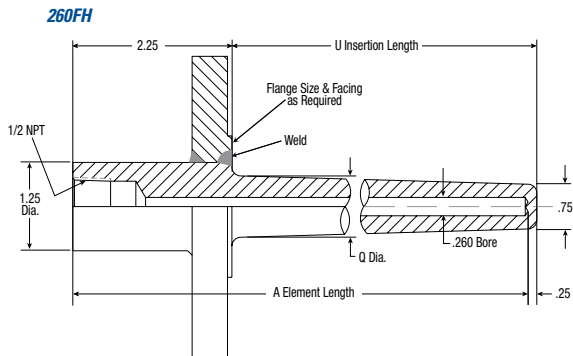
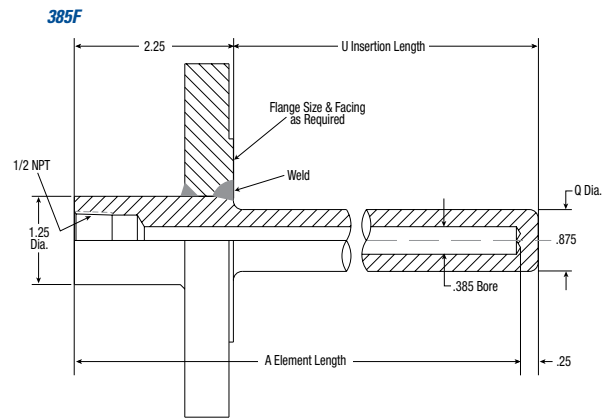
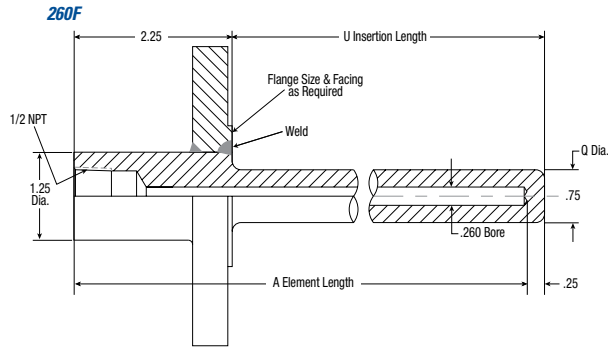

Type Number	Elem. Length A	Insert Length U	Shank Diameter Q	Bore Diameter B
260F	U 2	4	.750	0.260
	U 4	6	.750	
	U 7	9	.750	
	U 10	12	.750	
	U 13	15	.750	
	U 16	18	.750	
385F	U 2	4	.875	0.385
	U 4	6	.875	
	U 7	9	.875	
	U 10	12	.875	
	U 13	15	.875	
	U 16	18	.875	
260FH	U 2	4	.875	0.260
	U 4	6	.875	
	U 7	9	.875	
	U 10	12	.875	
	U 13	15	.875	
	U 16	18	.875	
385FH	U 2	4	.875	0.385
	U 4	6	.875	
	U 7	9	.875	
	U 10	12	.875	
	U 13	15	.875	
	U 16	18	.875	

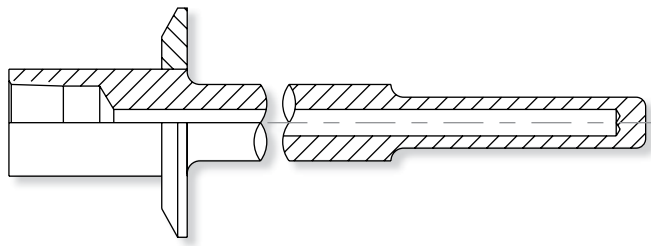

Example: **.75-260W(SFA10/S316)-U 7.50-S316,T=3.50"**

Pipe Size (outside diameter of well) —
 Bore Diameter —
 Well Type —
 Designator for Sanitary Flange Assembly —
 Sanitary Flange Size —
 Sanitary Flange Material of Construction —
 Insertion Length Designator —
 Insertion Length —
 Well Material of Construction —
 Additional Information (e.g., cap and chain, T = Lagging Extension Length if not standard)

Pipe Size	Bore Diameter	Well Type	(SFA	Sanitary Flange Size (16 AMP))	U	Sanitary Flange Material	Ins. Length Designator	Insertion Length (2.50" min.)	Well Material of Construction	Additional Information
.75 (1.050 OD)	260 - for 0.250" diameter probes 385 - for 0.375" diameter probes		W – Socket Weld (straight shank) WH – Heavy Duty Socket Weld (tapered shank) WL – Socket Weld with Lagging Extension (straight shank) WHL – Heavy Duty Socket Weld with Lagging Extension				S316L – 316L stainless steel standard			S304 – Stainless Steel S316L – 316L Stainless Steel	
							Note: Other materials are available. Consult factory for details. 10 = 1.0" & 1.5"* 20 = 2.0" 25 = 2.5" 30 = 3.0" 40 = 4.0"				
							Note: Other materials are available. Consult factory for details.				

Ordering Information

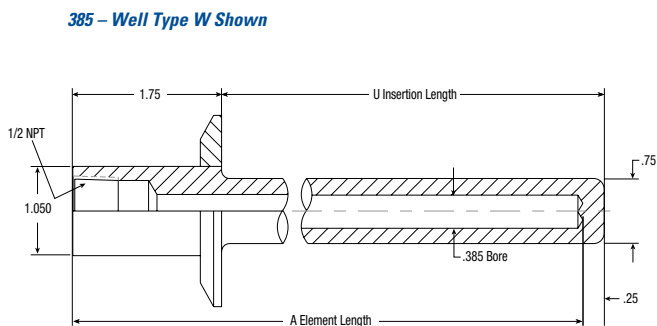
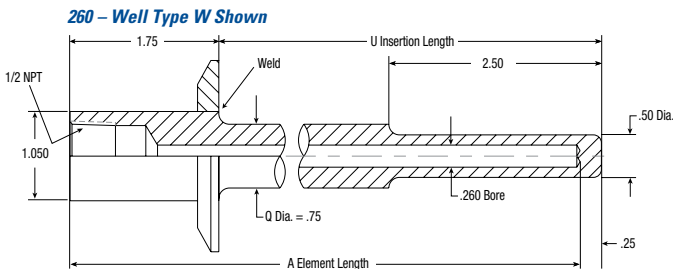

Type Number	Elem. Length A	Insert Length U	Shank Diameter Q	
260 Sanitary	U 2-.50	4	2.50	–
	U 4-.50	6	4.50	.75
	U 7-.50	9	7.50	.75
	U 10-.50	12	10.50	.75
	U 13-.50	15	13.50	.75
	U 16-.50	18	16.50	.75
385 Sanitary	U 2-.50	4	2.50	.75
	U 4-.50	6	4.50	.75
	U 7-.50	9	7.50	.75
	U 10-.50	12	10.50	.75
	U 13-.50	15	13.50	.75
	U 16-.50	18	16.50	.75
U 22-.50	24	22.50	.75	

*Note: SFA10 available for .75 pipe size only.

Limited Space Thermowells

Ordering Information

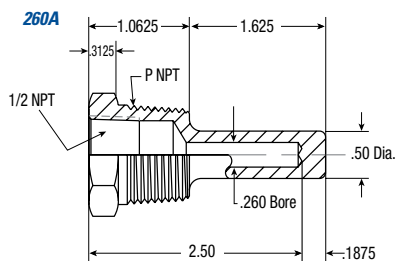

External Thread P	Type Number	Well Type	Material
3/4 NPT	3/4-260A-U1-5/8	3/4-260A	Brass
			Carbon Steel
			A.I.S.I. 304
			A.I.S.I. 316
			Monel
1 NPT	1-260A-U1-5/8	1-260A	Brass
			Carbon Steel
			A.I.S.I. 304
			A.I.S.I. 316
			Monel

Van Stone Thermowells

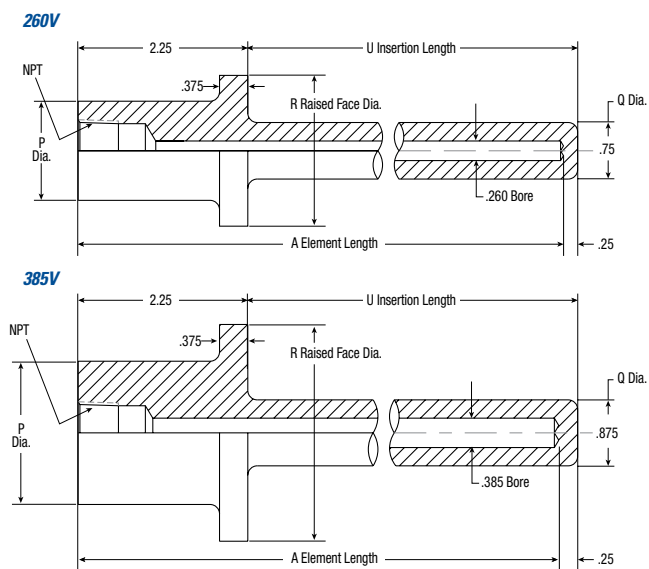

Ordering Information

Type Number	Elem. Length A	Insert Length U	Shank Dia. Q	Bore Dia. B
260V	U 2	4	.75	0.260
	U 4	6	.75	
	U 7	9	.75	
	U 10	12	.75	
	U 13	15	.75	
	U 16	18	.75	
385V	U 2	4	.875	0.385
	U 4	6	.875	
	U 7	9	.875	
	U 10	12	.875	
	U 13	15	.875	
	U 16	18	.875	
U 22	24	.875		

Pipe Size Nominal	Actual Dia. P	Raised Face Dia. R
1	1.315	2
1.500	1.900	2.875

Conax offers protection tubes in a variety of types and materials. Protection tubes are intended for use in applications where the tube will not be exposed to high pressure or fluid velocities. Pipewells, made from Schedule 40, 80 or 160 pipe, are the most commonly used form of protection tube. Mounting is generally achieved through a flange or threaded bushing welded to the pipe.

Pipewell Catalog Description

The following format is used when ordering pipewells. When ordering a pipewell by itself, the initials "PW" precede the description. When ordering a pipewell as part of an assembly, the pipewell description immediately follows the mounting style designation, replacing the sensor active length.

Pipewell: *PW, .50X40/S316-L24.00-R*

Assembly: *E-SS25-U-T5AL(CSLWC)-.50X40/S316-L24.00-R*

Pipewell with Mounting Flange

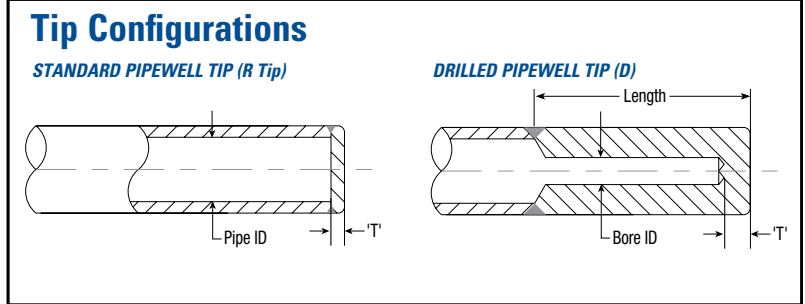
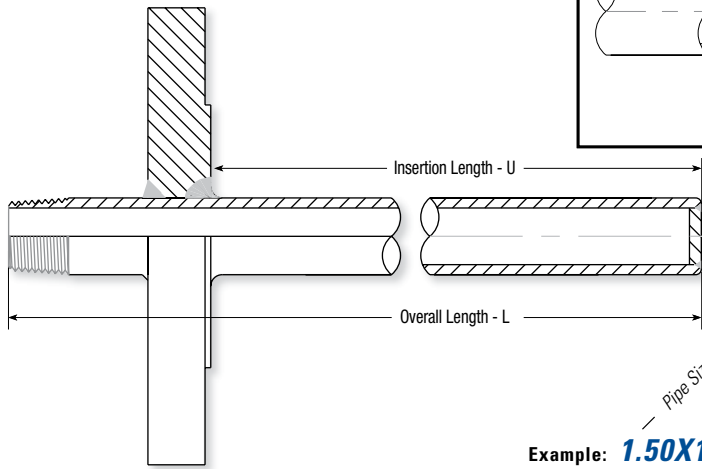

Example: **1.50X160/S316-L24.00-R(260-4)-RF29(S316)-U18.00**

Labels for the example: Pipe Size, Pipe Schedule, Pipewell Material of Construction, Length Designator, Overall Length, Tip Configuration, Flange Type, Flange Pipe Size, Flange Material of Construction, Insertion Length Designator, Insertion Length.

Pipe Size	Pipe Schedule	Pipewell Material of Construction	Length Designator	Overall Length in Inches	Tip Config.	Flange Type	Flange Class	Flange Pipe Size	Flange Material of Construction	Ins. Length Designator	Insertion Length in Inches	
40		S304 – Stainless Steel			R = Round*		1 = 150 lb.	4 = .50"			S304 – Stainless Steel	
80		S316 – 316 Stainless Steel			D = Drilled Bar Stock		2 = 300 lb.	5 = .75"			S316 – 316 Stainless Steel	
160		CS – Carbon Steel			Example: D (260-3)			6 = 1.00"			CS – Carbon Steel	
		Note: Other materials are available. Consult factory for details.						8 = 1.50"			Note: Specific material grade specifications may be added to callout, e.g. S316(A182). Other materials (titanium, Hastelloy, Monel, S316L, etc.) are available. Consult factory for details.	
					ID of Bore (thousandths of an inch)	Length of Bar Stock (3-6", .5" increments)		9 = 2.00"				
					• 260 - 0.250" diameter probes	• 385 - 0.375" diameter probes		16 = 8.00"				
					*Full radius tip configuration may be substituted.							
							FF = Flat Faced					
							RF = Raised Faced					

Pipewell Only

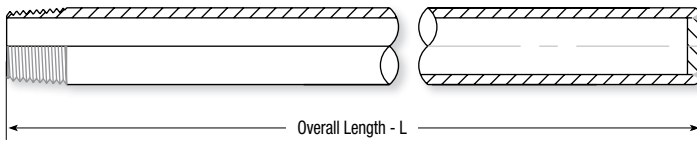

Example: **1.50X160/S316-L25.00-R**

Labels: Pipe Size, Pipe Schedule, Material of Construction, Length Designator, Overall Length, Tip Configuration

Pipe Size	Pipe Schedule	Material of Construction	Overall Length Designator	Length in Inches	Tip Configuration	Optional Information
.50 = .840" OD	40	S304 – Stainless Steel	L		R = Round	Special surface finishes, etc.
.75 = 1.050" OD	80	S316 – 316 Stainless Steel			D = Drilled Bar Stock	
1.00 = 1.315" OD	160	CS – Carbon Steel			Example: D (260-3)	
1.50 = 1.900" OD					ID of Bore (thousandths of an inch)	Length of Bar Stock (3-6", .5" increments)
2.00 = 2.375" OD					• 260 - 0.250" diameter probes	• 385 - 0.375" diameter probes

Note: Specific material grade specifications may be added to callout, e.g. S316(A182). Other materials (titanium, Hastelloy, Monel, S316L, etc.) are available. Consult factory for details.

Pipewell with Mounting Plug

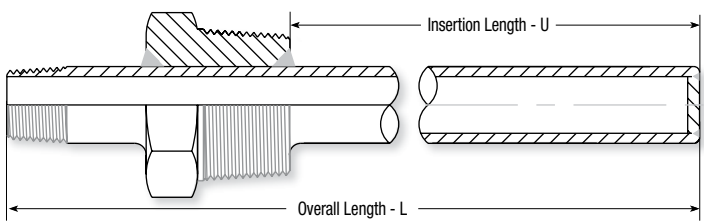

Example: **1.50X160/S316-L24.00-R-PTM9(S316)-U18.00**

Labels: Pipe Size, Pipe Schedule, Pipewell Material of Construction, Length Designator, Overall Length, Tip Configuration, Pipe Plug, Pipe Plug Material of Construction, Ins. Length Designator, Insertion Length

Pipe Size	Pipe Schedule	Material of Construction	Length Designator	Overall Length (in.)	Tip Configuration	Drilled Pipe Plug	Pipe Plug Material of Construction	Ins. Length Designator	Insertion Length (in.)
.50 = .840" OD	40	S304 – Stainless Steel	L		R = Round		PTM4 = 1/2 NPT	U	Location of pipe plug on pipe
.75 = 1.050" OD	80	S316 – 316 Stainless Steel			D = Drilled Bar Stock		PTM5 = 3/4 NPT		
1.00 = 1.315" OD	160	CS – Carbon Steel			Example: D (260-3)		PTM6 = 1 NPT	S304 – Stainless Steel S316 – 316 Stainless Steel CS – Carbon Steel	
1.50 = 1.900" OD					ID of Bore (thousandths of an inch)	Length of Bar Stock (3-6", .5" increments)	PTM8 = 1-1/2 NPT		
2.00 = 2.375" OD					• 260 - 0.250" diameter probes	• 385 - 0.375" diameter probes	PTM9 = 2 NPT		
							PTM10 = 2-1/2 NPT		

Note: Other materials are available. Consult factory for details.

Note: Specific material grade specifications may be added to callout, e.g. S316(A182). Other materials (titanium, Hastelloy, Monel, S316L, etc.) are available. Consult factory for details.

Feedthrough Assemblies for the Semiconductor Industry

Conax Technologies meets the demanding needs of the semiconductor industry with a wide range of temperature sensors and compression seals specifically designed for the unique requirements of this industry. We offer standard products that can be easily adapted to meet the most challenging processes and applications of this industry. Our design engineers are continuously working on new sensor and sealing designs to meet the needs of this rapidly changing field. To learn more, please request our Bulletin #6003. The following are typical examples of highly specialized Conax compression seal feedthroughs.



Flanged Power Feedthrough (EG) with Insulated Electrode Extension

Conax EG feedthrough with special long insulated electrode for bringing power into vacuum chamber to power heating elements for polysilicon ingot growth or thin film deposition process. This unit is shown with optional Klamp-Flange® or Kwik-Flange® process connection.

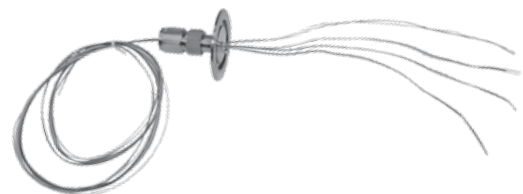

Instrumentation Wire Feedthrough (TG24T)

Conax TG-24T feedthroughs are typically used to pass thermocouple wires or copper signal wires through a vacuum or pressure boundary. TG-24Ts are available in 2 to 24 wire configurations with Teflon insulated, 24 AWG wires. This unit is shown with optional Klamp-Flange or Kwik-Flange process connection



Molybdenum Electrode Feedthrough

This is a specialized molybdenum electrode feedthrough design with a Con-Flat® flange that allows removal of the electrode from the sealing/mounting flange assembly either into the process chamber or out of the process chamber. Internal removal is helpful when maintaining this MOCVD tool after deposition has built up on the electrode. This part is used in the manufacture of very high efficiency compound semiconductor photovoltaic cells.



Copper Electrode Feedthrough

Although not a compression seal feedthrough, this is a sealed electrode feedthrough and an example of a straight machined part that Conax Technologies makes for the high brightness LED manufacturing industry. This electrode is used on an MOCVD tool and is water cooled to allow operation at high current and high temperature.

Compression Seal Feedthroughs for HAST Chambers

HAST (Highly Accelerated Stress Testing) is required in semiconductor fabrication facilities to conduct destructive sample lot testing of high volume production chips. HAST chambers are also used to test next-generation product design/architecture to insure reliability prior to introduction into the market. These test chambers require many wires to pass through from the high-humidity, high-temperature, high-pressure chamber to the ambient environment where data logging equipment monitors the chips' performance. Conax Technologies offers many varieties of copper-wire or thermocouple-wire HAST feedthroughs. The following shows typical examples of these feedthroughs.

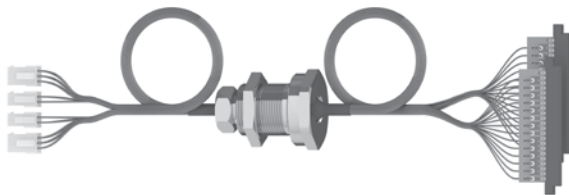

Conax HAST Feedthrough for Nickel Plated Copper Wires with Teflon® Insulation for Bias Measurement



Conax High Capacity Thermocouple Wire HAST Feedthrough with Teflon® Insulated Wires using multiple High Density Feedthroughs

Specialty Thermocouples for the Semiconductor Industry

Conax Technologies manufactures a wide variety of temperature sensors including thermocouples, RTDs and thermistors. For the semiconductor industry, the most popular type of sensors we manufacture is thermocouples which are typically used in high temperature (up to 1200°C) and highly corrosive (ex. hydrochloric acid) environments. Many have semiconductor grade quartz sheaths protecting internal platinum-rhodium thermocouples. The following are typical examples of highly specialized Conax temperature sensors.

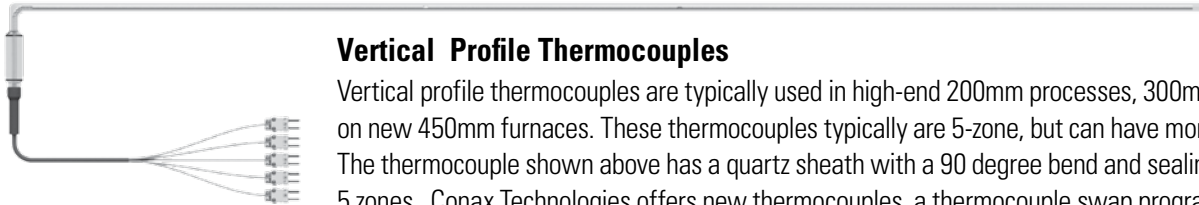

Vertical Profile Thermocouples

Vertical profile thermocouples are typically used in high-end 200mm processes, 300mm processes and on new 450mm furnaces. These thermocouples typically are 5-zone, but can have more or less zones. The thermocouple shown above has a quartz sheath with a 90 degree bend and sealing barrel with 5 zones. Conax Technologies offers new thermocouples, a thermocouple swap program to reclaim platinum/rhodium precious metal content, repair, sheath replacement and recalibration services.

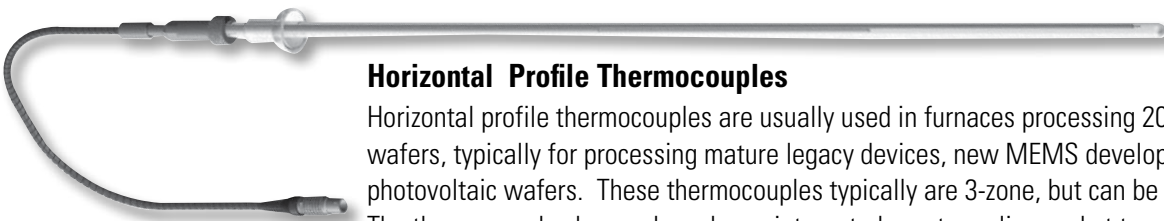

Horizontal Profile Thermocouples

Horizontal profile thermocouples are usually used in furnaces processing 200mm or smaller wafers, typically for processing mature legacy devices, new MEMS development devices, or photovoltaic wafers. These thermocouples typically are 3-zone, but can be 5-zones or more. The thermocouple shown above has an integrated quartz sealing socket to adapt/seal to the furnace process tube.

Spike Thermocouples – Single Spike and Dual Spike

Spike thermocouples are made in a wide variety of tip configurations, diameters, lengths and termination styles to monitor and control heating elements in the different zones of a furnace. The illustration at right shows Single Spike and Dual Spike thermocouples with slotted tips and lead wire terminations.

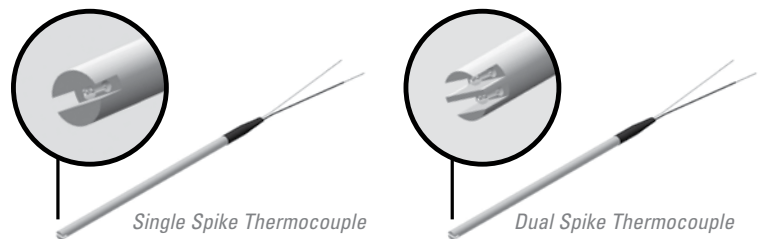

Epitaxial Thermocouples

Conax Technologies has supplied calibration and process control thermocouples for epitaxial tools for over 40 years, starting with the calibration thermocouple for the legacy AMAT Barrel Reactor. Additionally we offer a complete line of thermocouples for the ASM Epsilon® and AMAT Centura®.

Thermocouples for ASM Epsilon Reactors

Conax Technologies has a very extensive line of thermocouples for the ASM Epsilon reactor. Whether you are looking for low-cost/standard life thermocouples all the way to long life thermocouples that will allow longer runs between maintenance cycles; we offer the ability to customize the individual sensor to make up the sensor set that is best for you. To learn more, request Bulletin #6041.

Thermocouples for Applied Materials Centura

Conax Technologies offers the calibration thermocouples for your Centura reactor chamber. Contact us for more details.

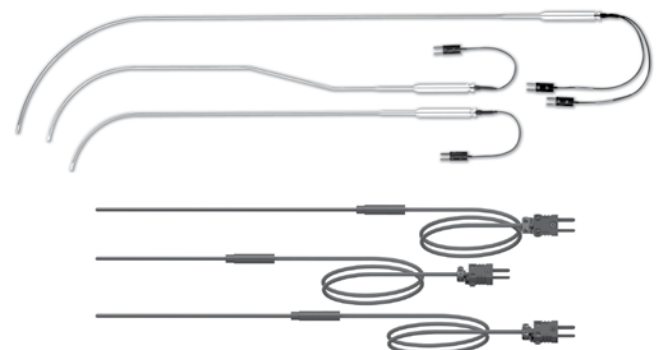



Complete Line of Power Generation OEM Parts

Conax Technologies offers a wide range of OEM parts for various power generation applications. All Conax temperature sensors are designed, machined and assembled in the USA using the finest materials and workmanship available..



Gas Turbine Sensors

Hot Section:

- Exhaust Gas / Blade Path
- Diffuser sensors, outlet turbine control
- Exhaust Rakes
- Wheelspace, Disc Cavity

Inlet and Compressor Section:

- Compressor Discharge thermocouples
- Bearing Temperature Sensors and Wire Seals
- Air Inlet and Lube Oil Temperature Sensors

Steam Turbine Sensors

Conax Technologies offers a complete line of OEM replacement and aftermarket equivalent sensors for steam turbines. We maintain a complete set of OEM drawings for bearing sensors, inner case sensors, outer case sensors and shell sensors (part numbers beginning with U251, U252, U253, U231, U248 and U249).

Sensors can also be manufactured and improved for any turbine manufacturer for HP or LP sections and bearing monitoring. Please provide a drawing, sketch or failed part.

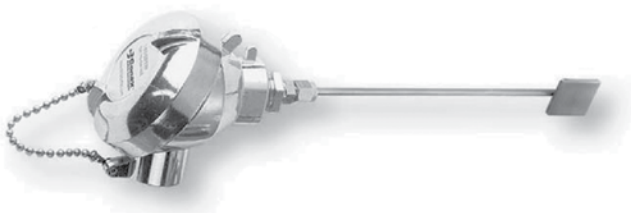

HRSG Sensors and Thermowells

Conax Technologies works with several OEM HRSG manufacturers to provide temperature sensors for superheaters, waste water evaporators, high pressure drum temperatures as well as tube skin temperature measurement. These sensors, usually provided in type K or E conductor material, are manufactured from ASTM E585 grade MI cable. Weld pads matching tube materials and radius are often provided.

Piping Sensors and Thermowells

Conax main steamline thermocouples and RTDs offer the stability and ruggedness required in these piping locations. Made from mineral insulated cable using the highest quality materials, our sensors are designed to meet the challenge. Whatever your application, Conax thermowells are designed to suit your application. Our thermowells are not selected from a catalog list, but designed with the proper metallurgical and flow parameters in mind.

Engineered Solutions for Enhanced Power Generation Performance

Conax Technologies has developed a number of innovative and unique approaches to improve the performance of OEM temperature sensor products.

Longer Life Sensors – Fewer Premature Failures

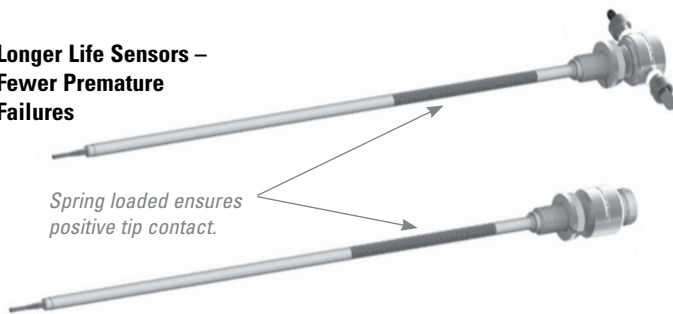

Spring Loaded EGT for GE Frame 7s - Patent Pending

Conax Technologies has designed an innovative and unique approach to exhaust gas temperature sensors. These sensors address the problem of having sensor tips breaking off prematurely in service because the thermal expansion of radiation shields currently causes sensors within them to vibrate appreciably. **See Conax Bulletin #6054E for details.**

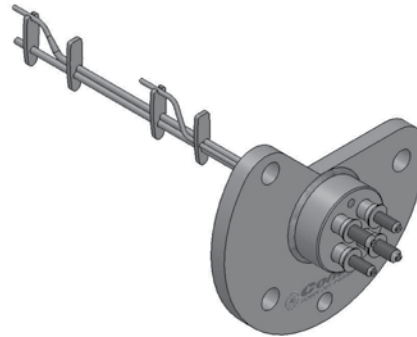

Improved EGT Design for Pratt & Whitney FT8/GC8

The key enhancement of the Conax Technologies innovative and unique design is the use of two (2) dual thermocouple probes rather than four (4) single thermocouple probes. Conax Technologies employs unique manufacturing techniques to create balanced loop resistance between all thermocouples. The result is a more robust and reliable design that offers the same two (2) circuit, four (4) point averaging temperature measurements as an OEM sensor with superior accuracy and reliability. **See Conax Bulletin #6108 for details.**

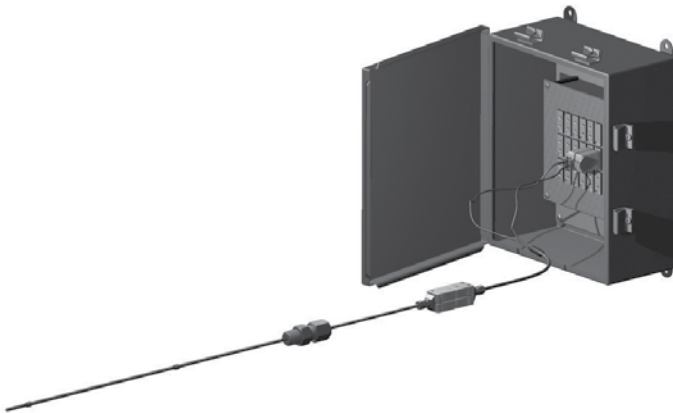

Retrofit Blade Path Thermocouple for Siemens/W-H Turbines

Reduce maintenance time with this new thermocouple arrangement. This quick disconnect assembly allows the cables to be removed during engine maintenance thereby reducing the risk of damaging the thermocouple cables. When sensors do fail, the quick disconnect arrangement allows for quick sensor change out. **See Conax Bulletin #6067 for details.**



Retrofit EGT for Older Frame 5, 6, 7 and 9 Turbines

If you have an older GE Frame turbine, Conax Technologies offers improved replacement exhaust gas thermocouple sensors that fit older radiation shields with base GE P/Ns 351A3711, 238A7864, 219B6376, and 205B3060. This upgrade kit provides a longer lasting sensor that also features lower maintenance time at change out. There is no need to replace the existing radiation shields when using this upgraded exhaust gas sensor. **See Conax Bulletin #6064 for details.**





The bearings of industrial rotating equipment operate under arduous conditions - often for considerable periods of time. The most reliable indicator of bearing condition is the temperature of the metal beneath the shoe.

Recognition of rising temperature can provide a warning of the breakdown of the lubricating oil film, allowing machine shutdown and maintenance to take place before catastrophic failure of the bearing and possible damage to its mounting. Conax Miniature Bearing Sensors provide a simple and cost-effective method to monitor bearing temperatures.



Embedment RTDs and Thermocouples

Maximum Number of Conductors and Wire Gauge (AWG)

Sensor Type	Case Style A ⁶		Case Style B ⁵		Case Style C ⁶		Case Style D ⁶		Case Style E ⁶	
										
	Case L: 0.250" (6.4 mm) Case Ø: 0.275" (7.0 mm)		Case L: 0.250" (6.4 mm) Case Ø: 0.188" (4.8 mm) Flange Ø: 0.250" (6.4 mm)		Case L: 0.300" (7.6 mm) Case Ø: 0.125" (3.2 mm)		Case L: 0.300" (7.6 mm) Case Ø: 0.080" (2.0 mm)		Case L: 0.250" (6.4 mm) Case Ø: 0.250" (6.4 mm)	
	Single ¹	Dual ¹	Single ¹	Dual ¹	Single ¹	Dual	Single ¹	Dual	Single ¹	Dual ¹
Platinum, 100 Ω ± 0.12% at 0°C (Meets EN60751, Class B) ^{2,4}	3 wire 24 AWG	6 wire 24 AWG	3 wire 24 AWG	6 wire 24 AWG	3 wire 26 AWG	6 wire 30 AWG	3 wire 30 AWG	NA	3 wire 24 AWG	6 wire 24 AWG
Thermocouple (E, J, K, T) ³	2 wire 24 AWG	4 wire 24 AWG	2 wire 24 AWG	4 wire 24 AWG	2 wire 26 AWG	NA	2 wire 30 AWG	NA	2 wire 24 AWG	4 wire 24 AWG

¹Smaller wire available - Contact Factory

²Also meets ± .36% Tolerance Band

³Thermocouple (E, J, K, T) - Standard Limits of Error, Special Limits of Error Available - Consult Factory

⁴RTD, Recommended Driving Current - 1mA max

⁵Installation Procedure Request TSD 40.001

⁶Installation Procedure Request TSD 40.003

Specifications

Temperature Range: -40 to 230°C (-40 to 446°F)

Case Materials: 316 SS; Copper; Nickel Plated Copper; Tin Plated Copper, Brass.

Lead Wires: Stranded silver plated copper conductors with PTFE insulation and optional stainless steel overbraid.

Time Constant: 3.0 sec. (Style A) to 1.5 sec. (Style D), Typical value in moving water (3ft/sec (91.4 mm/sec))

Insulation Resistance: 10 Megaohms Min. at 100 VDC, leads to case (RTD)

10 Megaohms Min. at 100 VDC, Ungrounded only (T/C)

Installation and Accessories

Case Style	Installation Instructions	Dimensions
A & E	Install Case Style A sensor just below the babbitt layer, then puddle the babbitt metal over the sensor tip and smooth. Case E is bonded with epoxy near the babbitt face for best readings.	
B (5)	The Spring Steel style retaining ring allows spring loading with the spring and retaining ring (order separately). The Beryllium Copper style retaining ring allows removal and reinstallation. Slide the spring and ring over the leads, insert the sensor tip into a milled hole, and push down on the retaining ring to compress the spring and secure the sensor.	
C & D (6)	Bond with epoxy inside small bearing shoes. Locate near the babbitt face for best readings. Note: SST Overbraid NOT AVAILABLE.	

Retaining Rings		
Style	Ordering P/N	"A" Diameter
1	48-0054-001	0.156" (3.96 mm)
1	48-0054-002	0.136" (3.45 mm)
2	48-0111-001	0.213" (5.4 mm)
To be ordered in conjunction with Case Style B		

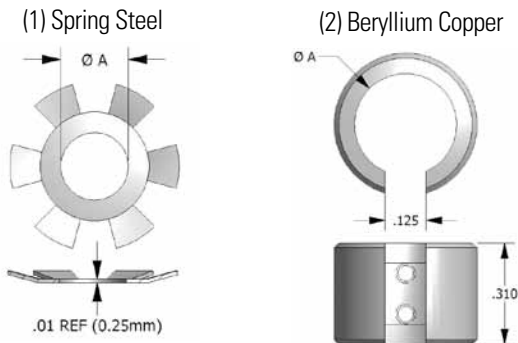

Springs		
Ordering P/N	Length (in.)	Load (lbs.)
6961-37	.44" (11.2mm)	2.75
6961-24	.50" (12.7mm)	2.71
48-0048-003	1.25" (31.8mm)	2.02
48-0048-005	1.75" (44.5mm)	2.02
48-0048-004	2.00" (50.8mm)	2.02
48-0048-001	3.00" (76.2mm)	2.02
To be ordered in conjunction with Case Style B		

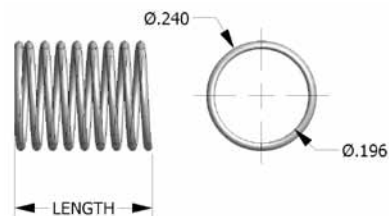

How To Order

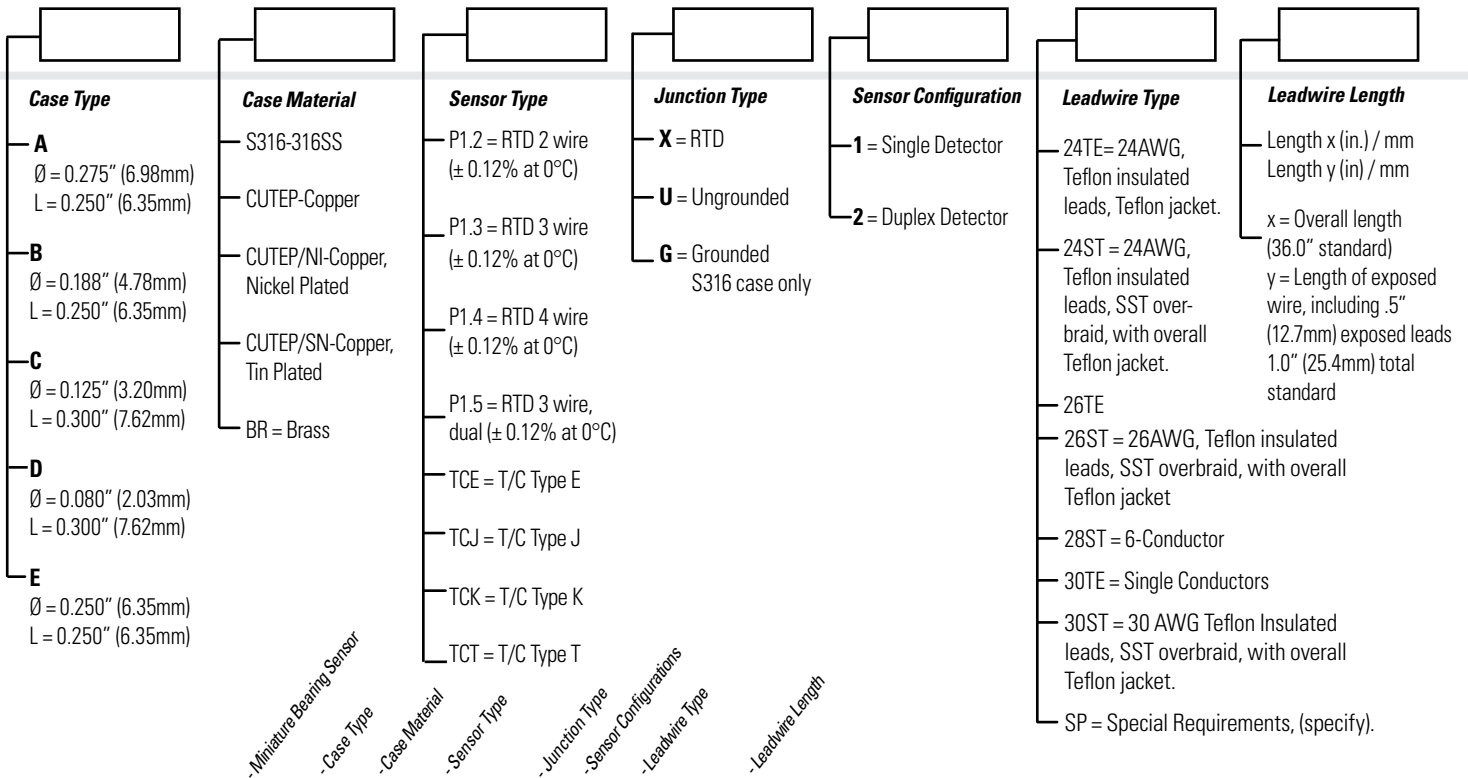

Example: MBS-B-BR-P1.3-X-1-24TE-36.0/1.0

Bearing Sensor Wire Seals (BSWS) - To Prevent Oil Leakage

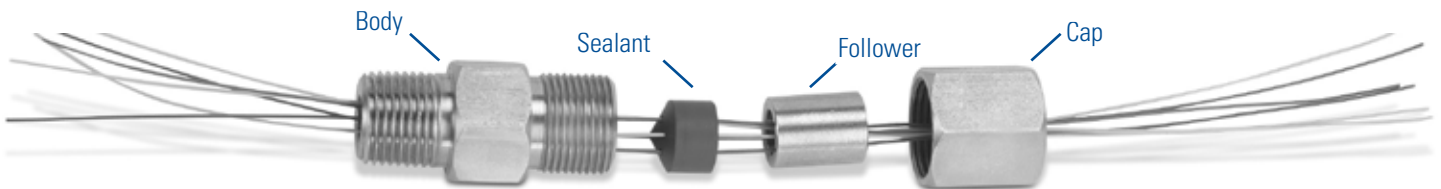

Conax BSWS assemblies were originally designed for use with embedment bearing temperature sensors to prevent oil migrating along the sensor leads. They seal on the individual insulated leads exiting an oil-filled bearing house. They may also be used to seal all types of insulated instrumentation lead wire. These sealing assemblies can be found in large motors, generators, turbines, pumps, compressors and journal bearing pedestals.

Construction consists of 303SST for metallic parts and a sealant made from 'Viton'. Standard assemblies seal 2 to 14 wires in a variety of wire gauges. Please consult Conax Technologies for custom needs.

- Temperature Range: Ambient to $+100^{\circ}\text{F}$ ($+37.8^{\circ}\text{C}$)
- Pressure Range: to 50 psig (3.4 bar)

The replaceable sealant permits repeated use of the same fitting. Elements can be easily assembled or replaced in the field. To replace the sealant or elements, simply loosen the cap, replace the necessary items, re-lubricate and re-torque the cap. See our Catalog 5001 for more information on our BSWS model.

To order a Replacement Sealant, order
 RS – (Fitting) – (Element Size) – (Number of Holes) – V

Example: RS-BSWS4-20-2-V

How To Order (BSWS)

Catalog Numbering System

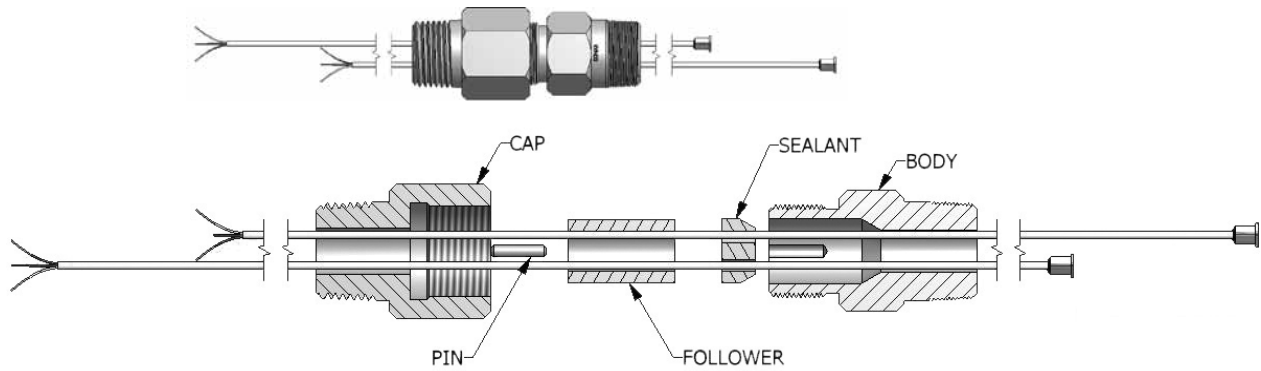
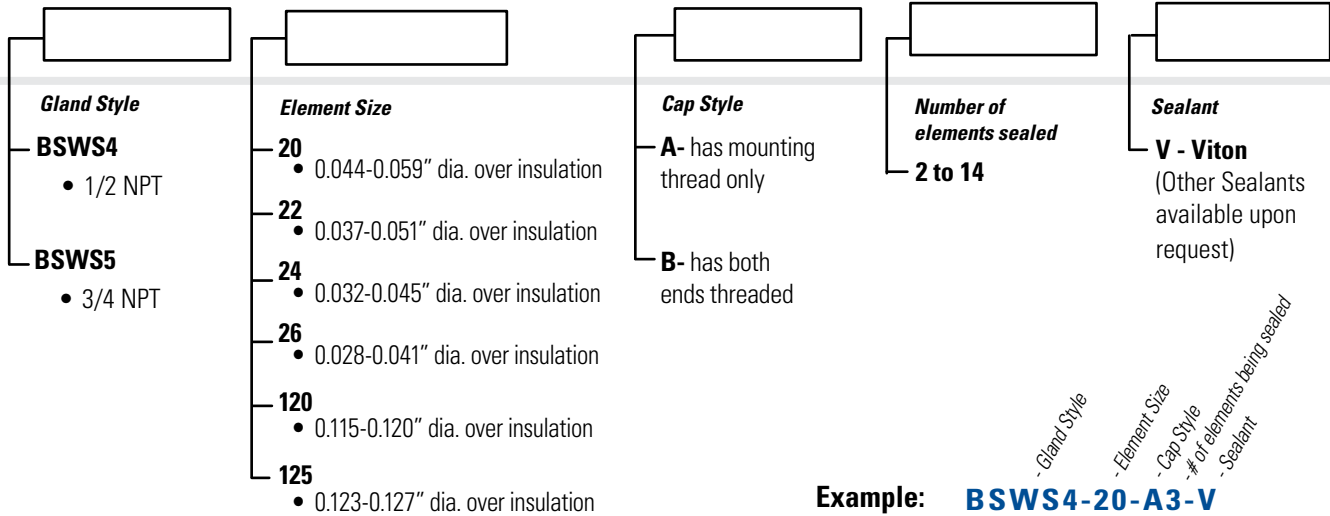

Catalog Number	Number of Wires	Diameter Over Insulation		Thread NPT	Length 'A'		Length 'B'		Hex Size				Pressure Rating Viton	
		IN	MM		IN	MM	IN	MM	Body IN	Cap IN	Body MM	Cap MM	PSIG	BAR
BSWS4-20	2-8	0.044-0.059	1.1-1.5	1/2	2.50	63.5	3.25	82.6	1.000	1.000	25.4	25.4	50	3.4
BSWS4-22	2-8	0.037-0.051	0.9-1.3	1/2	2.50	63.5	3.25	82.6	1.000	1.000	25.4	25.4	50	3.4
BSWS4-24	2-8	0.032-0.045	0.8-1.1	1/2	2.50	63.5	3.25	82.6	1.000	1.000	25.4	25.4	50	3.4
BSWS4-26	2-8	0.028-0.041	0.7-1.0	1/2	2.50	63.5	3.25	82.6	1.000	1.000	25.4	25.4	50	3.4
BSWS5-20	2-14	0.044-0.059	1.1-1.5	3/4	2.88	73.0	3.63	92.1	1.250	1.500	31.8	38.1	50	3.4
BSWS5-22	2-14	0.037-0.051	0.9-1.3	3/4	2.88	73.0	3.63	92.1	1.250	1.500	31.8	38.1	50	3.4
BSWS5-24	2-14	0.032-0.045	0.8-1.1	3/4	2.88	73.0	3.63	92.1	1.250	1.500	31.8	38.1	50	3.4
BSWS5-26	2-14	0.028-0.041	0.7-1.0	3/4	2.88	73.0	3.63	92.1	1.250	1.500	31.8	38.1	50	3.4
BSWS5-120	2-4	0.115-0.120	2.9-3.3	3/4	2.88	73.0	3.63	92.1	1.250	1.500	31.8	38.1	50	3.4
BSWS5-125	2-4	0.123-0.127	3.1-3.2	3/4	2.88	73.0	3.63	92.1	1.250	1.500	31.8	38.1	50	3.4

BSWS assemblies may be purchased with SAE/MS thread mount, weld neck or flange style mounts. Consult factory for details.
 All pressure and torque ratings were determined at 68° F (20° C) using stainless steel rod as the element. Pressure ratings may degrade at higher temperatures.
 Pressure rating guide values are provided for glands with elements restrained by the compressed sealant. Higher pressure may be attained with additional element restraints.
 For proper assembly of these sealing glands, see the Assembly Instructions provided in Catalog 5001.

Flexible Tube Assemblies



Conax Flex-Tube Assemblies protect wires from mechanical abuse. They are available in any length, factory assembled and furnished complete with end fittings (standard male or female pipe thread). Standard end fittings are plated brass or steel. Stainless steel Conax Compression Seal Fittings (PG) may be substituted at additional cost.

Interlock construction uses galvanized steel for .75" (19mm) OD and brass for .375" (9.5mm) OD, both with overall polyvinyl covering.

Ordering Notes:

To order cable and connectors only, order as follows:

FT4-M30

To add a terminal head, order as follows:

B2(FT4-M30), .25NPT

To order as part of a complete assembly, order as follows:

J-SS12-U-B2(FT4-M30)-12.00"

FLEX-TUBE ASSEMBLY SPECIFICATIONS

Catalog Type	Nominal ID IN	MM	Nominal ID IN	MM	NPT Fitting Thread Size	Type of Fitting
FT4-F*	.187	4.8	.375	9.5	1/4"	Female only
FT4-FF*	.187	4.8	.375	9.5	1/4"	Female-Female
FT4-M*	.187	4.8	.375	9.5	1/4"	Male only
FT4-MM*	.187	4.8	.375	9.5	1/4"	Male-Male
FT4-MF*	.187	4.8	.375	9.5	1/4"	Male-Female
FT8-F*	.375	9.5	.75	19.0	1/2"	Female only
FT8-FF*	.375	9.5	.75	19.0	1/2"	Female-Female
FT8-M*	.375	9.5	.75	19.0	1/2"	Male only
FT8-MM*	.375	9.5	.75	19.0	1/2"	Male-Male
FT8-MF*	.375	9.5	.75	19.0	1/2"	Male-Female

* Specify length in inches.

Trimnable Sheath RTD Assembly



Trimnable RTDs provide versatility, accuracy and ease of use in one rugged unit, with a 4-wire lead configuration that provides measurements of the highest precision. The trimmable RTD's easy, cut-to-fit feature allows the user to alter the length of the RTD sheath to fit into various thermowells, pipewells and tubewells. The stainless steel sheath is trimmable, using a commercially available tube cutter, down to a length of 6" (15.2cm).

The leadwire is constructed of 24 AWG Teflon®-insulated, stranded wire, color coded Red/Red White/White. The platinum 100 ohm element complies with DIN 43760, and IEC 751, Class B tolerance.

- High accuracy
- Stock a single sensor for various applications
- Fast delivery
- 100 ohm Platinum RTD Sensor
- Maximum service temperature: 400° F (204° C)
- Available Lengths:
 - Minimum Sheath Length – 6" (15.2cm)
 - Maximum Sheath Length – 60" (152.4cm)
 - Maximum Leadwire Length – 240" (61m)

To order, specify the leadwire length in inches, followed by the sheath length in inches.

Example: RTD43W4-SS25-TR(120")-24"

Roll Temp Assemblies

Conax Roll Temp Sensor Assemblies provide repeatable monitoring of surface temperatures on drums, rollers or other moving surfaces. They are ideal for detecting temperature variations in continuous process applications, such as plastic-film processing, wire manufacturing and painting processes.

Compact and easy to install, Roll Temp Assemblies are furnished with Conax B2 terminal heads. Brass contact buttons, flush-mounted in a spring-loaded Teflon plunger, provide excellent thermal transfer to the temperature sensor. They are available in all base metal thermocouple calibrations. Three models are offered.

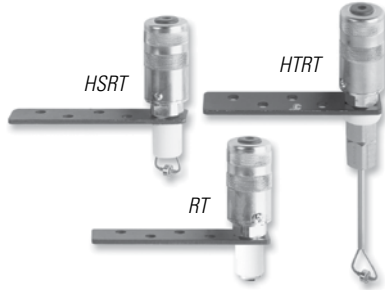

SLIDING CONTACT ASSEMBLY – CATALOG TYPE RT

- Designed for temperature sensing on surface speeds up to 900 ft. per minute
- Temperature range: -90° F to +500° F (-68° C to +260° C).
- .516lb (2.2N) spring force on sensor
- Not available in special tolerances

Example: For a Chromel-Constantan thermocouple, the catalog number would be RT-E.

HIGH-SPEED ASSEMBLY – CATALOG TYPE HSRT

- Features a mounted roller bearing for surface speeds up to 1000 ft. per minute or use on highly polished surfaces that might be damaged by a sliding contact
- Bearing outer race is in contact with the process and the inner race is in intimate contact with the sensor hot junction
- Optional sterling silver roller is available for fast response at slower speeds
- Temperature range: -90° F to +400° F (-68° C to +204° C)
- Not available in dual or triple configurations or in special tolerances

Example: For an Iron-Constantan thermocouple, the catalog number would be HSRT-J.

HIGH-TEMPERATURE ASSEMBLY – CATALOG TYPE HTRT

- Temperature range: -90° F to +700° F (-68° C to +371° C)
- Similar in construction to Type HSRT except that continuous surface contact is assured by use of a Conax spring-loaded compression seal assembly
- Speeds up to 1000 ft./min.
- Available in all base metal calibrations
- Not available in dual or triple configurations or in special tolerances

Example: For a Chromel-Alumel thermocouple, the catalog number would be HTRT-K.

Note: Due to factors of friction and dynamic properties of the environment, these sensors may not conform to ANSI/ASTM published tolerances. Mounting bracket dimensions: 4.5" x 1.0" x .125" with four 0.250" diameter mounting holes over a 2.50" length.

Teflon-Coated Probe Assembly

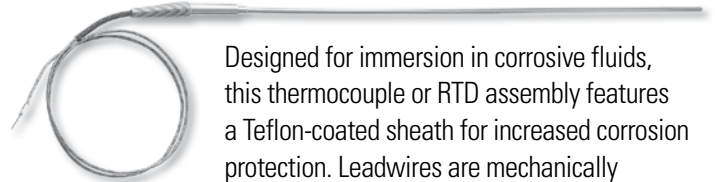

Designed for immersion in corrosive fluids, this thermocouple or RTD assembly features a Teflon-coated sheath for increased corrosion protection. Leadwires are mechanically protected by a stainless steel braid (T4). The assembly is normally terminated with a Conax PJ male plug. Teflon coating can be applied to most sensor probe assemblies presented in this catalog.

Conax Con-O-Clad® Bulk Thermocouple Wire



Conax Technologies manufactures our exclusive mineral insulated (MgO) Con-O-Clad® bulk material for single and multiple pair wires. This is available in all ASTM base metal thermocouple calibrations in sizes from 0.040" (1.016mm) to 0.375" (9.52mm) diameters. Other non-standard material combinations can be furnished for special requirements.

Pipe Clamp Thermocouples

Conax stainless steel pipe clamp assemblies assist in obtaining accurate readings of outside pipe temperatures. They can be used wherever direct immersion probes are impractical or undesirable or where extreme corrosion is a problem.

- Outside application leaves high-pressure lines unbroken
- Easily installed - simply place the opened clamp around the pipe, slip the band end into the worm-gear housing and tighten with a screwdriver.



PIPE CLAMP/SHEATHED THERMOCOUPLE

The catalog number for a pipe clamp/sheathed thermocouple with a terminal head is indicated by placing the pipe clamp catalog number immediately after the terminal head designation. For example, an adjustable pipe clamp thermocouple with a 0.125" (3.18mm) diameter 304SS sheath, using an Iron-Constantan grounded junction thermocouple 18" (457mm) long and terminated with a B2 head for a 2" (50.8mm) pipe would have this catalog number:

Example: J-SS12-G-B2-CL40-18.00"



PIPE CLAMP/WIRE THERMOCOUPLE

Pipe clamp thermocouples are also available in an alternative design consisting of a clamp with 20 gauge thermocouple wire (Types J, K, E & T) and a spring vibration dampener. Standard wire length is 18.00" (457mm). Longer lengths are available. To order this assembly, indicate the pipe clamp catalog number, followed by the calibration and optional wire length if applicable (if nothing is indicated, 18" (457mm) standard will be supplied).

**Examples: CL-10-J
CL-10-J-36.00"**

PIPE CLAMP THERMOCOUPLE SPECIFICATIONS

Catalog Number	Nominal Pipe Sizes (NPT)	Minimum I.D.	
		IN	MM
CL-10	3/8", 1/2", 3/4"	.625	15.9
CL-16	1/2", 3/4", 1"	.812	20.6
CL-24	1", 1-1/4", 1-1/2"	.687	17.5
CL-40	2", 2-1/2"	2.062	52.4
CL-52	2-1/2", 3"	2.812	71.4
CL-64	3-1/2", 4"	3.562	90.5
CL-88	5"	5.062	128.6
CL-104	6"	6.602	154.0

Wall Mount Temperature Sensor

Provides accurate measurement of room air temperature. Available with sensor probe only or with 4-20ma programmable transmitter.



Wall Mount

Armored Assemblies

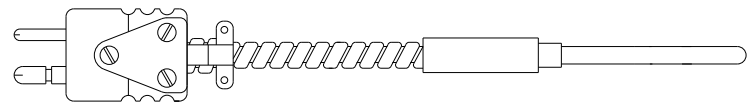

Sensor assemblies can be provided with helically wound stainless steel interlocked armor cable for exceptional mechanical strength, flexibility and RFI/EMI resistance. One of our more popular models consists of a T3 assembly terminated with a Conax PJ male plug. This assembly is ideal for rugged service in physically demanding environments where the leadwires could be exposed to compression and wire abrasion.

Example: J-SS12-G-T3(ARM 20FT)-PJC-12.00"

RTD & Thermocouple Assemblies for Hazardous Locations



CBT 100, CBT 200 and CBT 300 Series assemblies meet U.S. and Canadian standards (NRTL/C, CSA) for use in hazardous locations as defined by NEC Class 1, Division 1, Groups B, C & D; Class II, Groups E, F & G; and Class III.

CBT 100 Series sensor-terminal head assemblies are available in all thermocouple calibrations and in RTD assemblies with 100, 200, 500 and 1000 ohm platinum, 10 ohm copper or 120 ohm nickel elements. Assemblies are available with stainless steel or Inconel sheaths, a W8 mounting fitting and explosion-proof terminal head with terminal strip. An optional 4-20mA transmitter can be provided.

CBT 200 and **CBT 300** assemblies are NEC-compliant replacement probes for use with UL and CSA-approved terminal heads in hazardous locations. CBT 200 provides a W8 fitting for attachment to the terminal head and to the vessel.

CBT 300 provides a W7 fitting for attachment to the terminal head. A separate adjustable fitting is required to attach the probe to the vessel.

CT 600 Series sensor-terminal head assemblies are available in all thermocouple calibrations and in RTD assemblies with 100, 200, 500, and 1000 ohm platinum, 10 ohm copper or 120 ohm nickel elements. Assemblies are available with stainless steel or Inconel sheaths, a spring loaded mounting fitting (CSLW) and explosion-proof terminal head with terminal strip. Note: Sensor must be installed into either a thermowell or a port machined into a solid metal piece with a 1/2-14 NPT mounting connection made per ANSI/ASME B1.20.1 and gauged to + 1/2 to +2 turns from flush with end of start thread in accordance with CSA Std. C22.2 0.5 and UL Std. 1203, A 36" maximum bore depth, a 0.104" minimum wall, and a 0.302" maximum bore.

Certificate No. LR111664-1

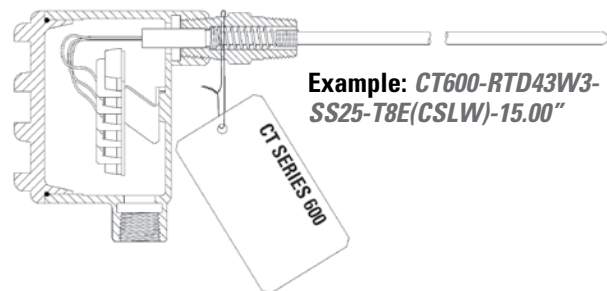
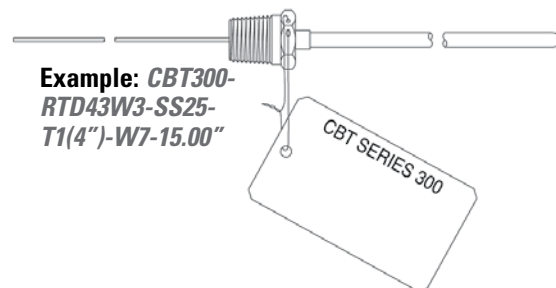
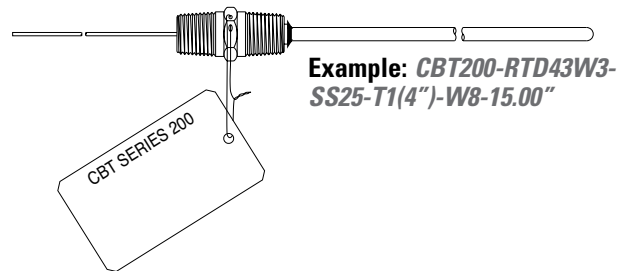
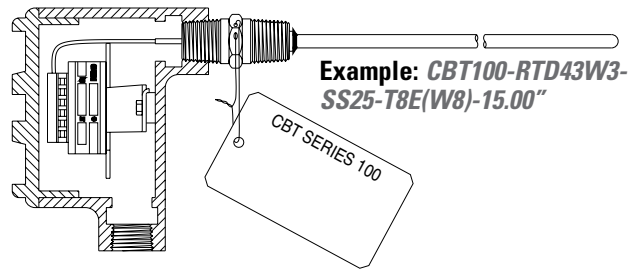

Safety Well Thermocouple Assemblies

Conax WTG and XTG thermocouple assemblies employ a Conax Instrumentation Wire Feedthrough (TG) as the component part for sealing sensor thermocouple wires and the primary environment seal. The seal prevents contamination of the electronics within the terminal head and leakage of gas or liquid into the control room.

- WTG – Grounded Junction
- XTG – Bare Wire Junction

Assemblies consist of base metal thermocouple wire (Types E, J, T and K) surrounded by hard-fired alumina insulators. Use of hard-fired insulators eliminates low IR problems often found in MgO mineral insulated wire junctions. Exposed junction thermocouples offer excellent temperature measurement speed of response.

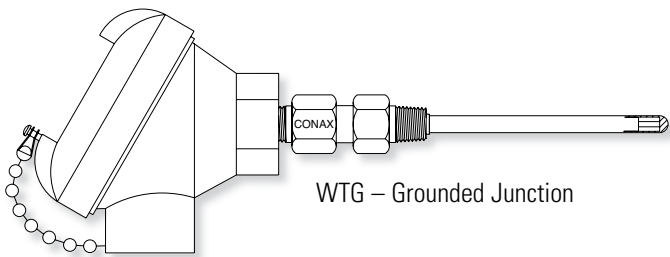

WTG – Grounded Junction

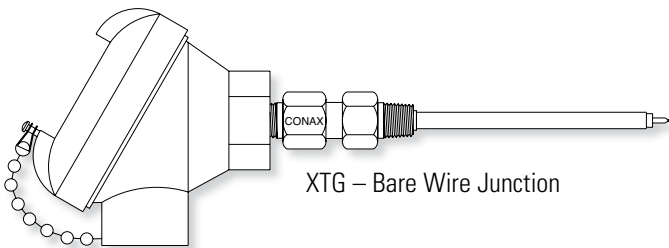

XTG – Bare Wire Junction

The Conax TG compression seal feedthrough uses Conax-designed “soft sealant” technology to seal on the bare wires. It is available with Lava, Teflon, Neoprene or Viton sealant materials. Selection of the proper sealant is dependent on the application. For details, request the Conax Compression Seal Feedthroughs and Fittings catalog #5001 or contact a Conax sales engineer. The protection tube is welded to the compression seal body on the mounting thread side. The other end of the compression seal is attached to the terminal head.

SPECIFICATIONS

Catalog Number	Tube Diameter		NPT IN	Wire Gauge
	IN	MM		
WTG-24	.187	4.76	1/4	24
WTG-20	.250	6.35	1/4	20
WTG-14	.375	9.52	1/2	14
WTG-8	.625	15.87	3/4	8
XTG-20	.250	6.35	1/4	20
XTG-14	.375	9.52	1/2	14
XTG-8	.625	15.87	3/4	8

Catalog Numbering Examples:

WTG-20-B2-L-J-T5CI-12.00"

XTG-14-B4-L-K-T8-14.00"

(For assistance in developing catalog numbers, refer to the Conax Compression Seal Feedthroughs and Fittings catalog #5001 or call a Conax sales engineer.)

Weld Pads

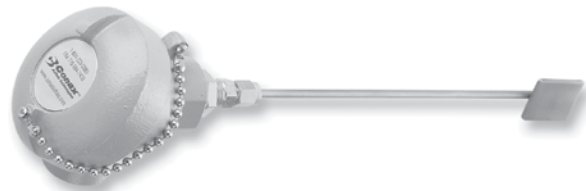

To facilitate welding thermocouples to surfaces in the field, Conax Technologies can fit the measuring junction with a weld pad. Flat or curved pads are 0.125" (3.175mm) thick x 1.00" (25.4mm) square and are available in 304 or optional 316 stainless steel. Flat pads may be welded flat (Style F) or perpendicular (Style P). Curved pads may also be welded flat (FC) or perpendicular (PC) and offer a choice of radius of 0.567" (14.4mm) (for 1" (25.4mm) nominal pipe) or 0.875" (22.2mm) (for 1.5" (38.1mm) nominal pipe).

High Density Feedthrough Assemblies



Conax High Density Feedthrough (HD) assemblies consist of a stainless steel tube swaged over 12, 24, 40 or 60 bundled Teflon-coated thermocouple grade and/or copper wires, providing a continuous wire feedthrough for thermocouples, RTDs or low voltage instrumentation. No epoxy or potting is used in the construction. The assembly can be furnished with or without junctions and comes standard with 24 inches of leadwire on each end. Longer wire lengths can be supplied as required. A single high density feedthrough can pass through a Conax Compression Seal Fitting (PG) for environmental sealing. Greater density through a single port can be achieved by using a Conax Multi-hole Metal Fitting (MHM) that accommodates multiple HD assemblies.

- HD18 - 0.187" (4.75mm) diameter, 12 conductors
- HD25 - 0.250" (6.35mm) diameter, 24 conductors
- HD31 - 0.312" (7.92mm) diameter, 40 conductors
- HD37 - 0.375" (9.52mm) diameter, 60 conductors

- Sheath Material: 300 Series SST, 4.5" nominal length
- Temperature Range: -112° F to +250° F (-80° to +120° C)
- Vacuum Rating: 5 x 10⁻⁶ mm HG @ 68° F (20° C)
- Leak Rate: 1 x 10⁻⁹ scc/sec He @ 68° F (20° C), 1 atm. applied
- Voltage Rating: 100 VDC
- Amperage Rating: 500mA
- Feedthrough Pressure Rating @ 68° F (20° C): 5000 psi (345 bar)

CATALOG NUMBERING SYSTEM:

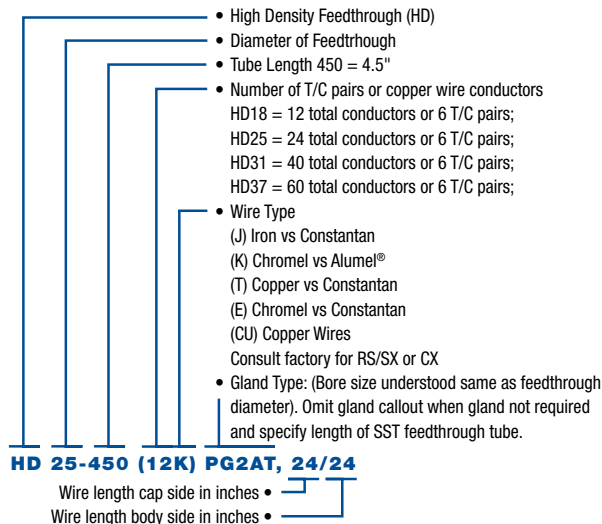

Conax Instrumentation Wire Feedthrough (TG) with 24 AWG Insulated Leadwire

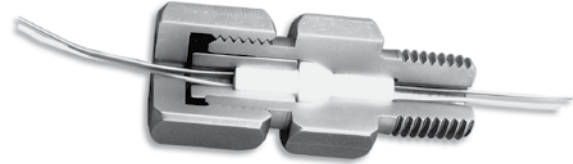

This assembly consists of a Conax Technologies manufactured instrumentation wire feedthrough (TG) with a Teflon or Grafoil sealant and Teflon-coated thermocouple grade or copper wires. Typical applications include the sealing of wires exiting compressor bearing housings, pressure vessels, instruments, furnaces and reactors. The compression seal is furnished with 24" (61cm) of wire on each side. Longer wire lengths can be furnished as required.

Temperature Range: -300° to +450° F (-184° to +232° C)
Pressure Rating @ 68° F (20° C): Vacuum to 4400 psi (300 bar)

CATALOG NUMBERING SYSTEM:

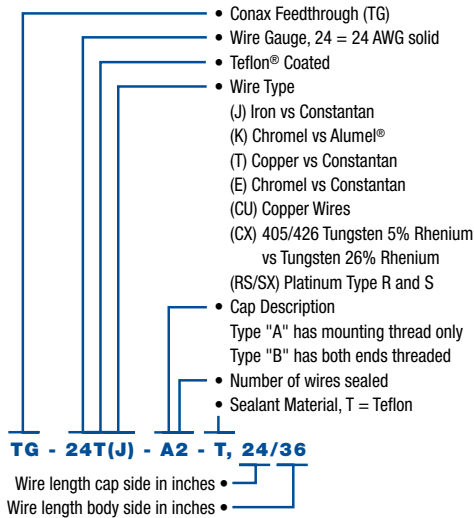

Catalog Number	Mounting Thread IN	PRESSURE RATING @ 68°F (20°C) (PSI)			
		Teflon Sealant PSI	Teflon Sealant BAR	Grafoil Sealant PSI	Grafoil Sealant BAR
MTG-24T(X)-*2	.125	3200	220	4800	331
MTG-24T(X)-*4	.125	3200	220	4800	331
TG-24T(X)-*2	.25	4400	303	7600	524
TG-24T(X)-*4	.25	4400	303	7600	524
TG-24T(X)-*6	.50	3200	220	8000	551
TG-24T(X)-*8	.50	3200	220	8000	551
TG-24T(X)-*12	.75	3200	220	6000	413
TG-24T(X)-*16	.75	3200	220	6000	413
TG-24T(X)-*24	.75	1200	82	2800	193

* Specify Type "A" or "B"

Conax Instrumentation Wire Feedthrough (TGF/TGM) with High Temperature Wires

Conax Compression Seal Feedthrough assemblies with fiberglass-insulated thermo-couple wire are specially designed for applications where the sensor wire is exposed to process temperatures reaching up to 900°F (482°C). This assembly is particularly targeted for use with vacuum and/or inert gas back-filled furnaces with vessel wall temperatures up to 200°F (93°C) and pressures not exceeding 300 psi. The assembly consists of bonded fiberglass-insulated/silicone impregnated thermocouple grade wires on the body side, with stripped bare wires passing through the Conax TGF/TGM Compression Seal Feedthrough. An alternative high-temperature fiberglass for Type K wire is also available with temperature capabilities up to 1400°F (760°C). Sleeved insulation material on the wires exiting the cap side may be fiberglass/silicone impregnated, Teflon® or polyolefin. Available sealant materials are Viton® and Teflon.

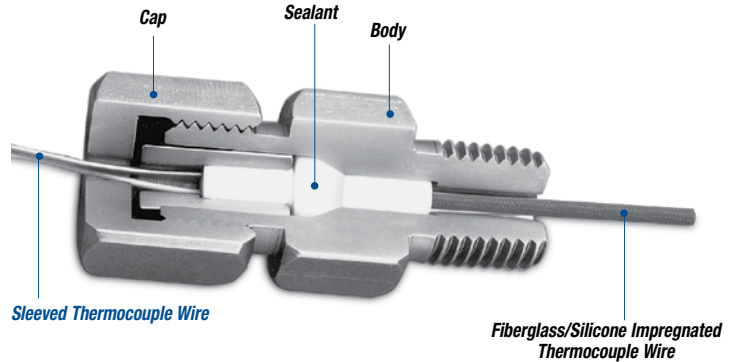

Catalog Number	Wire Gauge	Number of Wires	Thread NPT IN	Length				Hex Size		Pressure Rating**	
				IN	MM	IN	MM	IN	MM	PSIG	BAR
MTG-24F(x)-*2	24	2	1/8	1.375	28.6	1.750	44.5	0.562		300	21
TG-24F(x)-*2	24	2	1/4	2.000	50.8	2.625	66.7	0.750	14.3	300	21
MTG-24F(x)-*4	24	4	1/8	1.375	28.6	1.750	44.5	0.562	19.1	300	21
TG-24F(x)-*4	24	4	1/4	2.000	50.8	2.625	66.7	0.750	14.3	300	21
MTG-20F(x)-*2	20	2	1/8	1.375	28.6	1.750	44.5	0.562	19.1	300	21
TG-20F(x)-*2	20	2	1/4	2.000	50.8	2.625	66.7	0.750	14.3	300	21
MTG-20F(x)-*4	20	4	1/8	1.375	28.6	1.750	44.5	0.562	19.1	300	21
TG-20F(x)-*4	20	4	1/4	2.000	50.8	2.625	66.7	0.750	14.5	300	21
TG-20F(x)-*6	20	6	1/2	2.625	66.7	3.375	85.7	1.000	25.4	300	21
TG-20F(x)-*8	20	8	1/2	2.625	66.7	3.375	85.7	1.000	25.4	300	21
TG-20F(x)-*16	20	16	3/4	2.875	66.7	3.625	85.7	1.250	31.8	300	21

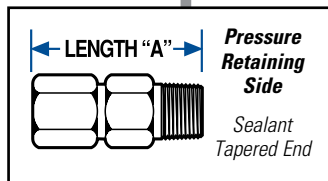

Type A has mounting thread only.

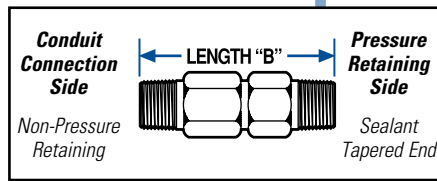

Type B has cap end threaded.

CATALOG NUMBERING SYSTEM:

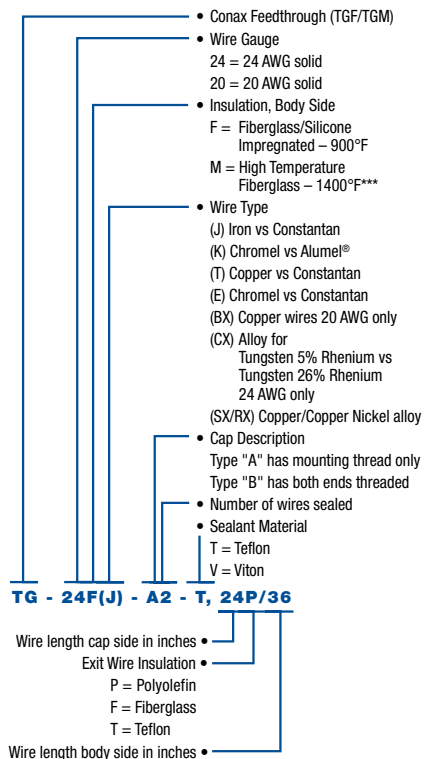

NOTE:

— Other size NPT, MS 33656 Style E mounting thread, and sealing gland materials of construction are available. Consult factory.

* Specify Type "A" or "B"

** Pressure rating guide values are for glands with elements restrained by compressed sealant.

*** Magnesia alumina silicate vitreous fiber braid, modified polyester impregnated, continuous operating temperature to 1400°F (760°C), Type K, 20 AWG only.

CONTACT INFORMATION:

COMPANY:	
NAME:	
TITLE:	
PHONE:	
EMAIL:	

PROCESS CONDITIONS:

TAG NUMBER:			
FLUID MEDIA:			
FLUID STATE:	<input type="checkbox"/> GAS	<input type="checkbox"/> FLUID	<input type="checkbox"/> TWO PHASE
FLUID DENSITY:		<input type="checkbox"/> lbs/ft	<input type="checkbox"/> °C
FLUID VISCOSITY:		<input type="checkbox"/> lbm/ft-sec	<input type="checkbox"/> cP
VELOCITY:	(OPERATING)	(DESIGN)	<input type="checkbox"/> ft/sec <input type="checkbox"/> m/sec
TEMPERATURE:	(OPERATING)	(DESIGN)	<input type="checkbox"/> °F <input type="checkbox"/> °C
PRESSURE:	(OPERATING)	(DESIGN)	<input type="checkbox"/> PSI <input type="checkbox"/> MPo

THERMOWELL (TW) DETAILS:

TW MATERIAL:					
TW TYPE/STYLE:	<input type="checkbox"/> TAPERED	<input type="checkbox"/> STEP-SHANK	<input type="checkbox"/> STRAIGHT	<input type="checkbox"/> PIPEWELL	<input type="checkbox"/> OTHER (SPECIFY)
MOUNTING METHOD:	<input type="checkbox"/> THREADED	<input type="checkbox"/> SOCKET WELD	<input type="checkbox"/> FLANGE	<input type="checkbox"/> WELD-IN	<input type="checkbox"/> OTHER (SPECIFY)
TW CATALOG DESCRIPTION:	(EXAMPLE: .50-260S-U7.50-S316,T=3.50")				
TW DIMENSIONS:	<input type="checkbox"/> PER CATALOG DESCRIPTION (STD)	<input type="checkbox"/> PER TSBL 1	<input type="checkbox"/> PER SUBMITTED DRAWING	<input type="checkbox"/> AS REQUIRED TO PASS ANALYSIS	<input type="checkbox"/> OTHER
UNSUPPORTED LENGTH:	SPECIFY UNSUPPORTED MOUNTING LENGTH (DIM L) PER FIGURE 1A-1C BELOW:			DIM L =	<input type="checkbox"/> in <input type="checkbox"/> mm
IS TW SHIELDED FROM FLOW?	<input type="checkbox"/> NO	<input type="checkbox"/> YES	IF YES SPECIFY DIM Lo VALUE PER FIGURE 1C BELOW:		DIM Lo = <input type="checkbox"/> in <input type="checkbox"/> mm
IS SENSOR INSTALLED?	<input type="checkbox"/> NO	<input type="checkbox"/> YES (DEFAULT)			

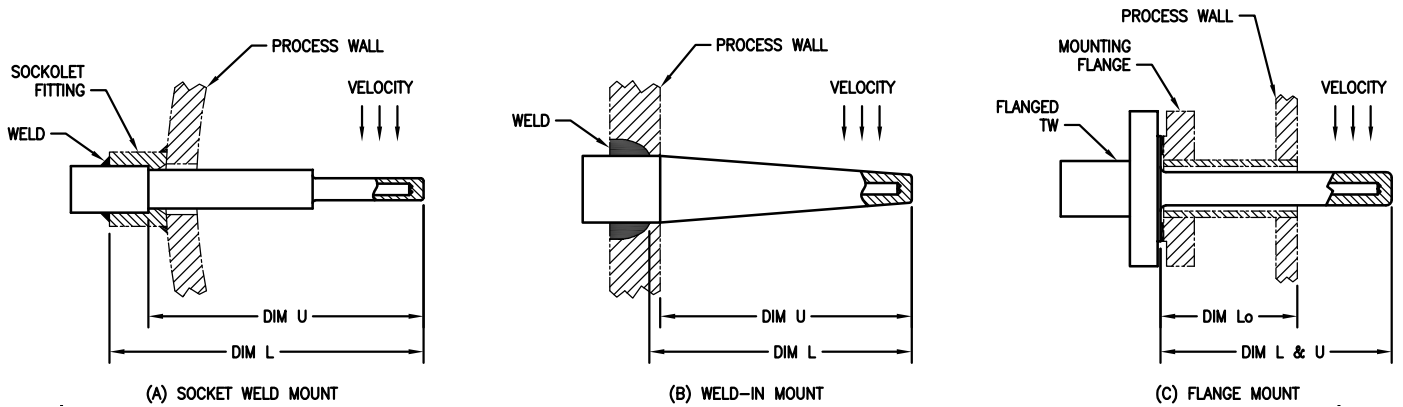
FIGURE 1: VARIOUS THERMOWELL MOUNTING EXAMPLES

TABLE 1: TW DIMENSIONAL VALUES (REFERENCE FIGURES 2A-2D)

UNITS OF MEASURE: in mm

OUTSIDE DIAMETER AT SUPPORTPLANE (ϕA):

OUTSIDE DIAMETER AT TIP (ϕB):

FILLET RADIUS AT SUPPORT PLANE (R_b):

FILLET RADIUS AT STEP-SHANK (R_{bs}):

BORE DIAMETER (ϕd):

TW INSERTION LENGTH (DIM U):

LENGTH OF REDUCED SHANK (DIM Ls):

TIP THICKNESS (DIM T):

NOTES:

- THE INTENTION OF THIS FORM IS TO CAPTURE/IDENTIFY CRITICAL INFORMATION THAT IS DIRECTLY RELEVANT TOWARDS PERFORMING THE WAKE FREQUENCY ANALYSIS PER ASME PTC 19.3 TW-2010 CODE REQUIREMENTS. THIS FORM IS NOT INTENDED TO BE AN ORDERING FORM TO IDENTIFY ALL THERMOWELL DIMENSIONAL DETAILS SUCH AS MOUNTING THREAD SIZES, SOCKET WELD DIAMETERS, LAGGING DIMENSIONS, ETC, WHICH ARE NOT RELEVANT TOWARDS PERFORMING THE WAKE FREQUENCY ANALYSIS.
- SOME TW CONFIGURATIONS AND APPLICATIONS MAY FALL OUTSIDE THE SCOPE OF THE ASME 19.3 TW-2010 CODE.
- TW'S MANUFACTURED FROM PIPE OR WITH SPECIALLY DESIGNED SURFACE STRUCTURES (i.e., KNURLED SURFACES OR WITH SPIRAL RIDGES) FALL OUTSIDE THE SCOPE OF THE ASME PTC 19.3 TW-2010 CODE.

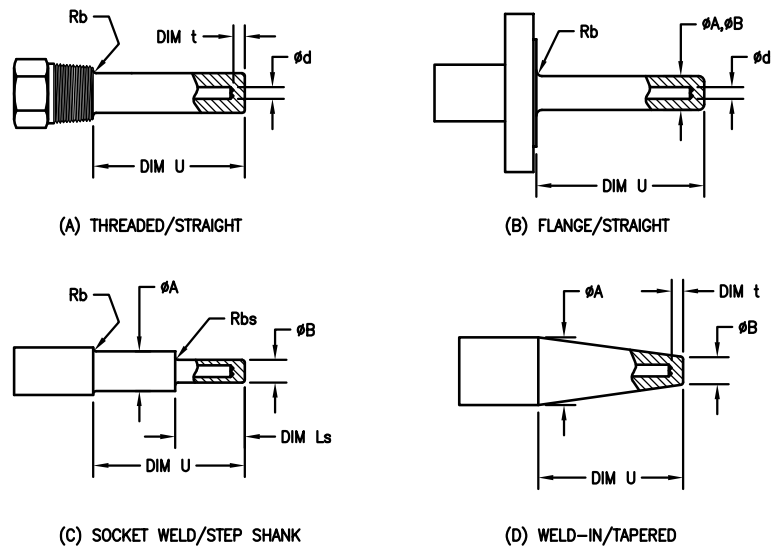
FIGURE 2: THERMOWELL DIMENSIONAL FEATURES FOR VARIOUS CONFIGURATIONS

Temperature Versus Resistance-100ΩRTD $\alpha=0.003850\Omega/\Omega/^{\circ}\text{C}$

°C	0	-1	-2	-3	-4	-5	-6	-7	-8	-9	-10
-200	18.52										
-190	22.83	22.40	21.97	21.54	21.11	20.68	20.25	19.82	19.38	18.95	18.52
-180	27.10	26.67	26.24	25.82	25.39	24.97	24.54	24.11	23.68	23.25	22.83
-170	31.34	30.91	30.49	30.07	29.64	29.22	28.80	28.37	27.95	27.52	27.10
-160	35.54	35.12	34.70	34.28	33.86	33.44	33.02	32.60	32.18	31.76	31.34
-150	39.72	39.31	38.89	38.47	38.05	37.64	37.22	36.80	36.38	35.96	35.54
-140	43.88	43.46	43.05	42.63	42.22	41.80	41.39	40.97	40.56	40.14	39.72
-130	48.00	47.59	47.18	46.77	46.36	45.94	45.53	45.12	44.70	44.29	43.88
-120	52.11	51.70	51.29	50.88	50.47	50.06	49.65	49.24	48.83	48.42	48.00
-110	56.19	55.79	55.38	54.97	54.56	54.15	53.75	53.34	52.93	52.52	52.11
-100	60.26	59.85	59.44	59.04	58.63	58.23	57.82	57.41	57.01	56.60	56.19
-90	64.30	63.90	63.49	63.09	62.68	62.28	61.88	61.47	61.07	60.66	60.26
-80	68.33	67.92	67.52	67.12	66.72	66.31	65.91	65.51	65.11	64.70	64.30
-70	72.33	71.93	71.53	71.13	70.73	70.33	69.93	69.53	69.13	68.73	68.33
-60	76.33	75.93	75.53	75.13	74.73	74.33	73.93	73.53	73.13	72.73	72.33
-50	80.31	79.91	79.51	79.11	78.72	78.32	77.92	77.52	77.12	76.73	76.33
-40	84.27	83.87	83.48	83.08	82.69	82.29	81.89	81.50	81.10	80.70	80.31
-30	88.22	87.83	87.43	87.04	86.64	86.25	85.85	85.46	85.06	84.67	84.27
-20	92.16	91.77	91.37	90.98	90.59	90.19	89.80	89.40	89.01	88.62	88.22
-10	96.09	95.69	95.30	94.91	94.52	94.12	93.73	93.34	92.95	92.55	92.16
0	100.00	99.61	99.22	98.83	98.44	98.04	97.65	97.26	96.87	96.48	96.09
°C	0	1	2	3	4	5	6	7	8	9	10
0	100.00	100.39	100.78	101.17	101.56	101.95	102.34	102.73	103.12	103.51	103.90
10	103.90	104.29	104.68	105.07	105.46	105.85	106.24	106.63	107.02	107.40	107.79
20	107.79	108.18	108.57	108.96	109.35	109.73	110.12	110.51	110.90	111.29	111.67
30	111.67	112.06	112.45	112.83	113.22	113.61	114.00	114.38	114.77	115.15	115.54
40	115.54	115.93	116.31	116.70	117.08	117.47	117.86	118.24	118.63	119.01	119.40
50	119.40	119.78	120.17	120.55	120.94	121.32	121.71	122.09	122.47	122.86	123.24
60	123.24	123.63	124.01	124.39	124.78	125.16	125.54	125.93	126.31	126.69	127.08
70	127.08	127.46	127.84	128.22	128.61	128.99	129.37	129.75	130.13	130.52	130.90
80	130.90	131.28	131.66	132.04	132.42	132.80	133.18	133.57	133.95	134.33	134.71
90	134.71	135.09	135.47	135.85	136.23	136.61	136.99	137.37	137.75	138.13	138.51
100	138.51	138.88	139.26	139.64	140.02	140.40	140.78	141.16	141.54	141.91	142.29
110	142.29	142.67	143.05	143.43	143.80	144.18	144.56	144.94	145.31	145.69	146.07
120	146.07	146.44	146.82	147.20	147.57	147.95	148.33	148.70	149.08	149.46	149.83
130	149.83	150.21	150.58	150.96	151.33	151.71	152.08	152.46	152.83	153.21	153.58
140	153.58	153.96	154.33	154.71	155.08	155.46	155.83	156.20	156.58	156.95	157.33
150	157.33	157.70	158.07	158.45	158.82	159.19	159.56	159.94	160.31	160.68	161.05
160	161.05	161.43	161.80	162.17	162.54	162.91	163.29	163.66	164.03	164.40	164.77
170	164.77	165.14	165.51	165.89	166.26	166.63	167.00	167.37	167.74	168.11	168.48
180	168.48	168.85	169.22	169.59	169.96	170.33	170.70	171.07	171.43	171.80	172.17
190	172.17	172.54	172.91	173.28	173.65	174.02	174.38	174.75	175.12	175.49	175.86
200	175.86	176.22	176.59	176.96	177.33	177.69	178.06	178.43	178.79	179.16	179.53

Temperature Versus Resistance-100ΩRTD $\alpha=0.003850\Omega/\Omega/^{\circ}\text{C}$

°C	0	1	2	3	4	5	6	7	8	9	10
210	179.53	179.89	180.26	180.63	180.99	181.36	181.72	182.09	182.46	182.82	183.19
220	183.19	183.55	183.92	184.28	184.65	185.01	185.38	185.74	186.11	186.47	186.84
230	186.84	187.20	187.56	187.93	188.29	188.66	189.02	189.38	189.75	190.11	190.47
240	190.47	190.84	191.20	191.56	191.92	192.29	192.65	193.01	193.37	193.74	194.10
250	194.10	194.46	194.82	195.18	195.55	195.91	196.27	196.63	196.99	197.35	197.71
260	197.71	198.07	198.43	198.79	199.15	199.51	199.87	200.23	200.59	200.95	201.31
270	201.31	201.67	202.03	202.39	202.75	203.11	203.47	203.83	204.19	204.55	204.90
280	204.90	205.26	205.62	205.98	206.34	206.70	207.05	207.41	207.77	208.13	208.48
290	208.48	208.84	209.20	209.56	209.91	210.27	210.63	210.98	211.34	211.70	212.05
300	212.05	212.41	212.76	213.12	213.48	213.83	214.19	214.54	214.90	215.25	215.61
310	215.61	215.96	216.32	216.67	217.03	217.38	217.74	218.09	218.44	218.80	219.15
320	219.15	219.51	219.86	220.21	220.57	220.92	221.27	221.63	221.98	222.33	222.68
330	222.68	223.04	223.39	223.74	224.09	224.45	224.80	225.15	225.50	225.85	226.21
340	226.21	226.56	226.91	227.26	227.61	227.96	228.31	228.66	229.02	229.37	229.72
350	229.72	230.07	230.42	230.77	231.12	231.47	231.82	232.17	232.52	232.87	233.21
360	233.21	233.56	233.91	234.26	234.61	234.96	235.31	235.66	236.00	236.35	236.70
370	236.70	237.05	237.40	237.74	238.09	238.44	238.79	239.13	239.48	239.83	240.18
380	240.18	240.52	240.87	241.22	241.56	241.91	242.26	242.60	242.95	243.29	243.64
390	243.64	243.99	244.33	244.68	245.02	245.37	245.71	246.06	246.40	246.75	247.09
400	247.09	247.44	247.78	248.13	248.47	248.81	249.16	249.50	249.85	250.19	250.53
410	250.53	250.88	251.22	251.56	251.91	252.25	252.59	252.93	253.28	253.62	253.96
420	253.96	254.30	254.65	254.99	255.33	255.67	256.01	256.35	256.70	257.04	257.38
430	257.38	257.72	258.06	258.40	258.74	259.08	259.42	259.76	260.10	260.44	260.78
440	260.78	261.12	261.46	261.80	262.14	262.48	262.82	263.16	263.50	263.84	264.18
450	264.18	264.52	264.86	265.20	265.53	265.87	266.21	266.55	266.89	267.22	267.56
460	267.56	267.90	268.24	268.57	268.91	269.25	269.59	269.92	270.26	270.60	270.93
470	270.93	271.27	271.61	271.94	272.28	272.61	272.95	273.29	273.62	273.96	274.29
480	274.29	274.63	274.96	275.30	275.63	275.97	276.30	276.64	276.97	277.31	277.64
490	277.64	277.98	278.31	278.64	278.98	279.31	279.64	279.98	280.31	280.64	280.98
500	280.98	281.31	281.64	281.98	282.31	282.64	282.97	283.31	283.64	283.97	284.30
510	284.30	284.63	284.97	285.30	285.63	285.96	286.29	286.62	286.95	287.29	287.62
520	287.62	287.95	288.28	288.61	288.94	289.27	289.60	289.93	290.26	290.59	290.92
530	290.92	291.25	291.58	291.91	292.24	292.56	292.89	293.22	293.55	293.88	294.21
540	294.21	294.54	294.86	295.19	295.52	295.85	296.18	296.50	296.83	297.16	297.49
550	297.49	297.81	298.14	298.47	298.80	299.12	299.45	299.78	300.10	300.43	300.75
560	300.75	301.08	301.41	301.73	302.06	302.38	302.71	303.03	303.36	303.69	304.01
570	304.01	304.34	304.66	304.98	305.31	305.63	305.96	306.28	306.61	306.93	307.25
580	307.25	307.58	307.90	308.23	308.55	308.87	309.20	309.52	309.84	310.16	310.49
590	310.49	310.81	311.13	311.45	311.78	312.10	312.42	312.74	313.06	313.39	313.71
600	313.71	314.03	314.35	314.67	314.99	315.31	315.64	315.96	316.28	316.60	316.92
610	316.92	317.24	317.56	317.88	318.20	318.52	318.84	319.16	319.48	319.80	320.12
620	320.12	320.43	320.75	321.07	321.39	321.71	322.03	322.35	322.67	322.98	323.30
630	323.30	323.62	323.94	324.26	324.57	324.89	325.21	325.53	325.84	326.16	326.48
640	326.48	326.79	327.11	327.43	327.74	328.06	328.38	328.69	329.01	329.32	329.64
650	329.64										

Tolerances for a 100Ω Platinum RTD per IEC 751-95

Temperature Degree (C)	Tolerance					
	Class B		1/3 Class B		Class A	
	(±C) ¹	(±0hm)	(±C)	(±0hm)	(±C) ²	(±0hm)
-200	1.30	0.56	1.10	0.48	0.55	0.24
-100	0.80	0.32	0.60	0.24	0.35	0.14
0	0.30	0.12	0.10	0.04	0.15	0.06
100	0.80	0.30	0.60	0.23	0.35	0.13
200	1.30	0.48	1.10	0.40	0.55	0.20
300	1.80	0.64	1.60	0.57	0.75	0.27
400	2.30	0.79	2.10	0.72	0.95	0.33
500	2.80	0.93	2.60	0.87	1.15	0.38
600	3.30	1.06	3.10	1.00	1.35	0.43

Notes: ¹C=±(.3+.005*[t]) ²C=±(.15+.002*[t])

Tolerances for a 100Ω Platinum RTD per ASTM E1137-97

Temperature Degree (C)	Tolerance					
	Class B		1/3 Class B		Class A	
	(±C) ¹	(±0hm)	(±C)	(±0hm)	(±C) ²	(±0hm)
-200	1.1	0.47	0.92	0.38	0.47	0.20
-100	0.67	0.27	0.50	0.20	0.30	0.12
0	0.25	0.10	0.08	0.03	0.13	0.05
100	0.67	0.25	0.50	0.19	0.30	0.11
200	1.1	0.40	0.92	0.34	0.47	0.17
300	1.5	0.54	1.34	0.48	0.64	0.23
400	1.9	0.66	1.76	0.61	0.81	0.28
500	2.4	0.78	2.18	0.73	0.98	0.33
600	2.8	0.88	2.60	0.84	1.15	0.37

Notes: ¹C=±(.25+.0042*[t]) ²C=±(.13+.0017*[t])

Tolerance Values as Function of Temperature for a 100Ω RTD per IEC 751 (1983)

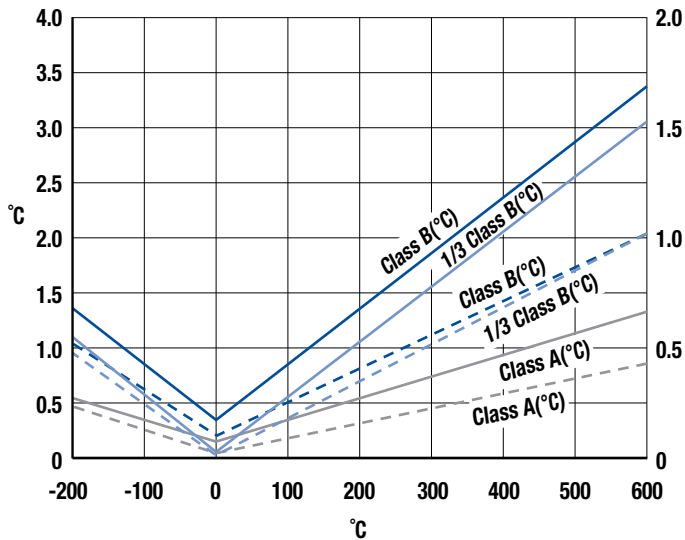

Tolerance Values as Function of Temperature for a 100Ω RTD per ASTM E1137

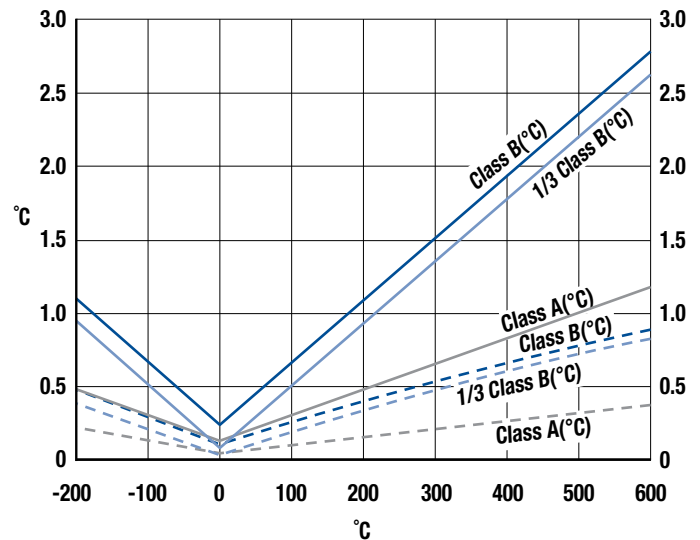

Temperature vs. Resistance – 10Ω Copper

Temperature (°C)	Resistance (ohms)
-70	6.331
-60	6.722
-50	7.111
-40	7.499
-30	7.886
-20	8.272
-10	8.657
0	9.042
10	9.427
20	9.812
30	10.198
40	10.583
50	10.968
60	11.353
70	11.738
80	12.124
90	12.509
100	12.894
110	13.279
120	13.664
130	14.050
140	14.435
150	14.820

Temperature vs. Resistance – 120Ω Nickel

Temperature (°C)	Resistance (ohms)	Temperature (°C)	Resistance (ohms)
-50	86.16	110	209.85
-40	92.76	120	219.29
-30	99.41	130	228.95
-20	106.15	140	238.84
-10	113.00	150	248.95
0	120.00	160	259.30
10	127.17	170	269.89
20	134.52	180	280.77
30	142.06	190	291.95
40	149.80	200	303.45
50	157.75	210	315.31
60	165.90	220	327.54
70	174.27	230	340.14
80	182.85	240	353.14
90	191.64	250	366.53
100	200.64	260	380.31

Temperature vs. Resistance – 10Ω Copper per SAMA RC21-4-1973

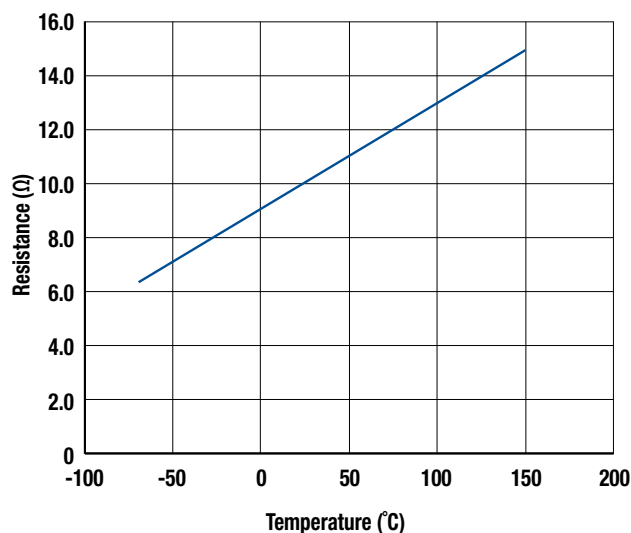

Temperature vs. Resistance – 120Ω Nickel

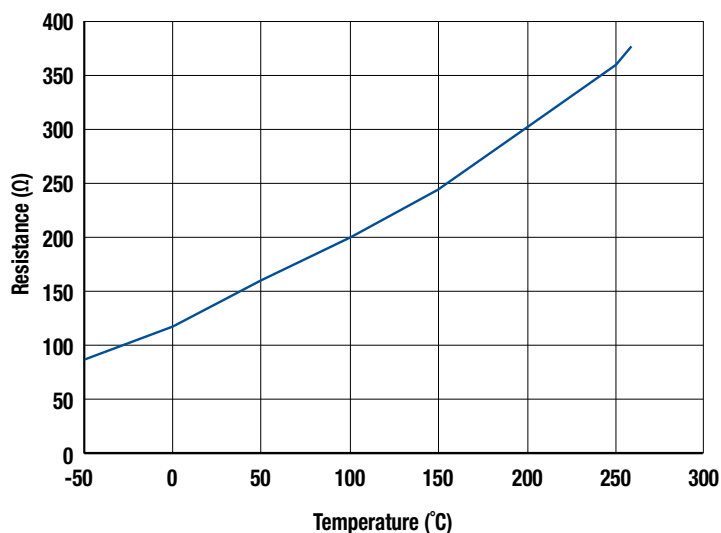

Bridge Network Connections

FIGURE A

Two Wire Resistance Temperature Device

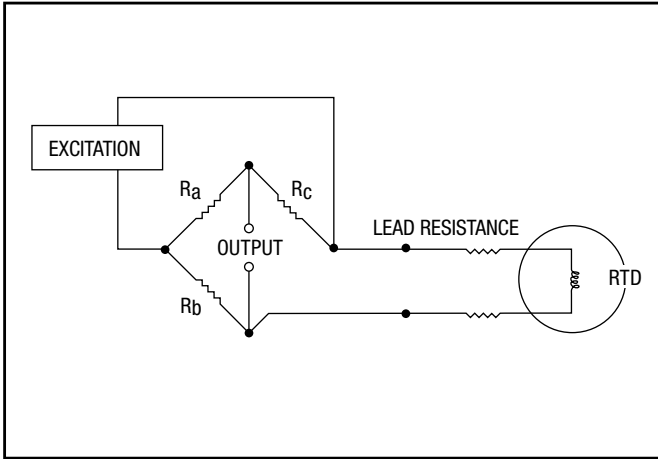

FIGURE C

Four Wire Resistance Temperature Device

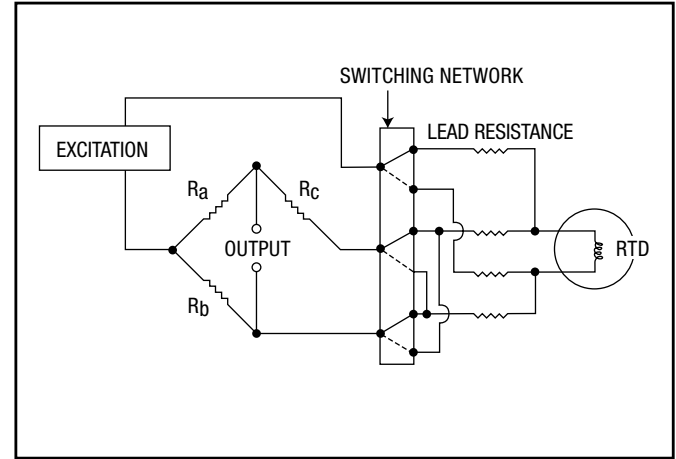

FIGURE B

Three Wire Resistance Temperature Device

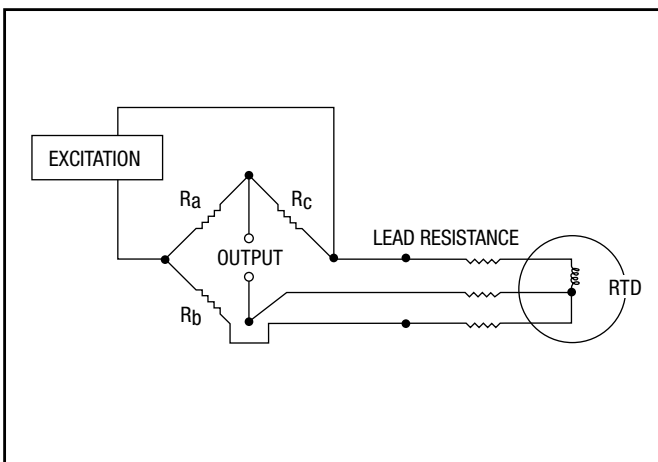
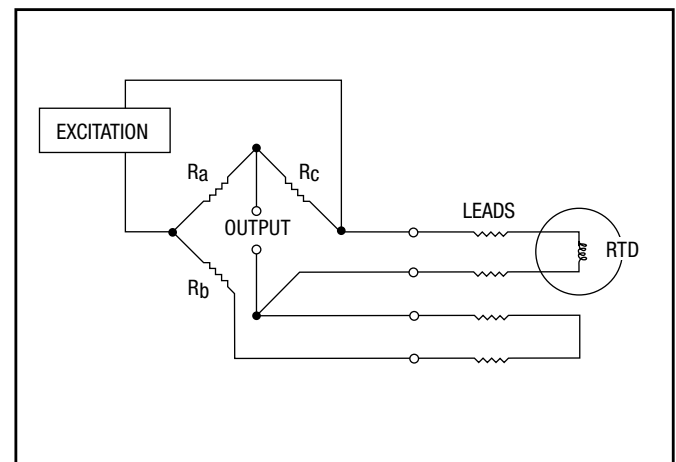

FIGURE D

Four Wire Resistance Temperature Device



Thermocouple Wire Size and Resistance Table

AWG No	Diameter Inches	ISA Type K Chromel/Alumel	ISA Type J Iron/Constantan	ISA Type T Copper/Constantan	ISA Type E Chromel/Constantan	ISA Type N Nicrosil/Nisil	ISA Type S PT-PT 10%RH	ISA Type R PT-PT 13%RH
8	0.128	0.036	0.218	0.018	0.043	0.048	0.011	0.011
12	0.080	0.091	0.053	0.045	0.109	0.122	0.028	0.029
14	0.064	0.146	0.085	0.073	0.175	0.194	0.045	0.047
16	0.050	0.233	0.136	0.117	0.277	0.310	0.071	0.073
18	0.040	0.370	0.218	0.187	0.445	0.492	0.116	0.119
20	0.032	0.589	0.349	0.299	0.703	0.781	0.185	0.190
22	0.025	0.936	0.544	0.475	1.120	1.249		
24	0.020	1.490	0.878	0.752	1.780	1.980	0.464	0.478
26	0.015	2.381	1.405	1.204	2.836	3.164	0.740	0.760
28	0.012	3.768	2.235	1.915	4.512	5.039		
30	0.010	5.984	3.551	3.043	7.169	8.000	1.850	1.910

L1 – Resistance in Ohms per Double Foot at 68° F. For explanation of how to use this table, see Example:

L2 – EXAMPLE: What is the external resistance to my instrument if I use a 20 gauge Chromel/Alumel thermocouple 3 feet long and 14 gauge Chromel/Alumel lead wire 20 feet in length?

L3 – $3 \times .589 = 1.768$ ohms

L4 – $20 \times .146 = 2.932$ ohms

L5 – Total 4.700 ohms

L6 – NOTE: Type S and R utilize extension lead wire type Copper/Copper 11. Type B utilizes extension lead wire type Copper/Copper.

Thermocouple EMF Versus Temperature

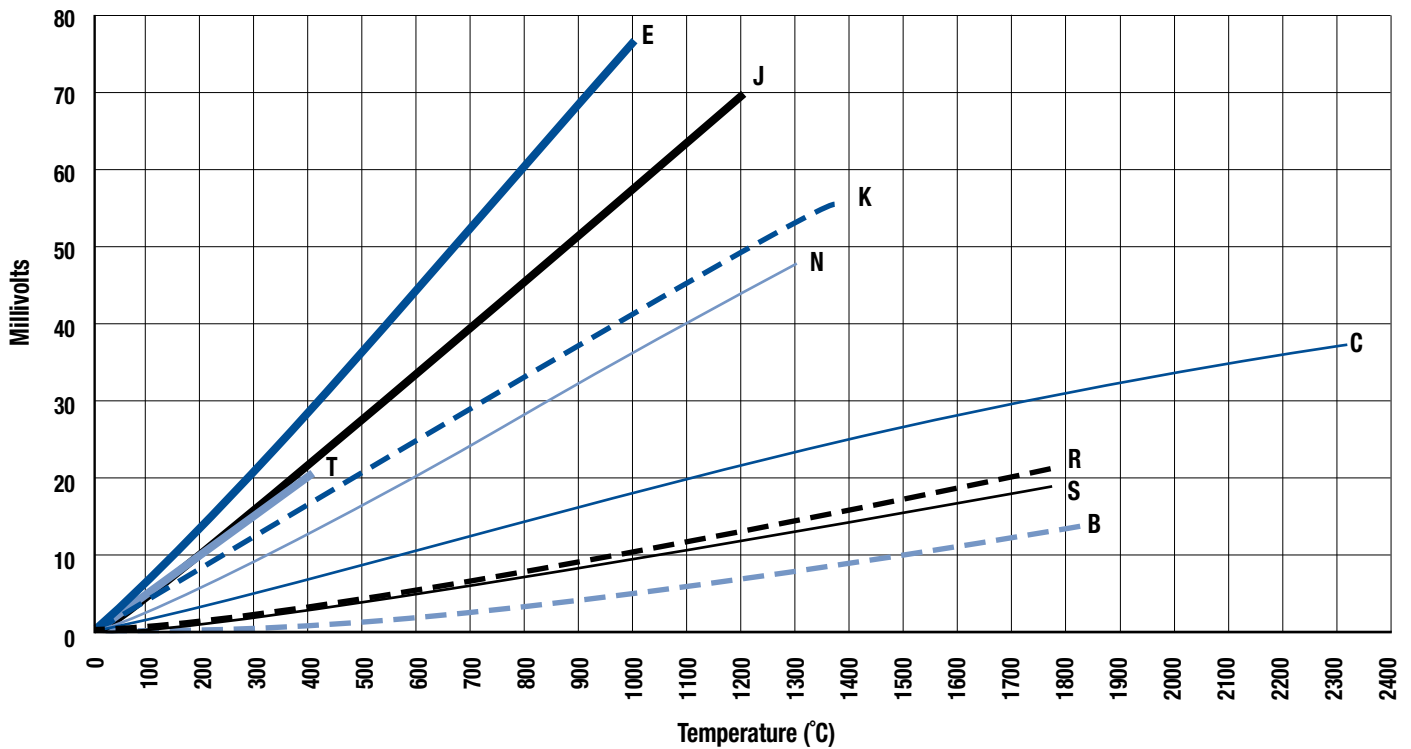

Thermocouple Characteristics Table

ASTM	Symbol Single	Generic Names	Color Coding		Magnetic		Environment (Bare Wire)
			Individual Conductor	Overall Jacket Extension Grade Wire	Yes	No	
T	TP TN	Copper Constantan, Nominal Composition: 55% Cu, 45% Ni	Blue Red	Blue	X X		Mild Oxidizing, Reducing. Vacuum or Inert. Good where moisture is present.
J	JP JN	Iron Constantan, Nominal Composition: 55% Cu, 45% Ni	White Red	Black	X X		Reducing Vacuum, Inert. Limited use in oxidizing at High Temperatures. Not recommended for low temps.
E	EP EN	Chromel®, Nominal Composition: 90% Ni, 10% Cr Constantan, Nominal Composition: 55% Cu, 45% Ni	Purple Red	Purple	X X		Oxidizing or Inert. Limited use in Vacuum or Reducing.
K	KP KN	Chromel, Nominal Composition: 90% Ni, 10% Cr Alumel®, Nominal Composition: 95% Ni, 2% Mn, 2% Al	Yellow Red	Yellow	X X		Clean Oxidizing and Inert. Limited use in Vacuum or Reducing.
N	NP NN	Nicrosil, Nominal Compositions: 84.6% Ni, 14.2% Cr, 1.4% Si Nisil, Nominal Composition: 95.5% Ni, 4.4% Si, 1% Mg	Orange Red	Orange	X X		Clean Oxidizing and Inert. Limited use in Vacuum or Reducing.
S	SP SN	Platinum 10% Rhodium Pure Platinum	Black Red	Green	X X		Oxidizing or Inert Atmospheres. Do not insert in metal tubes. Beware of contamination.
R	RP RN	Platinum 13% Rhodium Pure Platinum	Black Red	Green	X X		Oxidizing or Inert Atmospheres. Do not insert in metal tubes. Beware of contamination.
B	BP BN	Platinum 30% Rhodium Platinum 6% Rhodium	Gray Red	Gray	X X		Oxidizing or Inert Atmospheres. Do not insert in metal tubes. Beware of contamination.
C*	P N	Tungsten 5% Rhenium Tungsten 26% Rhenium	Green Red	Red	X X		Vacuum, Inert, Hydrogen Atmospheres. Beware of Embrittlement.

Thermocouple Extension Wire Characteristics				
T	TP (+) TN (-)	Copper Constantan	Blue Red	Brown
J	JP (+) JN (-)	Iron Constantan	White Red	Brown
E	EP (+) EN (-)	Chromel® Constantan	Purple Red	Brown
K	KP (+) KN (-)	Chromel® Alumel®	Yellow Red	Brown
N	NP (+) NN (-)	Nicrosil Nisil	Orange Red	Brown

*Type C was previously designated as W5.

Tolerance of Thermocouples

ASTM	°C			°F		
	Temperature Range	Standard	Special	Temperature Range	Standard	Special
T	-200° to -67° -67° to -62° -62° to 125° 125° to 133° 133° to 370°	± 1.5% T ± 1° ± 1° ± 1° ± 0.75% T	± 0.8% T* ± 0.8% T* ± 0.5° ± 0.4% T ± 0.4% T	-328° to -88° -88° to -80° -80° to 257° 257° to 272° 272° to 700°	± 1.5% (T-32) ± 1.8° ± 1.8° ± 1.8° ± 0.75% (T-32)	± 0.8% (T-32)* ± 0.8% (T-32)* ± 0.9°* ± 0.4% (T-32) ± 0.4% (T-32)
J	0° to 275° 275° to 293° 293° to 760°	± 2.2° ± 2.2° ± 0.75% T	± 1.1° ± 0.4% T ± 0.4% T	32° to 527° 527° to 560° 560° to 1400°	± 3.96° ± 3.96° ± 0.75% (T-32)	± 1.98° ± 0.4% (T-32) ± 0.4% (T-32)
E	-200° to -170° -170° to 250° 250° to 340° 340° to 870°	± 1% T ± 1.7° ± 1.7° ± 0.5% T	± 1°* ± 1°* ± 0.4% T ± 0.4% T	-328° to -274° -274° to 482° 482° to 644° 644° to 1600°	± 1% (T-32) ± 3.06° ± 3.06° ± 0.5% (T-32)	± 1.8°* ± 1.8°* ± 0.4% (T-32) ± 0.4% (T-32)
K	-200° to -110° -110° to 0° 0° to 275° 275° to 293° 293° to 1260°	± 2% T ± 2.2° ± 2.2° ± 2.2° ± 0.75% T	— — ± 1.1° ± 0.4% T ± 0.4% T	-328° to -166° -166° to 32° 32° to 527° 527° to 560° 560° to 2300°	± 2% (T-32) ± 3.96° ± 3.96° ± 3.96° ± 0.75% (T-32)	— — ± 1.98° ± 0.4% (T-32) ± 0.4% (T-32)
N	0° to 275° 275° to 293° 293° to 1250°	± 2.2° ± 2.2° ± 0.75% T	± 1.1° ± 0.4% T ± 0.4% T	32° to 527° 527° to 560° 560° to 2300°	± 3.96° ± 3.96° ± 0.75% (T-32)	± 1.98° ± 0.4% (T-32) ± 0.4% (T-32)
R or S	0° to 600° 600° to 1480°	± 1.5° ± 0.25% T	± 0.6° ± 0.1% T	32° to 1112° 1112° to 2700°	± 2.7° ± 0.25% (T-32)	± 1.08° ± 0.1% (T-32)
B	870° to 1700°	± 0.5% T	± 0.25% T	1600° to 3100°	± 0.5% (T-32)	± 0.25% (T-32)
C*	0° to 426° 426° to 2315°	± 4.4° ± 1% T	— —	32° to 800° 800° to 4200°	± 8° ± 1% (T-32)	— —
Tolerances of Thermocouple Extension Wire						
TX	-60° to 100°	± 1.0	± 0.5	-75° to 200°	± 1.8	± 0.9
JX	0° to 200°	± 2.2	± 1.1	32° to 400°	± 4.0	± 2.0
EX	0° to 200°	± 1.7	± 1.0	32° to 400°	± 3.0	± 1.8
KX	0° to 200°	± 2.2	± 1.1	32° to 400°	± 4.0	± 2.0
NX	0° to 200°	± 2.2	± 1.1	32° to 400°	± 4.0	± 2.0
SX	0° to 200°	± 5.0	†	32° to 400°	± 9.0	†
RX	0° to 200°	± 5.0	†	32° to 400°	± 9.0	†
BX ¹	0° to 200°	± 4.2	†	32° to 400°	± 7.6	†
B ²	0° to 100°	± 3.7	†	32° to 400°	± 6.7	†
C	0° to 200°	± 0.110 mV	†	32° to 400°	± 0.110 mV	†

¹ Special tolerance grade compensating extension wires are not available.

¹ Proprietary alloy compensating extension wire is available for use over a wide temperature range.

² Special compensating extension wires are not necessary with Type B over the limited temperature range 0 to 50° C (32 to 125° F), where the use of non-compensated (copper/copper) conductors introduces no significant error. For a somewhat larger temperature gradient of 0 to 100° C (32 to 210° F) across the extension portion of the circuit, the use of non-compensated (copper/copper) extension wires may result in small errors, the magnitude of which will not exceed the tolerance values given in the table above for measurements above 100° C (1800° F).

*Special tolerances below 0° C (32° F) are unofficial and are provided as a basis of discussion between Conax and our customers.

Type C was previously designated as W5.

Temperature Conversion Chart

Enter the table in the center column of bold face type marked "Temp" with the temperature either Celsius or Fahrenheit that you wish to convert into the other scale. If converting from Fahrenheit to Celsius, the equivalent temperature will be found in the column to the left, and if converting from Celsius to Fahrenheit, the equivalent temperature will be found in the column to the right.

Celsius=5/9(°F-32) Fahrenheit=9/5(°C)+32 Kelvin=°C+273.15 Rankine=°F+459.67

°C	Temp	°F	°C	Temp	°F	°C	Temp	°F
-17.8	0	32.0	7.8	46	114.8	33.3	92	197.6
-17.2	1	33.8	8.3	47	116.6	33.9	93	199.4
-16.7	2	35.6	8.9	48	118.4	34.4	94	201.2
-16.1	3	37.4	9.4	49	120.2	35.0	95	203.0
-15.6	4	39.2	10.0	50	122.0	35.6	96	204.8
-15.0	5	41.0	10.6	51	123.8	36.1	97	206.6
-14.4	6	42.8	11.1	52	125.6	36.7	98	208.4
-13.9	7	44.6	11.7	53	127.4	37.2	99	210.2
-13.3	8	46.4	12.2	54	129.2	37.8	100	212.0
-12.8	9	48.2	12.8	55	131.0	43.3	110	230.0
-12.2	10	50.0	13.3	56	132.8	48.9	120	248.0
-11.7	11	51.8	13.9	57	134.6	54.4	130	266.0
-11.1	12	53.6	14.4	58	136.4	60.0	140	284.0
-10.6	13	55.4	15.0	59	138.2	65.6	150	302.0
-10.0	14	57.2	15.6	60	140.0	71.1	160	320.0
-9.4	15	59.0	16.1	61	141.8	76.7	170	338.0
-8.9	16	60.8	16.7	62	143.6	82.2	180	356.0
-8.3	17	62.6	17.2	63	145.4	87.8	190	374.0
-7.8	18	64.4	17.8	64	147.2	93.3	200	392.0
-7.2	19	66.2	18.3	65	149.0	98.9	210	410.0
-6.7	20	68.0	18.9	66	150.8	100.0	212	413.6
-6.1	21	69.8	19.4	67	152.6	104.4	220	428.0
-5.6	22	71.6	20.0	68	154.4	110.0	230	446.0
-5.0	23	73.4	20.6	69	156.2	115.6	240	464.0
-4.4	24	75.2	21.1	70	158.0	121.1	250	482.0
-3.9	25	77.0	21.7	71	159.8	126.7	260	500.0
-3.3	26	78.8	22.2	72	161.6	132.2	270	518.0
-2.8	27	80.6	22.8	73	163.4	137.8	280	536.0
-2.2	28	82.4	23.3	74	165.2	143.3	290	554.0
-1.7	29	84.2	23.9	75	167.0	148.9	300	572.0
-1.1	30	86.0	24.4	76	168.8	154.4	310	590.0
-0.6	31	87.8	25.0	77	170.6	160.0	320	608.0
0.0	32	89.6	25.6	78	172.4	165.6	330	626.0
0.6	33	91.4	26.1	79	174.2	171.1	340	644.0
1.1	34	93.2	26.7	80	176.0	176.7	350	662.0
1.7	35	95.0	27.2	81	177.8	182.2	360	680.0
2.2	36	96.8	27.8	82	179.6	187.8	370	698.0
2.8	37	98.6	28.3	83	181.4	193.3	380	716.0
3.3	38	100.4	28.9	84	183.2	198.9	390	734.0
3.9	39	102.2	29.4	85	185.0	204.4	400	752.0
4.4	40	104.0	30.0	86	186.8	210.0	410	770.0
5.0	41	105.8	30.6	87	188.6	215.6	420	788.0
5.6	42	107.6	31.1	88	190.4	221.1	430	806.0
6.1	43	109.4	31.7	89	192.2	226.7	440	824.0
6.7	44	111.2	32.2	90	194.0	232.2	450	842.0
7.2	45	113.0	32.8	91	195.8	237.8	460	860.0

°C	Temp	°F	°C	Temp	°F	°C	Temp	°F
243.3	470	878.0	498.9	930	1706.0	971.1	1780	3236.0
248.9	480	896.0	504.4	940	1724.0	982.2	1800	3272.0
254.4	490	914.0	510.0	950	1742.0	993.3	1820	3308.0
260.0	500	932.0	515.6	960	1760.0	1004.4	1840	3344.0
265.6	510	950.0	521.1	970	1778.0	1015.6	1860	3380.0
271.1	520	968.0	526.7	980	1796.0	1026.7	1880	3416.0
276.7	530	986.0	532.2	990	1814.0	1037.8	1900	3452.0
282.2	540	1004.0	537.8	1000	1832.0	1048.9	1920	3488.0
287.8	550	1022.0	548.9	1020	1868.0	1060.0	1940	3524.0
293.3	560	1040.0	560.0	1040	1904.0	1071.1	1960	3560.0
298.9	570	1058.0	571.1	1060	1940.0	1082.2	1980	3596.0
304.4	580	1076.0	582.2	1080	1976.0	1093.3	2000	3632.0
310.0	590	1094.0	593.3	1100	2012.0	1098.9	2010	3650.0
315.6	600	1112.0	604.4	1120	2048.0	1104.4	2020	3668.0
321.1	610	1130.0	615.6	1140	2084.0	1110.0	2030	3686.0
326.7	620	1148.0	626.7	1160	2120.0	1115.6	2040	3704.0
332.2	630	1166.0	637.8	1180	2156.0	1121.1	2050	3722.0
337.8	640	1184.0	648.9	1200	2192.0	1126.7	2060	3740.0
343.3	650	1202.0	660.0	1220	2228.0	1132.2	2070	3758.0
348.9	660	1220.0	671.1	1240	2264.0	1137.8	2080	3776.0
354.4	670	1238.0	682.2	1260	2300.0	1143.3	2090	3794.0
360.0	680	1256.0	693.3	1280	2336.0	1148.9	2100	3812.0
365.6	690	1274.0	704.4	1300	2372.0	1154.4	2110	3830.0
371.1	700	1292.0	715.6	1320	2408.0	1160.0	2120	3848.0
376.7	710	1310.0	726.7	1340	2444.0	1165.6	2130	3866.0
382.2	720	1328.0	737.8	1360	2480.0	1171.1	2140	3884.0
387.8	730	1346.0	748.9	1380	2516.0	1176.7	2150	3902.0
393.3	740	1364.0	760.0	1400	2552.0	1182.2	2160	3920.0
398.9	750	1382.0	771.1	1420	2588.0	1187.8	2170	3938.0
404.4	760	1400.0	782.2	1440	2624.0	1193.3	2180	3956.0
410.0	770	1418.0	793.3	1460	2660.0	1198.9	2190	3974.0
415.6	780	1436.0	804.4	1480	2696.0	1204.4	2200	3992.0
421.1	790	1454.0	815.6	1500	2732.0	1210.0	2210	4010.0
426.7	800	1472.0	826.7	1520	2768.0	1215.6	2220	4028.0
432.2	810	1490.0	837.8	1540	2804.0	1221.1	2230	4046.0
437.8	820	1508.0	848.9	1560	2840.0	1226.7	2240	4064.0
443.3	830	1526.0	860.0	1580	2876.0	1232.2	2250	4082.0
448.9	840	1544.0	871.1	1600	2912.0	1237.8	2260	4100.0
454.4	850	1562.0	882.2	1620	2948.0	1243.3	2270	4118.0
460.0	860	1580.0	893.3	1640	2984.0	1248.9	2280	4136.0
465.6	870	1598.0	904.4	1660	3020.0	1254.4	2290	4154.0
471.1	880	1616.0	915.6	1680	3056.0	1260.0	2300	4172.0
476.7	890	1634.0	926.7	1700	3092.0	1265.6	2310	4190.0
482.2	900	1652.0	937.8	1720	3128.0	1271.1	2320	4208.0
487.8	910	1670.0	948.9	1740	3164.0			
493.3	920	1688.0	960.0	1760	3200.0			

Common Thermometry Fixed Points

Fixed Points from the Practical International Temperature Scale ITS-90

	°C	°F
Triple Point of Hydrogen	-259.35	-434.82
Boiling Point of Hydrogen	-256.15	-429.07
Triple Point of Neon	-248.59	-415.47
Triple Point of Oxygen	-218.79	-361.82
Triple Point of Argon	-189.34	-308.81
Triple Point of Mercury	-38.83	-37.90
Triple Point of Water	0.01	32.02
Melting Point of Gallium	29.76	85.57
Freezing Point of Indium	156.59	313.86
Freezing Point of Tin	231.93	449.47
Freezing Point of Zinc	419.53	787.15
Freezing Point of Aluminum	660.32	1220.58
Freezing Point of Silver	961.78	1763.20
Freezing Point of Gold	1064.18	1947.52
Freezing Point of Copper	1084.62	1984.32

American Wire Gauge Size To Inches

American Wire Gauge (AWG)	Size O.D Inches
6/0	0.5800
5/0	0.5165
4/0	0.4600
3/0	0.4096
2/0	0.3648
1/0	0.3249
1	0.2893
2	0.2576
3	0.2294
4	0.2043
5	0.1819
6	0.1620
7	0.1443
8	0.1285
9	0.1144
10	0.1019
11	0.0907
12	0.0808
13	0.0720
14	0.0641
15	0.0571
16	0.0508
17	0.0453
18	0.0403
19	0.0359
20	0.0320
21	0.0285
22	0.0253

American Wire Gauge (AWG)	Size O.D Inches
23	0.0226
24	0.0201
25	0.0179
26	0.0159
27	0.0142
28	0.0126
29	0.0113
30	0.0100
31	0.00893
32	0.00795
33	0.00708
34	0.00630
35	0.00561
36	0.00500
37	0.00445
38	0.00396
39	0.00353
40	0.00314
41	0.00280
42	0.00249
43	0.00222
44	0.00198
45	0.00176
46	0.00157
47	0.00140
48	0.00124
49	0.00111
50	0.00099

Factors and Prefixes for Forming Decimal Multiples and Sub-Multiples for the SI Units

Factor	Prefix	Symbol	Factor	Prefix	Symbol	Factor	Prefix	Symbol
10 ¹²	tera	T	10	deka	da	10 ⁻⁹	nano	n
10 ⁹	giga	G	10 ⁻¹	deci	d	10 ⁻¹²	pico	p
10 ⁶	mega	M	10 ⁻²	centi	c	10 ⁻¹⁵	femto	f
10 ³	kilo	k	10 ⁻³	milli	m	10 ⁻¹⁸	atto	a
10 ²	hecto	h	10 ⁻⁶	micro	μ			

Corrosive Service Guide to Materials

Chemical	Condition	Material
Acetic Acid	to 50% to 212° F to 75% to 300° F to 99% to 250° F	316 Stainless Steel Titanium Hastelloy C
Acetic Anhydride	All conc. to B.P.	Monel 400
Acetone	All conc. to B.P.	304 SS, Aluminum
Acetylene		304 SS, Aluminum
Alcohol, Ethyl	70° F – 212° F	304 Stainless Steel
Aluminum Sulphate	to 25% and 212° F to 50% and 212° F	304 Stainless Steel 316 Stainless Steel
Ammonia gas or liquid	All concentrations	304 Stainless Steel
Ammonium Hydroxide		1100-1114 Aluminum
Ammonium Phosphate	to 25% and 212° F	304 Stainless Steel
Ammonium Nitrate	All conc. to 212° F	316 Stainless Steel
Ammonium Sulphate	All conc. to B.P. to 45% and 212° F	316 Stainless Steel Monel 400
Amylacetate		304 Stainless Steel
Aniline	All concentrations	
Barium Chloride	25% to B.P.	Hastelloy C
Barium Hydroxide	to 50% 212° F	C1018 Steel
Black Liquor		Alloy 556
Boracic Acid	All conc. to B.P.	Hastelloy C
Brines		Monel 400, Hastelloy C
Bromine Dry	to 212° F	Monel 400
Butane	to 250° F	316 Stainless Steel
Butylacetate	to 212° F	Monel 400
Butyl Alcohol		Copper, Aluminum
Calcium Chlorate	to 30% and 212° F	304 Stainless Steel
Calcium Hydroxide	to 50% and 212° F	Hastelloy C or Titanium
Carbonic Acid	All conc. to 300° F	316 Stainless Steel
Carbon Dioxide	to 1300° F	304 Stainless Steel
Chlorine Gas	Moist to 212° F	Hastelloy C or Titanium
Chromic Acid	10% at 150° F	Hastelloy C

Chemical	Condition	Material
Citric Acid	to 50% 212° F All conc. to B.P.	316 Stainless Steel Hastelloy C
Copper Nitrate	All conc. to 212° F	304 Stainless Steel
Copper Sulphate	All conc. to B.P.	316 Stainless Steel
Cyanogen Gas	to 212° F	304 Stainless Steel
Dowtherm		C1018 Steel
Ether		304 Stainless Steel
Ethyl Acetate	to 150° F	Monel 400
Ferric Chloride	to 50% & B.P.	Tantalum
Ferric Sulphate	to 30% & B.P.	Hastelloy C
Ferrous Sulphate	All conc. to B.C.	Hastelloy C
Formaldehyde	All conc. to 150° F	304 Stainless Steel
Formic Acid	All conc. to 212° F	304 Stainless Steel
Freon		316 Stainless Steel
Gallic Acid	to 212° F	Monel 400
Gasoline or Petroleum		304 Stainless Steel
Glucose	70° F	304 Stainless Steel
Glycerine		304 Stainless Steel
Glycerol		304 Stainless Steel
Hydrobromic Acid	40% to 65° F 48% to 212° F	Titanium Hastelloy B
Hydrochloric Acid	to 37% and 150° F	Hastelloy B
Hydrofluoric Acid	All conc. to B.P.	Hastelloy C
Hydrogen Peroxide	to 212° F	316 Stainless Steel
Hydrogen Sulphide	Dry to 1000° F	316 Stainless Steel
Iodine	to 70° F	Tantalum
Ketones	to B.P.	Aluminum, 316 SS
Kerosene		304 Stainless Steel
Lactic Acid	to 212° F	Tantalum
Magnesium Chloride	to 40% of 212° F	Monel 400
Magnesium Sulphate	to 50% 212° F	Monel 400

WARNING: The corrosive service material selection information provided in this table is to be used only as a guide. Thermowell application environment variations may affect actual performance. Environment variations include process temperature, pressure, flow rate, concentration, purity and solids content. If you have questions relating to thermowell performance in a specific application, we recommend that you contact the factory.

Corrosive Service Guide to Materials

Chemical	Condition	Material
Acetic Acid	to 50% to 212° F to 75% to 300° F to 99% to 250° F	316 Stainless Steel Titanium Hastelloy C
Acetic Anhydride	All conc. to B.P.	Monel 400
Acetone	All conc. to B.P.	304 SS, Aluminum
Acetylene		304 SS, Aluminum
Alcohol, Ethyl	70° F – 212° F	304 Stainless Steel
Aluminum Sulphate	to 25% and 212° F to 50% and 212° F	304 Stainless Steel 316 Stainless Steel
Ammonia gas or liquid	All concentrations	304 Stainless Steel
Ammonium Hydroxide		1100-1114 Aluminum
Ammonium Phosphate	to 25% and 212° F	304 Stainless Steel
Ammonium Nitrate	All conc. to 212° F	316 Stainless Steel
Ammonium Sulphate	All conc. to B.P. to 45% and 212° F	316 Stainless Steel Monel 400
Amylacetate		304 Stainless Steel
Aniline	All concentrations	
Barium Chloride	25% to B.P.	Hastelloy C
Barium Hydroxide	to 50% 212° F	C1018 Steel
Black Liquor		Alloy 556
Boracic Acid	All conc. to B.P.	Hastelloy C
Brines		Monel 400, Hastelloy C
Bromine Dry	to 212° F	Monel 400
Butane	to 250° F	316 Stainless Steel
Butylacetate	to 212° F	Monel 400
Butyl Alcohol		Copper, Aluminum
Calcium Chlorate	to 30% and 212° F	304 Stainless Steel
Calcium Hydroxide	to 50% and 212° F	Hastelloy C or Titanium
Carbonic Acid	All conc. to 300° F	316 Stainless Steel
Carbon Dioxide	to 1300° F	304 Stainless Steel
Chlorine Gas	Moist to 212° F	Hastelloy C or Titanium
Chromic Acid	10% at 150° F	Hastelloy C

Chemical	Condition	Material
Citric Acid	to 50% 212° F All conc. to B.P.	316 Stainless Steel Hastelloy C
Copper Nitrate	All conc. to 212° F	304 Stainless Steel
Copper Sulphate	All conc. to B.P.	316 Stainless Steel
Cyanogen Gas	to 212° F	304 Stainless Steel
Dowtherm		C1018 Steel
Ether		304 Stainless Steel
Ethyl Acetate	to 150° F	Monel 400
Ferric Chloride	to 50% & B.P.	Tantalum
Ferric Sulphate	to 30% & B.P.	Hastelloy C
Ferrous Sulphate	All conc. to B.C.	Hastelloy C
Formaldehyde	All conc. to 150° F	304 Stainless Steel
Formic Acid	All conc. to 212° F	304 Stainless Steel
Freon		316 Stainless Steel
Gallic Acid	to 212° F	Monel 400
Gasoline or Petroleum		304 Stainless Steel
Glucose	70° F	304 Stainless Steel
Glycerine		304 Stainless Steel
Glycerol		304 Stainless Steel
Hydrobromic Acid	40% to 65° F 48% to 212° F	Titanium Hastelloy B
Hydrochloric Acid	to 37% and 150° F	Hastelloy B
Hydrofluoric Acid	All conc. to B.P.	Hastelloy C
Hydrogen Peroxide	to 212° F	316 Stainless Steel
Hydrogen Sulphide	Dry to 1000° F	316 Stainless Steel
Iodine	to 70° F	Tantalum
Ketones	to B.P.	Aluminum, 316 SS
Kerosene		304 Stainless Steel
Lactic Acid	to 212° F	Tantalum
Magnesium Chloride	to 40% of 212° F	Monel 400
Magnesium Sulphate	to 50% 212° F	Monel 400

Speed of Response

The purpose of the information on this page is to give you some general guidelines in estimating the speed of response you might expect from a thermocouple or an RTD.

In defining any transient condition such as a temperature change, it is important that a standard measuring point be established to provide a basis of comparison. In temperature transducers, the time constant is defined as the time required, in seconds, for the temperature sensor to respond through 63.2% of the total temperature change.

The factors affecting the response rate of a temperature probe in a fluid are:

- a) the mass of the probe surrounding the active temperature sensitive point
- b) the thermoconductivity of materials used in manufacturing the transducer
- c) the mass and conductivity of the measured fluid
- d) the velocity of the fluid over the probe

From the above, it is obvious that a probe of small diameter made of highly conductive materials will respond most rapidly to temperature change. Since thermocouple materials will have shorter conductive paths, a thermocouple probe will respond more rapidly than an RTD probe of equal diameter. This is verified by the bar charts:

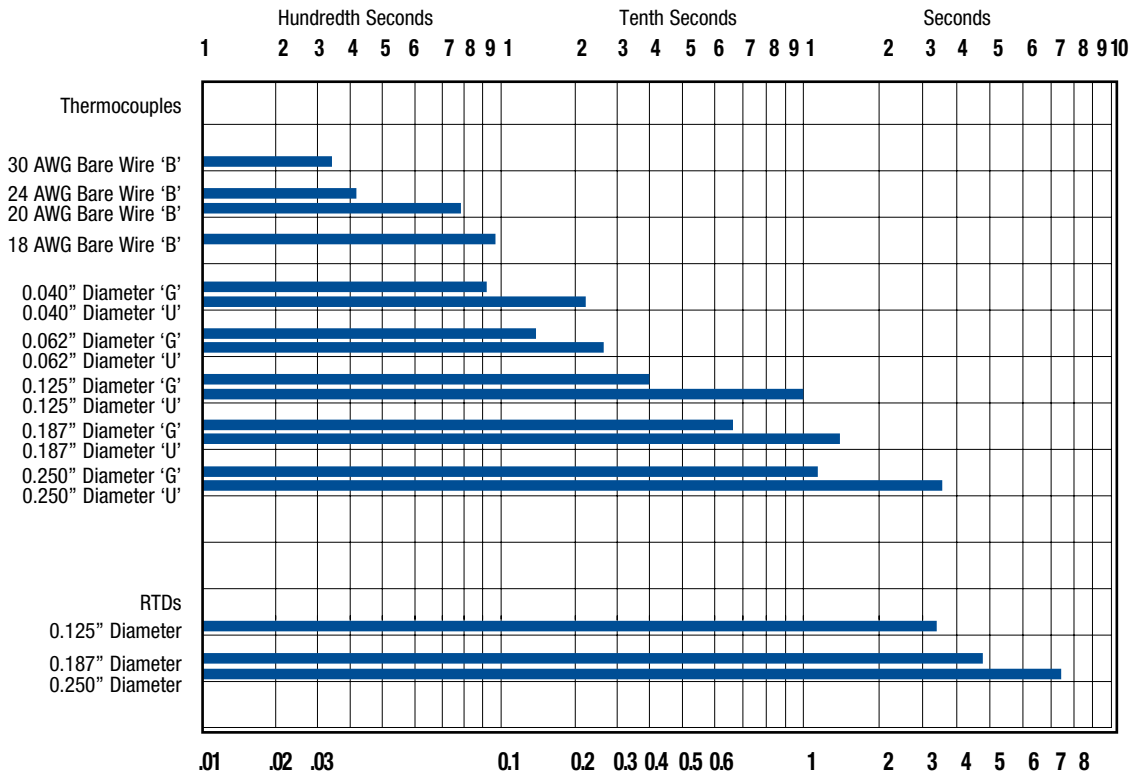

In determining time constants for the bar charts above, tests were performed in still water going through an instantaneous step change from 32°F to 212°F (0°C to 100°C).

For guidelines for determining the time constant for specific probes under other conditions, multiply the time constant from the chart by the following factors:

Condition	Still Air	Air @ 10 ft/Sec.	Water @ 15 ft/Sec.
Factor	20X	4X	.25X

DIAMETER indicated in decimals refers to standard Conax probe diameters. Letters G, U and B correspond with various styles of tip configurations.

Relative Magnitude of Pressure Differential

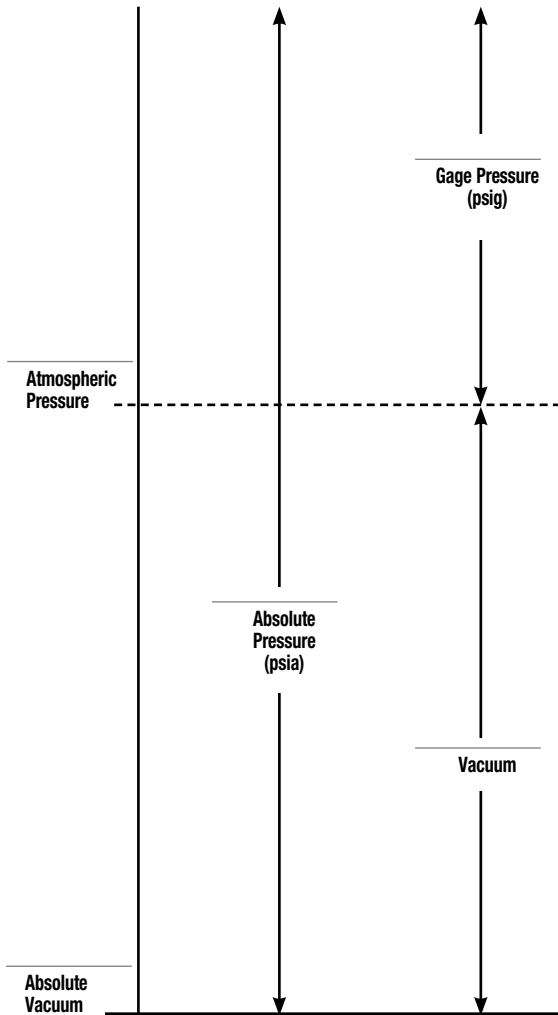

Vacuum Units of Measure

	Absolute Pressure			
	psia	Torr (mm Hg)	mtorr (micron)	Pa (N/m ²)
Atmospheric Pressure	14.696	760	760,000	101,292
Low Vacuum	↓	↓	↓	↓
Medium Vacuum	0.193	1	1,000	133.28
High Vacuum	↓	↓	↓	↓
	1.93x10 ⁻⁵	1.00x10 ⁻³	1	0.133
Absolute Vacuum	0	0	0	0

NPT Pipe Thread Sizes

Pipe Size NPT (IN)	Pipe O.D. (IN)
1/8	0.405
1/4	0.540
3/8	0.675
1/2	0.840
3/4	1.050
1	1.315
1-1/4	1.660
1-1/2	1.900
2	2.375

Pressure/Vacuum Sealing of Wires and Probes

Conax Technologies developed the “soft sealant” method of pressure/vacuum sealing and is still the leading manufacturer of this type of sealing device. Based on the compression of a sealant material within a fixed housing, the practical application of this technology relies on a thorough understanding of the behavior of sealant materials. Conax offers a complete range of pressure/vacuum compression seal feedthroughs for conductors and compression seal fittings for non-conductors including:

- High Temperature Power Seal Feedthroughs
- High Voltage Power Seal Feedthroughs
- Multi-wire Power Seal Feedthroughs
- CSA® HazLoc Power Seal Feedthroughs
- General Purpose Instrumentation Seal Feedthroughs
- High Temperature Instrumentation Seal Feedthroughs
- High Density Instrumentation Seal Feedthroughs
- High Pressure Instrumentation Seal Feedthroughs
- Bearing Sensor Wire Seal Feedthroughs
- Single Element Fittings
- Multiple Element Fittings
- Split Seal Fittings

We also offer a complete line of accessories including torque wrenches, crows feet, socket adaptors and lubrication kits. For more information, request the Conax Pressure and Vacuum Sealing Catalog #5001 or contact a Conax sales engineer.



Conax Multi-Wire Power Compression Seal Feedthrough (PL)



Conax Multi-Hole Metal Compression Seal Fitting (MHM)



Conax Instrumentation Wire Compression Seal Feedthrough (TG)



Conax Power Compression Seal Feedthrough (EGT)



Request our High Temperature Sensor Catalog #6008

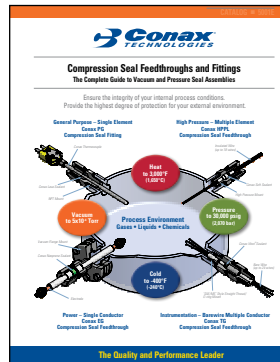

Request our full line Compression Seal Catalog #5001



www.conaxtechnologies.com



2300 Walden Avenue • Buffalo, New York 14225, USA
 Tel: 1.716.684.4500 • USA 1.800.223.2389
 E-mail: sales@conaxtechnologies.com • Fax: 1.716.684.7433
www.conaxtechnologies.com



Conax Technologies is a registered trademark of Conax Technologies LLC. Grafoil is a registered trademark of UCAR Carbon Company. Inconel is a registered trademark of International Nickel Co. Teflon is a registered trademark of E.I. DuPont de Nemours Company. Hanes is a registered trademark of Haynes International, Inc. Viton is a registered trademark of Dow Elastomers LLC. Chromel and Alumel are registered trade names of Concept Alloys LLC. EPSILON is a registered trademark of ASM International. Centura is a registered trademark of Applied Materials Inc. Con-Flat and Klamp-Flanges are registered trademarks of Varian Vacuum Productions. Kwik-Flange is a trademark of MDC Vacuum Products LLC. ISO certification refers to Conax Technologies' Buffalo NY location.