

# Temperature Sensors & Compression Seal Fittings

for Semiconductor Processing

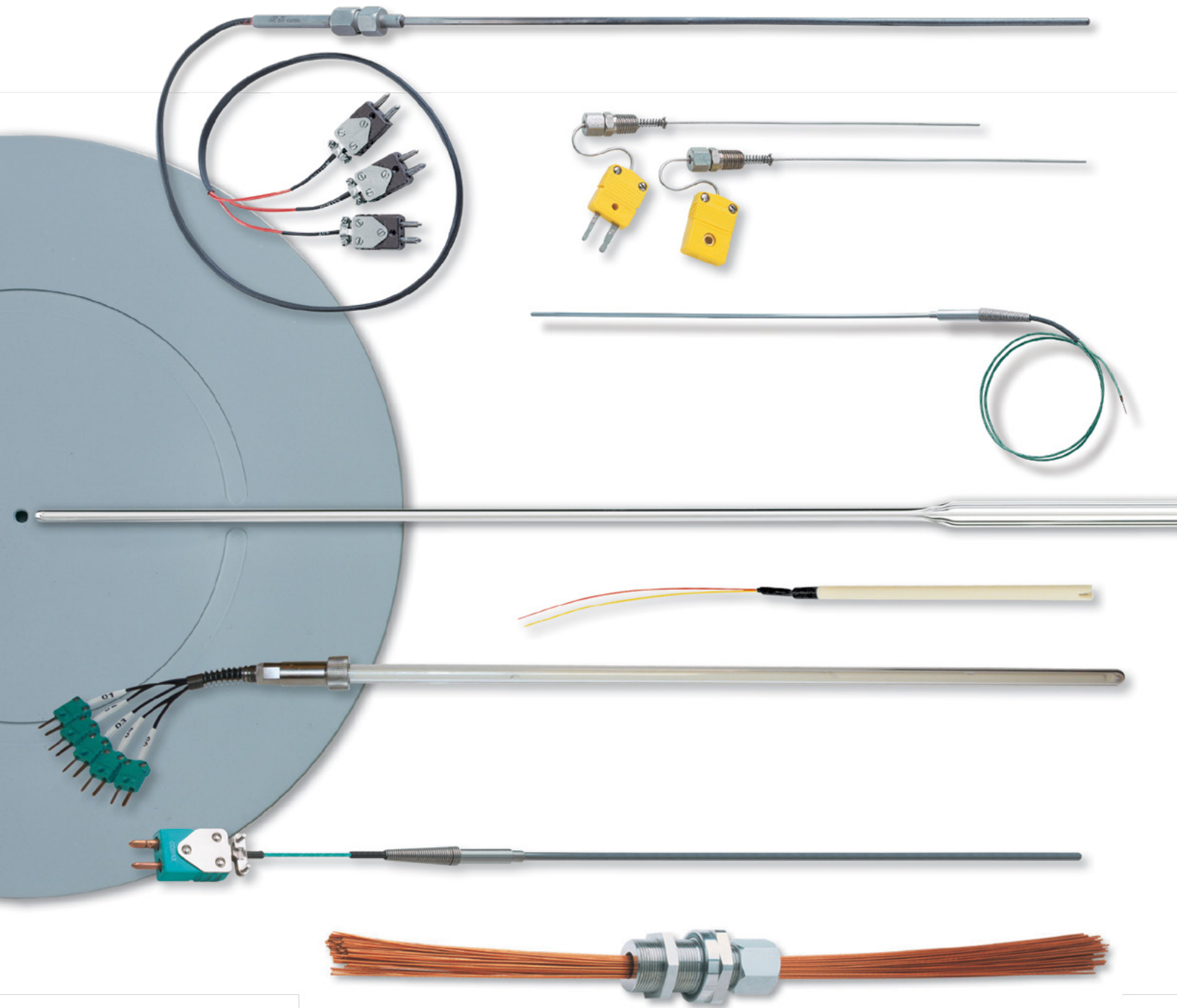

**Conax**  
TECHNOLOGIES

Ideas. Solutions. Success.

+1 716 684 4500

+1 800 223 2389

conax@conaxtechnologies.com

## Conax Semiconductor

Conax meets the demanding needs of the semiconductor industry with a wide range of temperature sensors and sealing devices specifically designed for the unique requirements of this industry. Conax Semiconductor offers standard products that can be easily adapted to meet the most challenging processes and applications of this industry. In addition, Conax Semiconductor design engineers are continuously at work to develop new sensor and compression seal fitting configurations to support the needs of this rapidly changing field.

Drawing on our 60 year history of innovation, our engineers are capable of meeting the customized needs of our customers' product design challenges. From material processing to finished-product testing, our sensor/compression seal fitting designs provide value-based performance and reliability even in the most challenging environments.

### Wafer Processing



- 1** Profile thermocouples are available for both vertical and horizontal furnaces. 3-zone and 5-zone thermocouples may be manufactured with varying wire diameters and calibration types. For more applications of this product, see page 6.
- 2** Spike thermocouples and torch thermocouples may be supplied with flying leads, connectors or other custom configurations. For more applications of this product, see page 6.
- 3** Conax Semiconductor manufactures an extensive line of thermocouples for the ASM Epsilon Epitaxial Reactor. See further details starting on page 4.
- 4** Triple-Point calibration thermocouple for the Applied Materials/Moore Technologies Epitaxial Barrel Reactor.
- 5** Single-Point version of the calibration thermocouple for the Applied Materials/Moore Technologies Epitaxial Barrel Reactor.
- 6** Typical alumina sheathed dual junction, dual seal thermocouple used in general furnacing and ingot furnacing applications.
- 7** Small diameter thermocouples with spring loading used in applications such as ion implantation.
- 8** Fiber optic vacuum feedthrough used in applications such as passing laser signals into and out of UHV photolithography tools for precise stage movement measurements.

## High Brightness LED & MEMS Production

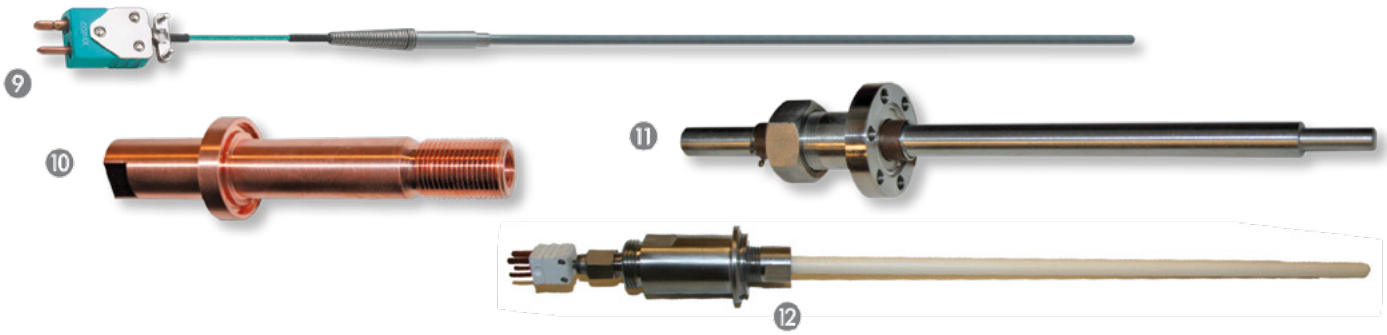

**9** Susceptor temperature control thermocouple with molybdenum sheath used in MOCVD reactors used to produce High Brightness LEDs.

**10** Water cooled copper electrode typically used to supply power to heating elements in MOCVD reactors.

**11** Compression seal fitting with rebuildable molybdenum electrode typically supplies power to heating elements in MOCVD reactors. This design eliminates fragile ceramic-to-metal seal style electrode feedthroughs.

**12** Typical alumina sheathed dual junction, dual seal thermocouple used in polycrystalline PV and ingot furnacing applications.

## Photovoltaic

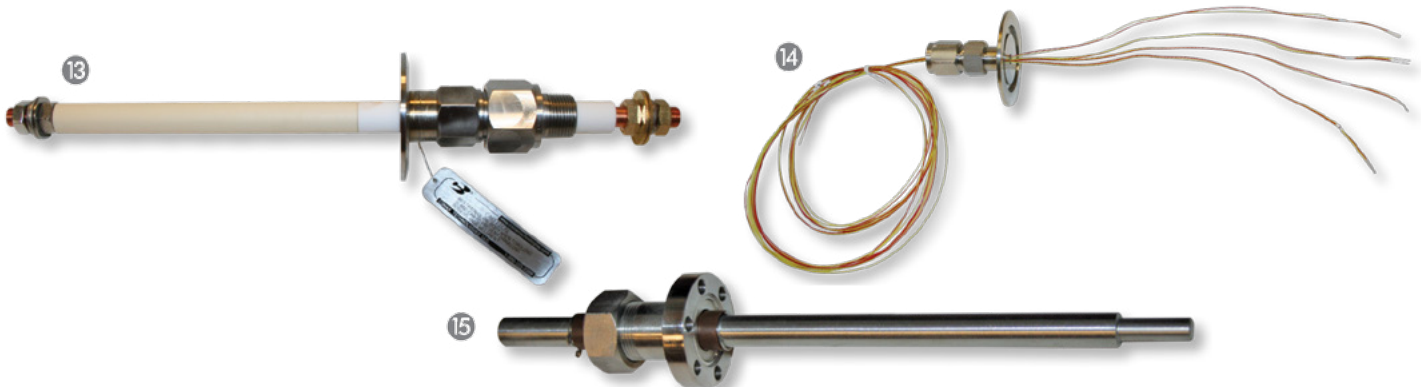

**13** Typical electrode feedthrough with vacuum flange for supplying power to furnace heating elements in thin-film PV panel production.

**14** Thermocouple wire feedthrough used to pass thermocouple signals through a vacuum pressure boundary.

**15** Compression seal fitting with rebuildable molybdenum electrode typically supplies power to heating elements in MOCVD reactors. This design eliminates fragile ceramic-to-metal seal style electrode feedthroughs.

## Package & Test

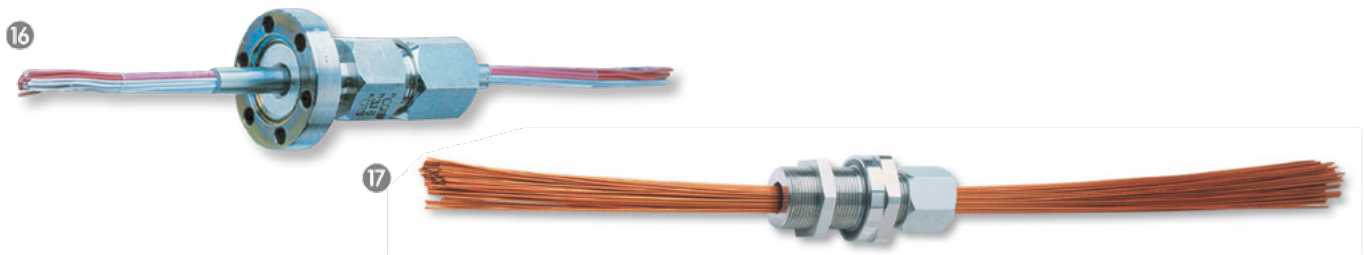

**16** High density feedthrough with vacuum flange mount used to introduce copper signal and thermocouple wires into HAST (Highly Accelerated Stress Test) chamber.

**17** Custom designed MHM fitting with O-ring seal for introducing large-diameter wires into HAST chamber.

## Thermocouples for ASM Epsilon® Reactors

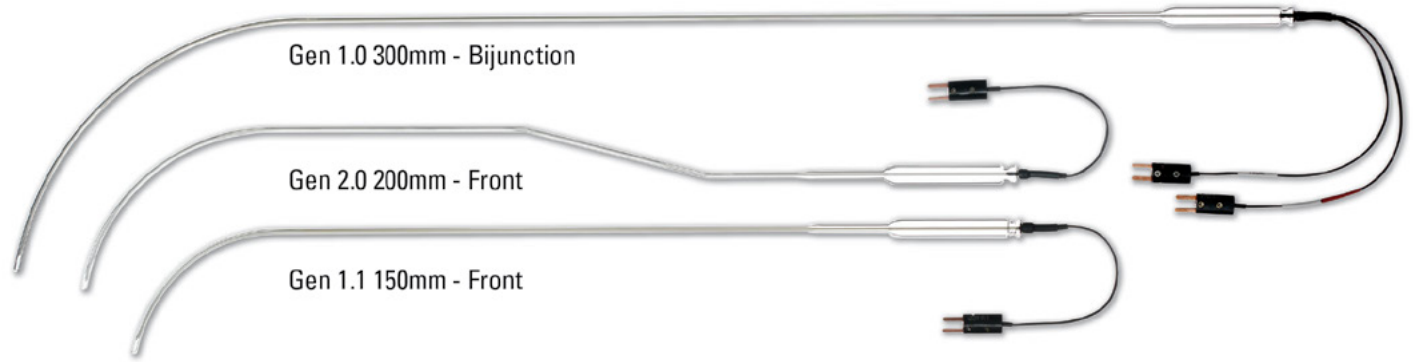

### Product Features

- 150mm, 200mm, and 300mm sets are available.
- Type R thermocouples meeting special limits of error per ASTM E230.
- Sheaths are manufactured from semiconductor-grade quartz tubing.
- Laser engraved serial numbers are easy to read and are used for complete material and build traceability.

### Laser Engraving Examples



- Each sensor is heat sealed into two bags that are suitable for use with clean room procedures.
- Square-cut insulator segments improve performance by minimizing thermocouple calibration drift caused by vapor phase transport of rhodium to the pure platinum leg of the sensor. Others take shortcuts by removing large portions of the insulator, thereby allowing the insulator to break at curved points of the sheath. This causes large areas of the wire surface to be exposed, thereby increasing the potential for cross-contamination and subsequent drift to occur.



### Conax Services

- Quartz re-sheathing option is available.
- Platinum reclamation program is available.
- All thermoelements used in the construction of our sensors are calibrated using industry recognized American Society for Testing and Materials (ASTM) procedures with temperature standards traceable to National Institute of Standards and Technology (NIST). Individual sensors can be custom calibrated upon request.
- Allow Conax Semiconductor to carry your inventory to ensure next day delivery if required. Contact us for details.
- Transmitters can be provided to convert the thermocouple output into a 4-20mA current loop output.

## Gen 1.x Sets Provide OEM Performance

The two versions of our Conax Gen 1.x sets are for those fabs that want typical OEM performance and thermocouple life.

Our Gen 1.0 sensors are manufactured from custom-sized quartz sheaths as specified by the OEM.

Conax Gen 1.1 sensors are interchangeable with Gen 1.0, but are manufactured from standard-sized quartz tubing. Sensor life is typically 10%-30% more compared to the OEM standard version, at a lower price.

## Gen 2.x Sets Last 40-250% Longer

Conax Gen 2.x sensors are designed to provide longer service life over their Gen 1.x counterparts without modifying your reactor. A combination of different wire sizes, quartz sheath variations and non-diffused center tips contribute to the longer life of the Gen 2.x family.

By lasting 40-250% longer, a Conax Gen 2.x set will decrease the number of PMs required solely to change out thermocouples, thereby significantly increasing reactor uptime and wafer starts per month.

**Example:** Our longer-lasting Gen 2.0 thermocouples have allowed one of our 150/200mm EPI customers to **reduce by 50%** the number of PMs required solely to change out thermocouples. This gives them the ability to process more wafers, translating to a projected **\$1+ million** annual increase in finished product revenue per reactor.

## Custom Designs are Available

Conax will work with your engineering staff to create special variations of any sensor so that it is uniquely designed to accomplish your specific objectives.

Some options we can offer include variations in diffusion treatment of the quartz sheath, multiple junctions contained within a single sheath, special junction locations and other dimensional variations.

Thermocouples - Front - Side - Rear - Bijunction											
Susceptor Size	Standard Life ASM Reference P/N	Typical Standard OEM Probe Life - Gen 1.0		10 - 30% Improved Quartz Life - Gen 1.1			Susceptor Position	40 - 250% Improved Quartz Life - Gen 2.X			Long Life ASM Reference P/N
		Gen 1.0.8 Conax P/N	Gen 1.0.1 Conax P/N	Gen 1.1.8 Conax P/N	Gen 1.1.1 Conax P/N	Gen 1.1.2 Conax P/N		Gen 2.0.5 & Gen 2.0.8 Conax P/N	Gen 2.1.8 Conax P/N	Gen 2.1.1 Conax P/N	
150mm	02-323647D01	10-0710-001	10-0710-101	10-0794-001	10-0794-101	#	Front	10-0959-001	10-1803-001	10-1803-101	02-352119D01
	02-323649D01	10-0711-001	10-0711-101	10-0793-001	10-0793-101	#	Side	10-0958-001	10-1801-001	10-1801-101	02-352078D01
	02-323648D01	10-0709-001	10-0709-101	10-0792-001	10-0792-101	10-1768-204	Rear	10-0942-004	10-1766-004	10-1766-104	02-352076D01
200mm	02-327874D01	10-0712-001	10-0712-101	10-0795-001	10-0795-101	#	Bijunction	10-1003-001	10-1831-001	10-1831-101	02-352074D01
	02-323652D01	10-0074-001	10-0074-101	10-0745-001	10-0746-101	#	Front	10-0957-001	10-1804-001	10-1804-101	02-352118D01
	02-323654D01	10-0073-001	10-0073-101	10-0745-001	10-0745-101	#	Side	10-0956-001	10-1802-001	10-1802-101	02-352072D01
	02-323653D01	10-0072-001	10-0072-101	10-0744-001	10-0744-101	10-1768-201	Rear	10-0942-001	10-1766-001	10-1766-101	02-352070D01
300mm	02-327875D01	10-0459-001	10-0459-101	10-0747-001	10-0747-101	#	Bijunction	10-1004-001	10-1832-001	10-1832-101	02-352066D01
	N/A	10-0924-001	10-0924-101	#	#	#	Front	#	10-1829-001	10-1829-101	N/A
	02-178706D01	10-0925-001	10-0925-101	#	#	#	Side	#	10-1827-001	10-1827-101	N/A
	02-178705D01	10-0923-001	10-0923-101	#	#	#	Rear	#	10-1826-001	10-1826-101	N/A
	02-178704D01	10-0926-001	10-0926-101	#	#	#	Bijunction	#	10-1828-001	10-1828-101	N/A
Thermocouples - Center											
Susceptor Size	Standard Life ASM Reference P/N	Typical Standard OEM Probe Life - Gen 1.0		10 - 30% Improved Quartz Life - Gen 1.1			Susceptor Position	40 - 250% Improved Quartz Life - Gen 2.X			Long Life ASM Reference P/N
		Gen 1.0.8 Conax P/N	Gen 1.0.1 Conax P/N	Gen 1.1.8 Conax P/N	Gen 1.1.1 Conax P/N	Gen 1.1.2 Conax P/N		Gen 2.0.5 Conax P/N	Gen 2.1.8 Conax P/N	Gen 2.1.1 Conax P/N	
150mm & 200mm	02-321895D01	10-0708-001	10-0708-101	10-0743-004	10-0743-104	10-1767-204	Center - ATM (ground tip)	10-0941-004	10-1607-004	10-1607-104	02-352105D01
	02-330816D01	#	#	10-1065-004	10-1065-104	#	Center - ATM (non-ground tip)				
	02-323584D01	10-0461-001	10-0461-101	10-0743-001	10-0743-101	10-1767-201	Center - RP (ground tip)	10-0941-001	10-1607-001	10-1607-101	02-352105D02
02-330816D02	10-0787-001	10-0787-101	10-1065-001	10-1065-101	#	Center - RP (non-ground tip)					
300mm	02-178674D01	10-0922-001	10-0922-101	#	#	#	Center	#	10-1830-001	10-1830-101	N/A
	02-146866-01	#	#	#	#	#		#	#	#	N/A
	02-144677-01	10-0922-004	10-0922-104	#	#	#		#	#	#	N/A

# = Contact Conax for more information

© 2008 Conax, Inc. All Rights Reserved

## Profile and Spike Thermocouples for Diffusion Furnaces

### Standard or Customized Designs

Choose from one of our standard designs for either vertical or horizontal type furnaces. Or we can work with you to develop a new or customized design. Both profile and spike thermocouples are available in the following Pt-Rh noble metal calibration types: Type B, Type R and Type S. They are also available in base metal calibration Type K and Type N. Standard wire sizes are 0.020" (0,5mm) and 0.010" (0,25mm) with optional size 0.012" (0,30mm) also available.



Profile thermocouples are available for both vertical and horizontal furnaces. Sheath material is semiconductor grade quartz in 8mm, 10mm or 12mm outside diameters. The quartz sheaths may be equipped with a 28/15 socket for mating up to a ball joint if your furnace is so equipped.

The internal thermocouples are typically supplied with a 3-zone or 5-zone configuration. The thermocouple wire can populate either a single 6-hole or 10-hole insulator. Alternatively, the wires can populate three or five 2-hole insulators.

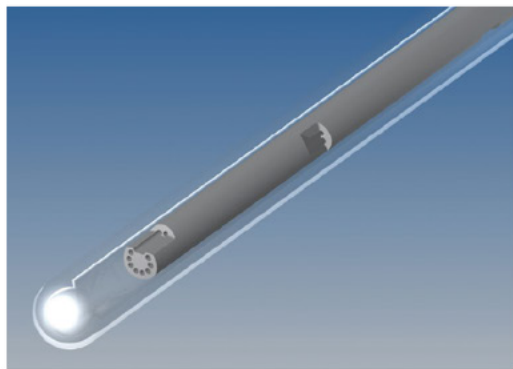

6-hole or 10-hole insulator

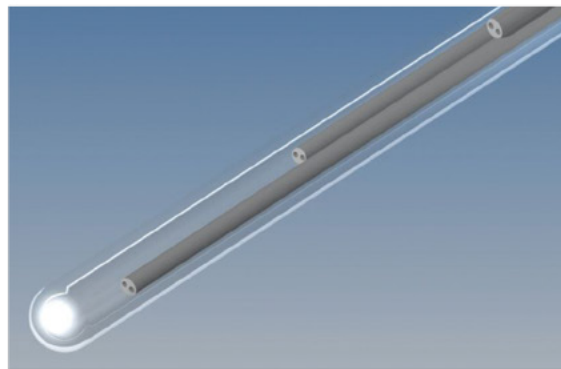

Three or five 2-hole insulators

Connectorization is accommodated by standard or miniature 2-pin connectors. Multi-pin screw or bayonet-style connectors are also offered. The lead wires between the probe and the connectors run continuously using the same noble metal thermocouple wire as is installed in the quartz sheath. As a cost savings option, Conax Semiconductor can transition to extension grade for the lead wires.

See the following chart for more details.

### Tolerance of Thermocouples Extension Wire

ANSI/ASTM	Temperature Range (°C)	Tolerance (°C)	Temperature Range (°F)	Tolerance (°F)
SX	0 to 200	± 5.0	32 to 400	± 9.0
RX	0 to 200	± 5.0	32 to 400	± 9.0
BX <sup>1</sup>	0 to 200	± 4.2	32 to 400	± 7.6
B <sup>2</sup>	0 to 100	± 3.7	32 to 200	± 6.7

<sup>1</sup> Proprietary alloy compensating extension wire is available for use over a wide temperature range.

<sup>2</sup> Special compensating extension wires are not necessary with Type B over the limited temperature range 0° C to 50° C (32° F to 125° F), where the use of non-compensated (copper/copper) conductors introduces no significant error. For a somewhat larger temperature gradient of 0° C to 100° C (32° F to 210° F) across the extension portion of the circuit, the use of non-compensated (copper/copper) extension wires may result in small errors, the magnitude of which will not exceed the tolerance values given in the table above for measurements above 100° C (200° F).

## Single Spike Thermocouple vs Dual Spike Thermocouple

Spike thermocouples or torch thermocouples may be ordered as single or dual (two measuring junctions). Dual spike thermocouples are often used for a redundant measurement in the event one circuit fails. Duals may also be used to track sensor drift. This is accomplished by populating one of the dual circuits with a different calibration wire (typically R, S or B) than the other circuit. As the thermocouple circuits age, they will drift. Different calibrations will drift at different rates. Comparing the rate of drift differential will give an indication as to the amount of drift the particular dual spike is experiencing, and by extension, the rate of drift for the other spikes. Spike recalibration or replacement decisions may be made based on objective criterion rather than arbitrary time-based maintenance schedules.

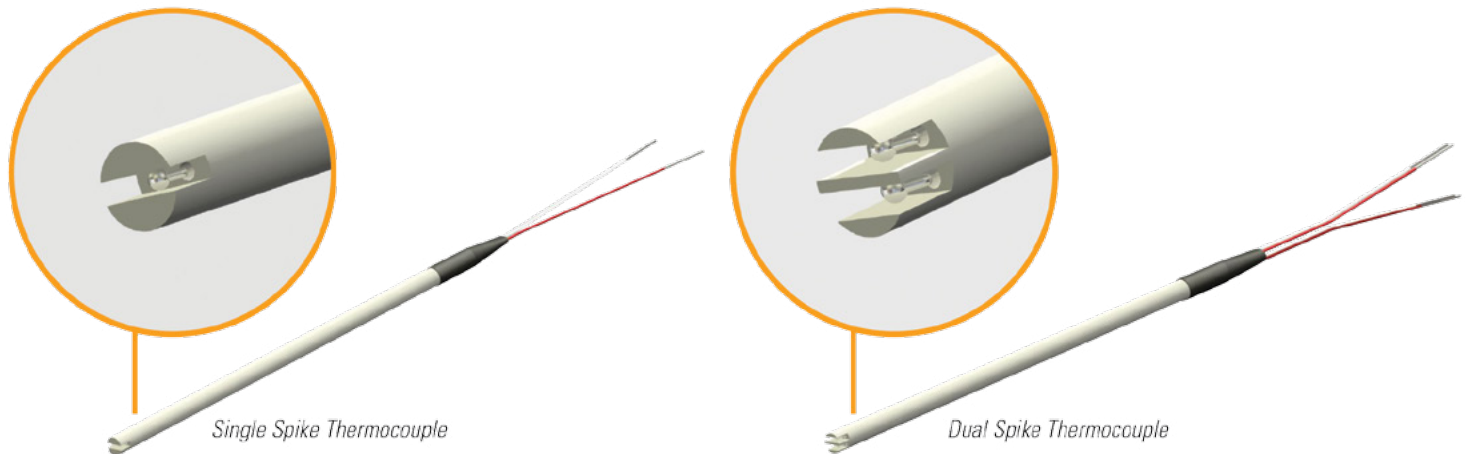

## Calibration Capabilities

Various types of calibration data are available with your thermocouple purchase. Conax Semiconductor can provide a Bulk Wire Calibration Certificate which provides calibrations results (standard temperatures) on each lot of wire prior to the wire being released for production. We can also provide calibration data at user specified temperatures. We can also provide calibration of your Profile Thermocouple in chart form over a defined temperature range. The offsets may be provided in degrees Celsius or in millivolt or microvolt format.

All calibrations are conducted under the guidance of our quality system, certified to ISO 9001:2008, and are performed by comparison techniques as defined in ASTM E220. Conax Semiconductor utilize thermocouple primary and working standards which are traceable directly to NIST.

We use some of the most accurate and state-of-the-art data acquisition hardware available in the industry today. Data acquisition during the calibration process is highly automated. Our calibration system automatically collects data, converts the thermocouple millivolt signal to a temperature, and compares this information to the standard. This determines the offset and acceptance to defined limits. This is all performed without technician intervention, thereby eliminating possible human error.

Profile thermocouples offer a unique calibration challenge because of their long length and the fact that multiple thermocouples are located along the length of the unit. Conax Semiconductor has developed a unique system which employs a specially designed, 60" long calibration furnace that allows us to simultaneously calibrate up to five, 5-point Diffusion Thermocouples at a single time (ex., 25 total thermocouples).

## Our Production Facilities

Inside of our specialized semi assembly production area, we utilize laminar flow tables to assemble our temperature sensors in a clean environment.

Our packaging and delivery processes are performed meticulously to ensure that our sensors arrive at your door on time and ready to install. Visit our website to learn more about these procedures.

Our instruments are tested and calibrated against standards that are traceable to NIST standards and conform to the latest industry specifications and protocols. We utilize a state-of-the-art computer controlled data acquisition system which provides computer generated calibration reports, ensuring data accuracy and integrity by eliminating potential human errors in recording/reporting.



*Our Laminar Flow Tables Certified 209E Class 100*

## The Experience and Ingenuity to Meet any Application Requirement...

The examples shown in this brochure represent just a sampling of what Conax Semiconductor can do for you. Today we manufacture more than 100,000 standard assemblies in our state-of-the-art production facilities.

In most cases, our wide variety of off-the-shelf products can be combined to meet the needs of your application.

For those truly unique requirements, our engineers are standing by to put more than 60 years of experience to

work designing the perfect solution for your application. Many of our custom designs have now become industry standards.

Our knowledgeable, experienced staff would welcome the opportunity to discuss your application and recommend solutions.

**Call Conax Semiconductor at +1 800 223 2389 today!**

---

2300 Walden Avenue, Buffalo, New York 14225  
**+1 800 223 2389 (P) | +1 716 684 7433 (F)**  
**conax@conaxtechnologies.com**  Made in U.S.A.  
Bulletin 6003, Rev E ©2016 Conax Technologies 10/16

  
**Conax**  
TECHNOLOGIES  
Ideas. Solutions. Success.

[conaxtechnologies.com](http://conaxtechnologies.com)

