

QuadraTherm



 The Thermal Mass Flow Meter for High Accuracy Air, Gas, and Mixture Flow Measurement





SIERRA

QuadraTherm

10246.98 SCFM
69.46 F



Thermal mass flow **accuracy** you never imagined possible.

Manufacturing and industrial process control depend on the highest accuracy air, natural gas, and gas mixture flow measurement possible to assure maximum productivity, efficiency and end-product quality.

Today, Sierra's revolutionary QuadraTherm® 640i and 780i deliver the world's most accurate thermal mass flow measurements. Accuracy is as good as, if not better, than Coriolis, at a fraction of the price. Now experience precise mass flow rate, temperature and pressure measurement from a single device.

Dry Sensor Breakthrough

In the late 1990's, Sierra experienced its first major breakthrough with the introduction of DrySense™, a patented all-metal "dry" mass velocity sensor, which was a significant performance advantage over so-called "wet" sensors of the time. Because no organic sensor potting compounds are used, there is no sensor drift. Sierra is so confident in DrySense sensor technology, we back our DrySense sensors with a lifetime warranty.

As a result of Sierra's dry sensor breakthrough and the performance advantage experienced by thousands of companies in a wide variety of industries, Sierra is now North America's best-selling thermal mass flow meter (Flow Research, Boston, MA).

Beyond Traditional Thermal

An even more impactful breakthrough came in 2012 with the invention of QuadraTherm flow sensor technology. Thermal performance has never been the same.

Unlike traditional two-sensor thermal mass flow meters, QuadraTherm has four sensors—three precision platinum temperature sensors and one patented no-drift DrySense mass velocity sensor. For the first time, performance improvements abound as unwanted heat-transfer components are now calculated and eliminated. These components show up as false flows that degrade accuracy—factors like stem conduction, sensor cross-talk, radiation, and even natural convection.

Accuracy is now twice as good as conventional thermal meters at +/-0.5% of reading. Flow range

capability has tripled from 20,000 to 60,000 sfp (305 smps), and gas mixing and field compositional compensation is now possible.

The Flow Engine Behind it All

At the heart of every QuadraTherm mass flow meter is advanced digital signal processing to enhance thermal mass flow metering technology and thermodynamic measurements.

Sierra's Raptor™ OS is the true "brain" of the instrument and includes a revolutionary, living, learning algorithm set made possible by today's powerful microprocessors. Raptor manages changes in gas flow, temperature and pressure, as well as outside temperature, via a comprehensive heat-transfer model in the meter firmware.

The result is a proprietary, fundamentally different gas mass flow rate calculation using all pertinent variables for the most precise, stable and accurate flow measurement possible.

Raptor interfaces with Sierra's many software apps to read and adjust in the field.



640i insertion



780i inline

640i/780i Highlights

- Accuracy:
+/- 0.5% of reading (inline);
+/- 0.75% of reading (insertion)
- Gases: Air, natural gas, mixtures, flammables, inert gases
- Flow rates: Down to 0.03 smps (0.1 sfps) & up to 305 smps (60,000 sfpm)
- Pipe/duct sizes up to 72" (182 cm)
- Hot-tap probe retractor
- 100:1 turndown
- Free user software
- Multivariable: Mass flow rate, temperature & pressure
- In-Situ calibration validation
- Built in flow conditioning
- No moving parts, low pressure drop
- Patented QuadraTherm four-sensor design
- DrySense no-drift sensor with lifetime warranty
- Raptor OS "Brain" manages all inputs
- Sierra's fluid library, improves over time
- Multi-language capable
- Digital communications
- Hazardous area approvals

Notable Apps

- ValidCal Diagnostics
- Flow Totalizer
- Meter/Signal tuning
- Dial-A-Pipe: Change pipe size
- Dial-A-Gas: Change gas type
- qMix: Make & upload gas mixtures, retain accuracy

It Has Apps

QuadraTherm is the first thermal mass flow meter to come with comprehensive software apps for ease of use, field adjustment, and calibration validation.

Easily change pipe sizes and measured fluid in the field with apps like Dial-A-Pipe™ and Dial-A-Fluid™. (See center image)

Field Calibration Validation

QuadraTherm features field calibration validation through its ValidCal™ Diagnostic software app. This is only possible with its DrySense no-drift velocity sensor. Costly shutdowns and annual factory recalibration charges are now eliminated.

Custom Gas Mixes

Each QuadraTherm comes with Sierra's proprietary qMix gas mixing software app that empowers you to create custom gas mixtures and perform meter updating in the field with no expensive factory recalibration required.

Flare Gas Breakthrough

QuadraTherm is the only thermal mass flow meter that maintains accuracy even when gas composition changes. The meter works with the qMix app to adjust and match real-time readings from a gas chromatograph (GC). This can be done automatically or manually. In auto mode, update frequency can be set by time or by percent change in composition.

Standard QuadraTherm Sensor / Multivariable

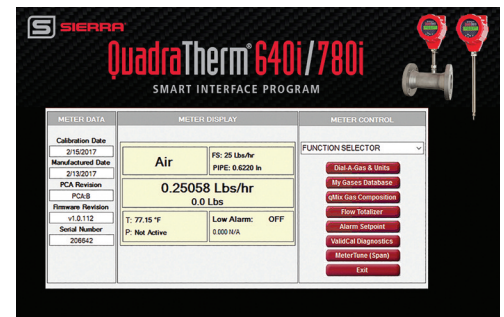
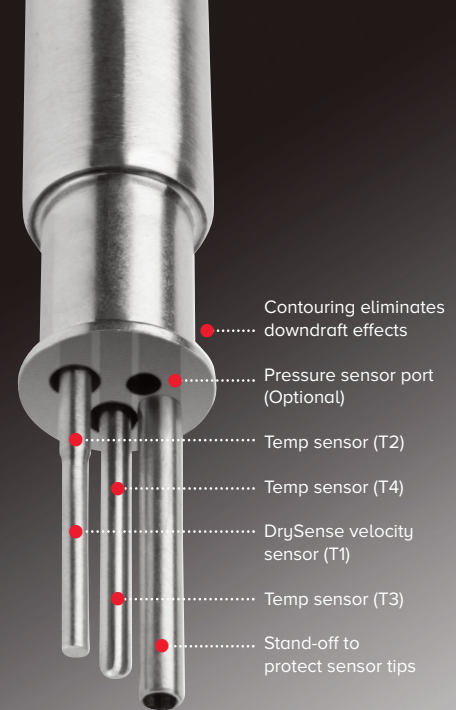

QuadraTherm Sensor with Optional Shield

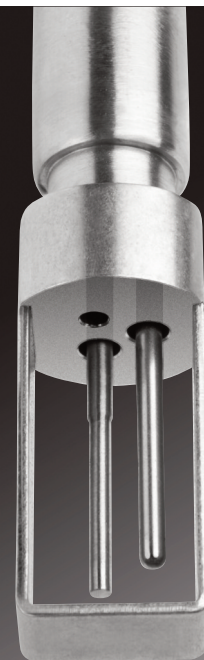

The user can also collect flow and composition trend analysis, flow alarming, and triggers.

Sierra has many more apps under development to enhance your product experience. When released, you can immediately download and begin using them.

SierraLoop World Class Calibration

Designed by Sierra and located at our metrology headquarters in Monterey, California, SierraLoop™ is among the world's most accurate private gas flow calibration facilities.

Rated at +/- 0.3% of reading, all calibrations follow the guidelines of ISO 17025 and are traceable to national standards such as NIST (United States National Institute of Standards and Technology).

Fully automated, once flow application data is programmed, SierraLoop automation software manages all aspects of flow calibration testing. It performs high-speed time-aligned data acquisition and performance analysis over the entire flow measurement range, and generates a calibration certificate documenting instrument performance.

Service, Commissioning & Training

The need to deliver fast, localized support to global customers has resulted in the establishment of dedicated Sierra Flow Centers on almost every continent. And they are backed up by technical experts in over 150 locations in more than 50 countries.

Sierra's team of engineers can commission your flow meter to assure optimal performance and train you to get the most out of your instrument.

We provide lifetime support for all Sierra products and will get on a plane to help you when necessary.

Sierra's Big-3 Technologies

QuadraTherm is one of three advanced flow meter technologies Sierra has developed to help facility managers tackle tough energy management challenges.

For what we call our Big-3, Sierra has become a recognized expert in thermal mass (QuadraTherm®), vortex shedding (InnovaMass®), and transit-time ultrasonic (InnovaSonic®). Sierra is the only company in the USA to manufacture all three flow technologies.

The Big-3 are optimized to be a complete solution for flow energy measurement—facility flows that impact costs like compressed air, natural gas, steam, and hot or chilled water.

As new apps and improvements become available, all Big-3 technologies benefit and are field firmware upgradable.

Watch the Video

sierrainstruments.com/thermal-principle



PERFORMANCE SPECIFICATIONS

Gas Measured

All inert gases and all non-condensing clean gases
 Flammable gases: methane, propane, hydrogen, digester gas, natural gas
 Corrosive gases compatible with 316L stainless steel
 qTherm Gas Library: most common gases and mixtures; air is standard;
 qTherm Dial-A-Gas option for choice of three additional gases

Mass Velocity Range for Air

0 to 60,000 sfpm (0 to 305 smps) at 21.1°C (70°F), 1 atm

Multivariable Outputs

Mass flow rate (standard)
 Temperature (standard)
 Pressure (optional)
 Totalized flow: totalized value is stored in non-volatile memory

Mass Flow Accuracy

780i Inline version accuracy (highest accuracy):*
 +/- 0.5% of reading above 50% of the full scale flow
 +/- 0.5% of reading plus 0.5% of full scale below 50% of full scale flow

640i Insertion version accuracy:*
 +/- 0.75% of reading above 50% of the full scale flow
 +/- 0.75% of reading plus 0.5% of full scale below 50% of full scale flow

See Table 1: qTherm Dial-A-Gas Selection Chart on next page for accuracy.
 Gas pressure accuracy +/- 1.0% full scale
 Totalize each gas independently with the flow totalizer

* Accuracy statements verified by an independent NIST and NVLAP accredited metrology laboratory.

Gas Temperature Accuracy

+/- 1°C (1.8°F)

Gas Pressure Ranges

30 psia (2.1 bara), 100 psia (6.9 bara), 300 psia (20.7 bara),
 500 psia (34.5 bara), VTP only.

Repeatability

Mass flow rate: +/- 0.15% of full scale
 Gas temperature: +/- 0.5°C (0.9°F)
 Gas pressure: +/- 0.5% of full scale

Response Time

Three seconds to achieve 63% (one time constant) of final value

Mass Flow Rate Turndown

100:1

ANALOG AND DIGITAL OUTPUTS

Output Signals

4-20 mA flow, 4-20 mA temperature, 4-20 mA pressure (optional)
 Alarm output (contact SPST/opto relays)
 User definable pulse output for totalized flow

Optional Communications Modules

Modbus, Foundation Fieldbus, Profibus DP, HART

SOFTWARE

Smart Interface Program (SIP) Software

Use Dial-A-Gas and Dial-A-Pipe for easy field setup
 Use Meter Tune to optimize performance
 Use ValidCal to validate all meter functions
 Use flow totalizer to totalize all four Dial-A-Gases independently
 Use qMix gas mixing feature to create custom gas and gas mixtures

POWER REQUIREMENTS

Input Power

100 to 240 VAC (0.4 Amps RMS at 230 VAC)
 24 VDC +/- 10%, 1.04 Amps

OPERATING SPECIFICATIONS

780i Inline Version Gas Pressure Requirements

NPT: 500 psia (34.5 bara) maximum

Flange process connections defined by the ASME B 16.5a – 1998 spec. group rating of 316L stainless steel ANSI class 150 or 300 class flanges (special)
 316L stainless steel 150 class flanges:
 230 psig at -20°F to 100°F; 195 psig at 200°F;
 175 psig at 300°F; 160 psig at 400°F; and 145 psig at 500°F
 Equivalent DN PN16 flanges are available (see page 10 for sizes)
 316L stainless steel 300 class flanges (special):
 600 psig at -20°F to 100°F; 505 psig at 200°F; 455 psig at 300°F;
 415 psig at 400°F

640i Insertion Version Gas Pressure Maximums (or limits)

Compression fittings: 500 psia (34.5 bara)
 1-inch 150 class flange (-40°F to 250°F) 185 psia (12.8 bara)
 Low pressure hot tap: 150 psia (10.3 bara)
 High pressure hot tap: 230 psia (15.9 bara)
 Minimum pipe size 2 inches (50 mm)

Gas Temperature Requirements (all versions)

-40°F (-40°C) to 392°F (200°C)
 High temperature (HT) option to 750°F (400°C) available in 640S model only

Ambient Temperature (NAA and cFMus versions)

-40°F (-40°C) to 140°F (60°C)
 ATEX/IECEx Versions -4°F(-20°C) to 140°F (60°C)

PHYSICAL SPECIFICATIONS

User Interface

Local keypad with a six-button interface
 Exit ⊗ Enter ← Four-way directional arrows ◀ ▶ ▶ ▶
 RS-232 with PC software for communication and programming

Digital Display

UltraBright, backlit, LCD digital display, 2 x 16, 2 x 32 scrolling

780i Inline Version Process Connections

See page 9 and 10 for NPT, ANSI class 150 flange and PN16 DN sizes.

640i Insertion Version Process Connections

See page 6 through 8 for insertion sizes.
 ANSI 1-inch - ANSI class 150 flange (optional)
 Low pressure hot tap rated to 150 psia (10.3 bara)
 High pressure hot tap and retractor 230 psia (15.9 bara)

Wetted Materials

316 SS and 316L SS flow body and Pt/Ir (velocity sensor)
 Viton® VTP Pressure Option
 Neoprene®, Kal-Rez® optional

Leak Integrity

5 x 10⁻⁹ sccs of helium maximum

Approval Agencies

cFMus—Explosion proof for Class I, Div I, Groups B,C,D
 CE—European Conformity
 ATEX/IECEx

Enclosure

NEMA 4 (IP66), hazardous-area explosion proof, flow pointer, meter information tag. NEMA 4X (E2 option only).

TABLE 1: qTherm Dial-A-Gas Selection Chart				
Gas	780i Accuracy		640i Accuracy	
	Actual Gas ⁽¹⁾	qTherm Dial-A-Gas ⁽²⁾	Actual Gas ⁽¹⁾	qTherm Dial-A-Gas ⁽²⁾
Air ⁽³⁾	±0.5%	N/A	±0.75%	N/A
Ammonia	N/A	±3.0%	N/A	±3.0%
Argon	±0.5%	±3.0%	±0.75%	±3.0%
Carbon Dioxide	±0.5%	±3.0%	±0.75%	±3.0%
Chlorine	N/A	±3.0%	N/A	±3.0%
Digester Gas (60% CH ₄ , 40% CO ₂)	±0.5%	±3.0%	±0.75%	±3.0%
Helium	±0.5%	±3.0%	±0.75%	±3.0%
Hydrogen	±0.5%	±3.0%	±0.75%	±3.0%
Methane	±0.5%	±3.0%	±0.75%	±3.0%
Nitrogen	±0.5%	±3.0%	±0.75%	±3.0%
Oxygen	N/A	±0.5%	N/A	±0.75%
Propane	±0.5%	±3.0%	±0.75%	±3.0%
Other ⁽⁴⁾ —Consult Factory	Special Calibration Request (SCR)	Special Calibration Request (SCR)	Special Calibration Request (SCR)	Special Calibration Request (SCR)

Notes: (1) % of reading at >50% of full scale flow; add 0.5% of full scale below 50% of full scale flow
 (2) % of full scale
 (3) Air is standard on the instrument and cannot be removed
 (4) The qTherm Gas Library is a proprietary gas property index that is continually updated and improved

TABLE 2: 640i/780i Straight Run Requirements				
Piping Condition	Upstream 640i Insertion	Upstream 780i Inline with Flow Conditioning ⁽¹⁾	640i Downstream ⁽²⁾	780i Downstream ⁽²⁾
Single 90° Elbow or T-Piece	15D	1D	1D	0D
Two Elbows (in the same plane)	20D	3D	3D	0D
Two Elbows (in different plane)	40D	3D	3D	0D
Reduction (4:1)	15D	3D	3D	0D
Expansion (4:1)	30D	3D	3D	0D
After Control Valve	40D	5D	5D	0D

Notes: (1) Number of diameters (D) of straight pipe required between upstream disturbance and the flow meter
 (2) Number of diameters (D) of straight pipe required downstream of the flow meter

780i INLINE PRESSURE DROP

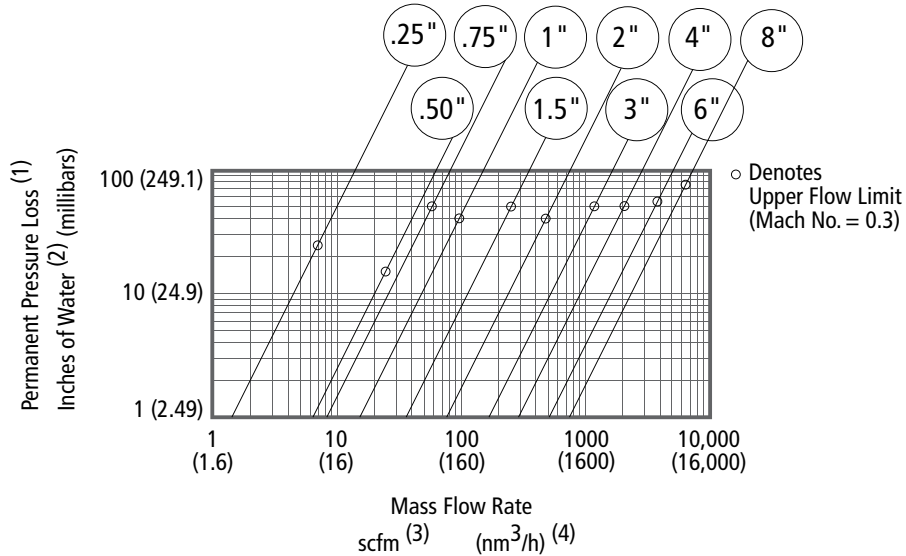

Notes: (1) For air and nitrogen at 20°C temperature and 1 atmosphere pressure
 (2) 1 inch of water at 60°F = 0.0361 psi
 (3) At base conditions of 21.1°C temperature and 1 atmosphere pressure
 (4) At base conditions of 0°C temperature and 1 atmosphere pressure

P2-DD—Side View

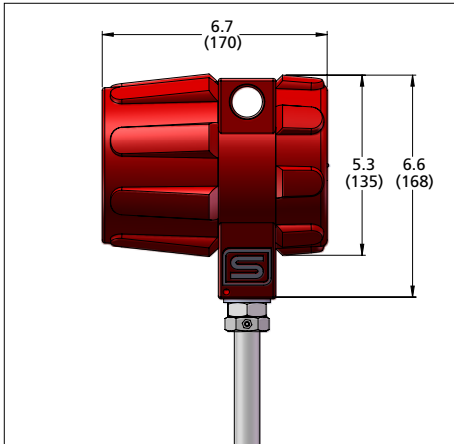

P3-DD—Side View

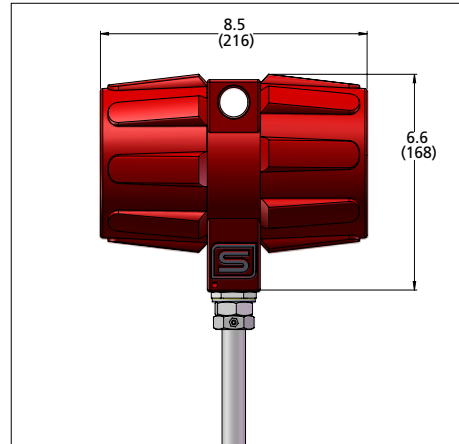

All Versions—Front View

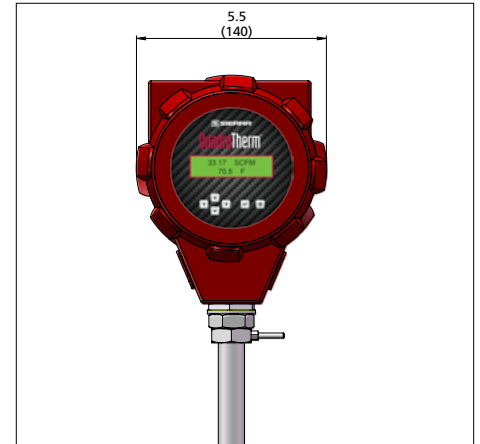

P2-DD Compression Fitting—Side View

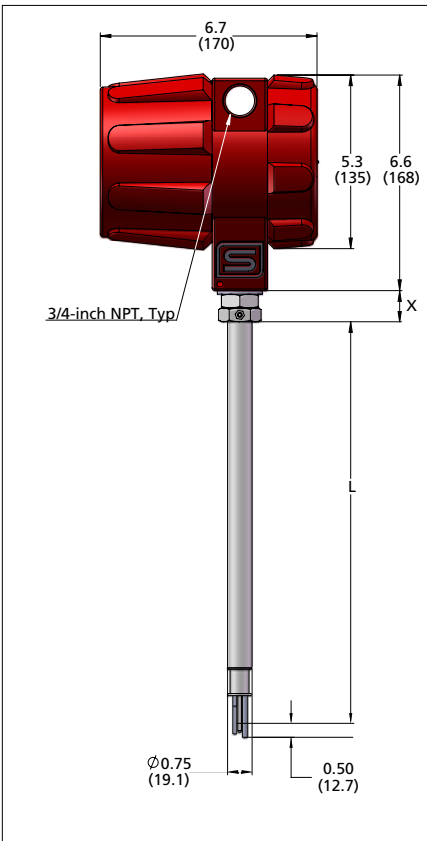

P2-DD Flange Fitting—Side View

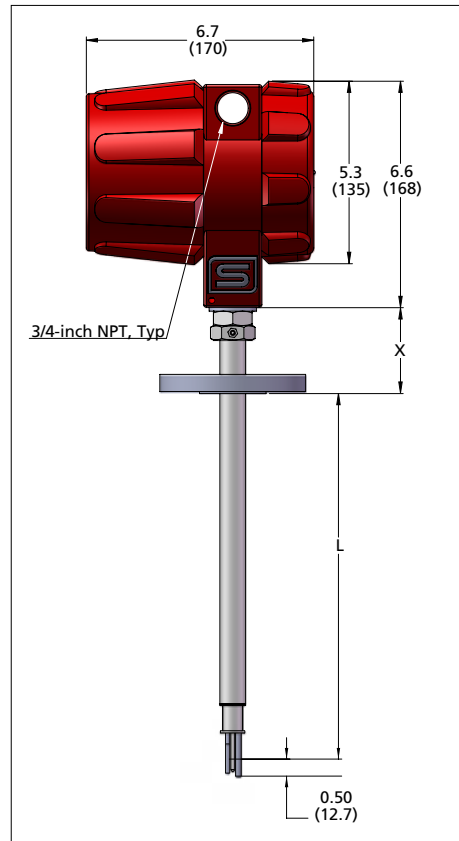

cFMus, ATEX, IECEx Approved Probes (> 13")

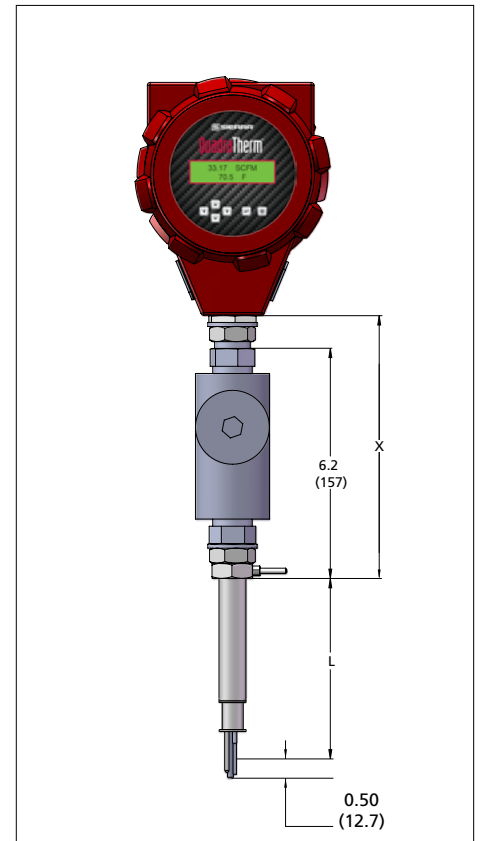

Note: All dimensions in inches with (mm) in brackets; certified drawings available upon request. All drawings have $\pm .25$ inch (6.4 mm) tolerance.

Length Chart 640i
Compressions Fittings

Code	L	X
L06	6.0 (152)	1.25 (31.75)
L09	9.0 (229)	1.25 (31.75)
L13	13.0 (330)	1.25 (31.75)
L18	18.0 (457)	1.25 (31.75)
L24	24 (610)	1.25 (31.75)
L36	36 (914)	1.25 (31.75)
L48	48 (1219)	1.25 (31.75)

Length Chart 640i
Flange Mounting

Code	L	X
L06	6.0 (152)	2.69 (68.33)
L09	9.0 (229)	2.69 (68.33)
L13	13.0 (330)	2.69 (68.33)
L18	18.0 (457)	2.69 (68.33)
L24	24 (610)	2.69 (68.33)
L36	36 (914)	2.69 (68.33)
L48	48 (1219)	2.69 (68.33)

Length Chart 640i
FM Version

Code	L	X
L06	6.0 (152)	10.25 (260.35)
L09	9.0 (229)	10.25 (260.35)
L13	13.0 (330)	10.25 (260.35)
L18	18.0 (457)	10.25 (260.35)
L24	24 (610)	10.25 (260.35)
L36	36 (914)	10.25 (260.35)
L48	48 (1219)	10.25 (260.35)

Remote Electronics VT, VTP—Side View

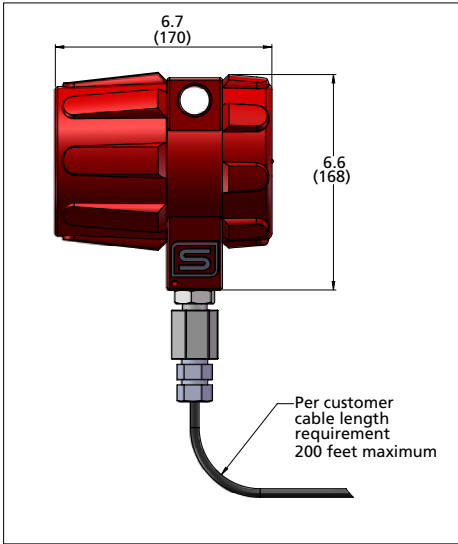

Remote Probe VT—Front View

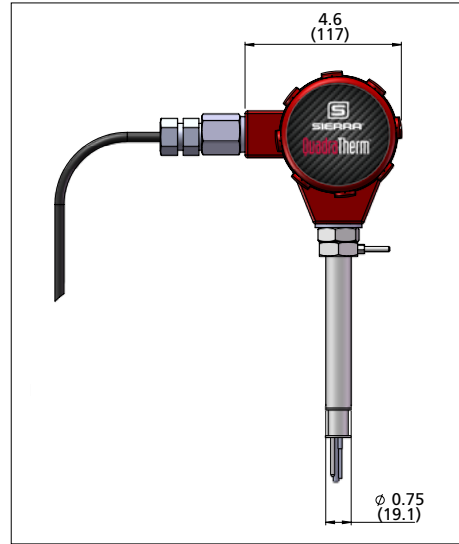

Remote Probe VT—Side View

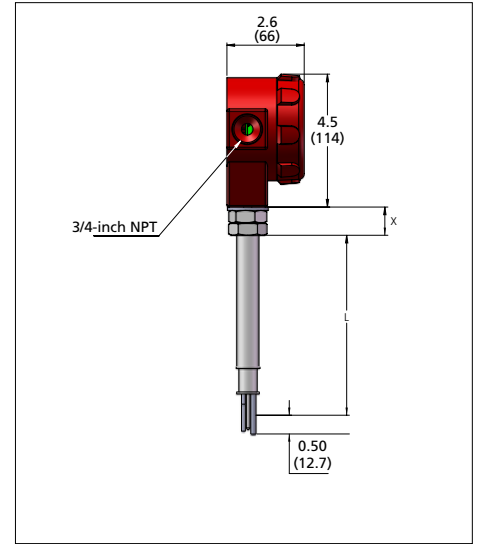

Remote Probe VTP—Front View



Remote Probe VTP—Side View

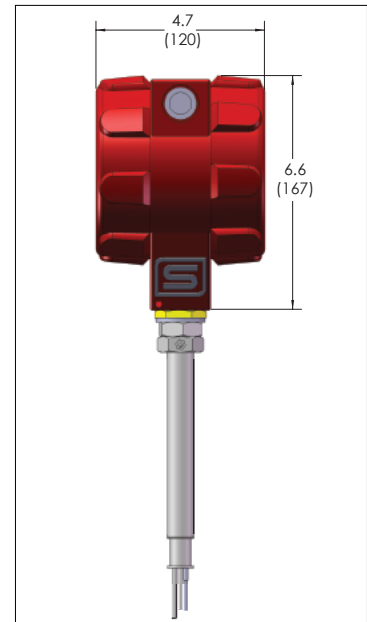

P3-DD Remote Bracket—Side View

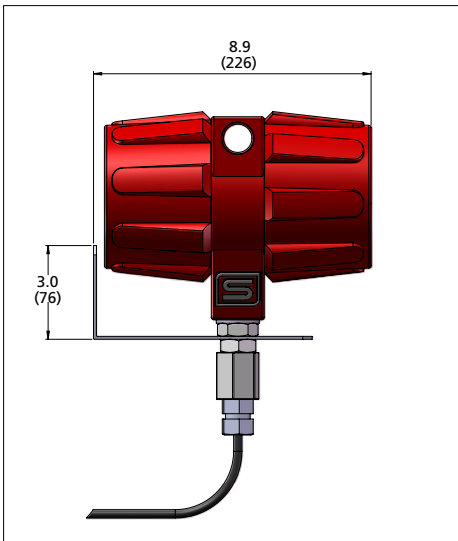

P2-DD Remote Bracket—Side View

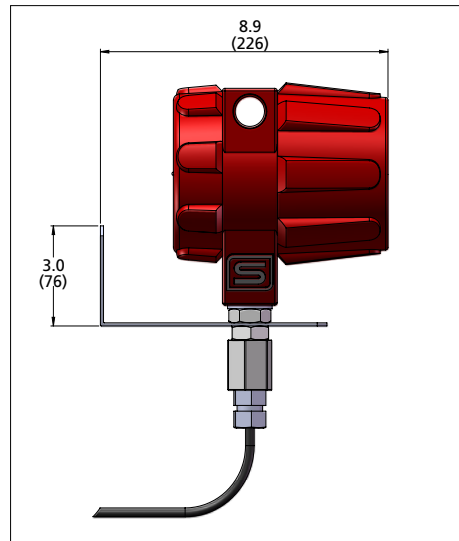

Remote Bracket—Front View

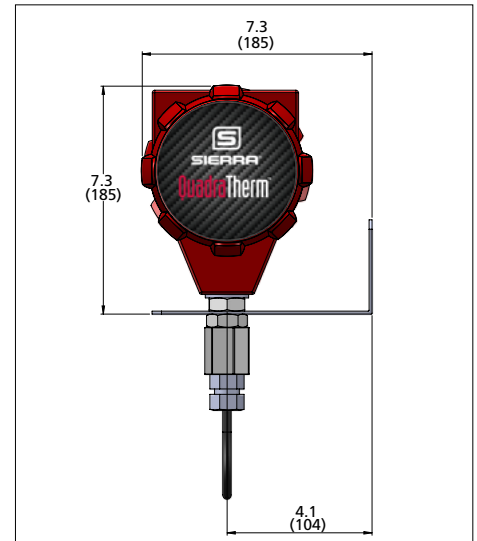

Note: All dimensions in inches with (mm) in brackets; certified drawings available upon request. All drawings have ± .25 inch (6.4 mm) tolerance.

Mounting Holes for Remote Bracket

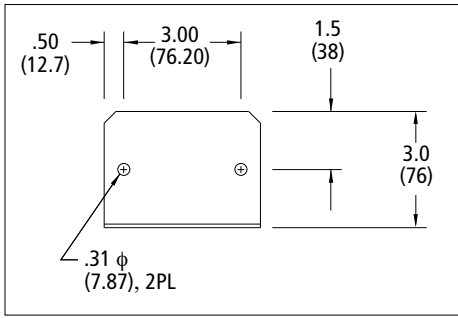

Length Chart 640i Remote Mount Junction Box		
Code	L	X
L06	6.0 (152)	1.25 (37.75)
L09	9.0 (229)	1.25 (37.75)
L13	13.0 (330)	1.25 (37.75)
L18	18.0 (457)	1.25 (37.75)
L24	24 (610)	1.25 (37.75)
L36	36 (914)	1.25 (37.75)
L48	48 (1219)	1.25 (37.75)

640i INSERTION LOW PRESSURE HOT TAP to 150 psig (10.3 barg)

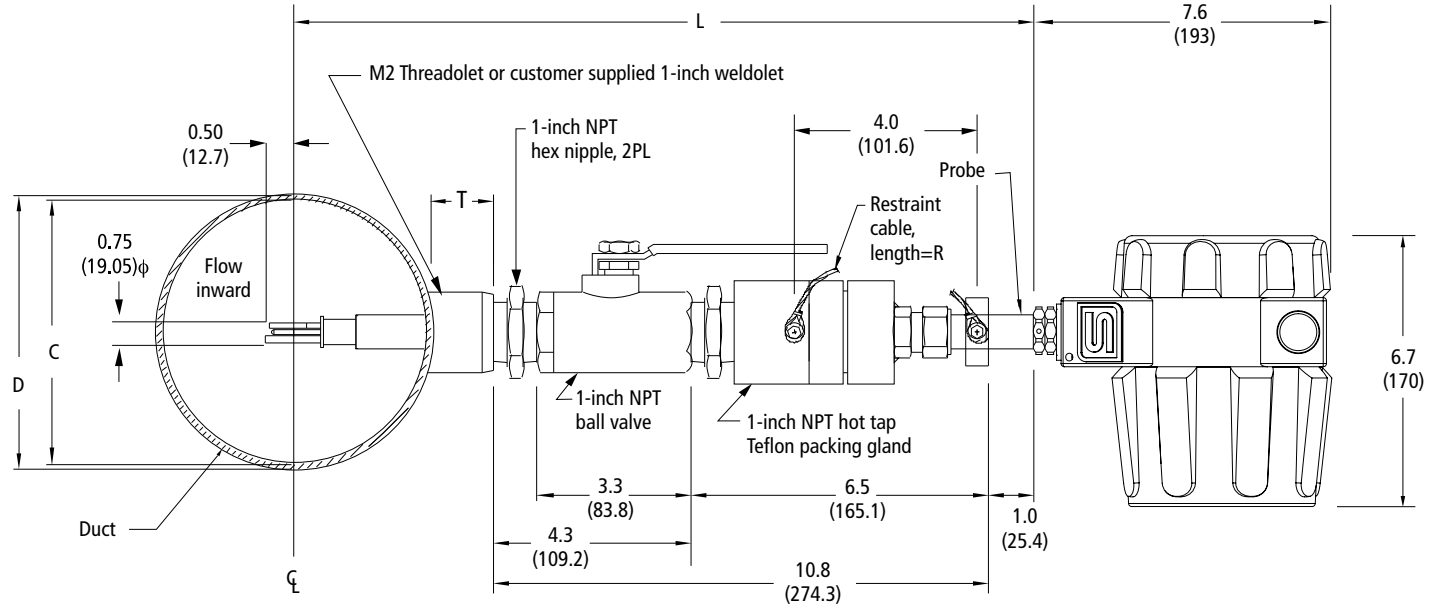

Variables

- L = Nominal Probe Length
- D = Duct O.D.
- C = Duct I.D.
- T = Height of "Threadolet" or Customer Provided Weldolet
- R = Restraint Cable Length

Formula

- $L > 12.3 + T + D/2$
- So L must be equal or greater than 12.3-inches plus the height of the "Threadolet" plus half the duct O.D.
- $R = D/2 + T + 7.3$

640i HIGH PRESSURE HOT TAP is flange dependent up to 400 psig (27.6 barg)

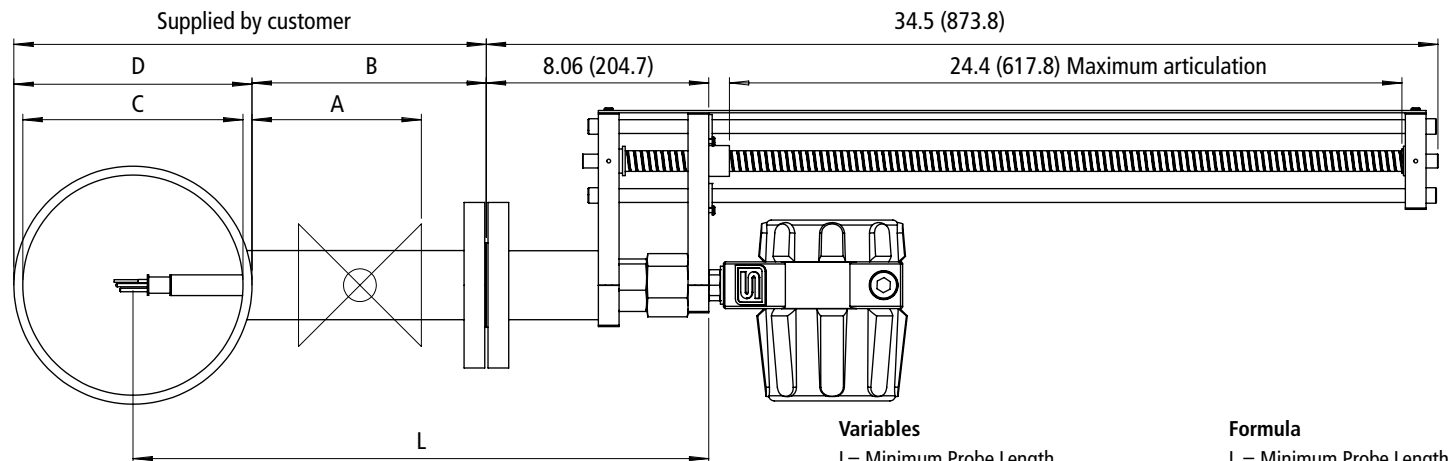

Variables

- L = Minimum Probe Length
- A = Distance From Duct OD To Valve Outlet
- B = Distance From Duct OD To Flange Face
- C = Duct Inner Diameter
- D = Duct Outer Diameter

Formula

- L = Minimum Probe Length
- $L = 8 + B + 1/2 D$
- $D/2 + A \leq 24.4$

Note: All dimensions in inches with (mm) in brackets; certified drawings available upon request

1/2" Through 1 1/2" NPT—Side View

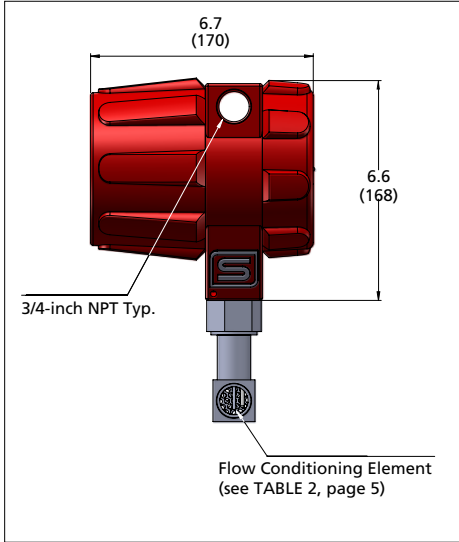

1/2" Through 1 1/2" NPT—Front View

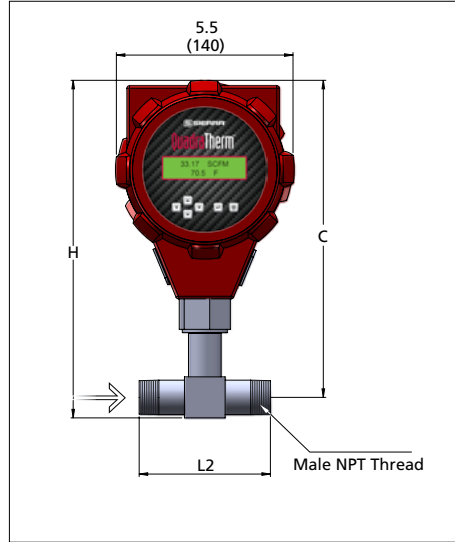

Sizes for NPT			
Size	H	C	L2
1/2-inch	10.5 (267)	9.9 (251)	7.5 (191)
3/4-inch	10.8 (274)	9.9 (251)	7.9 (201)
1-inch	11.2 (284)	9.9 (251)	8.3 (211)
1 1/2-inch	11.5 (292)	9.9 (251)	9.5 (241)

1/2" Through 1 1/2" 150 Class Flange—Side View

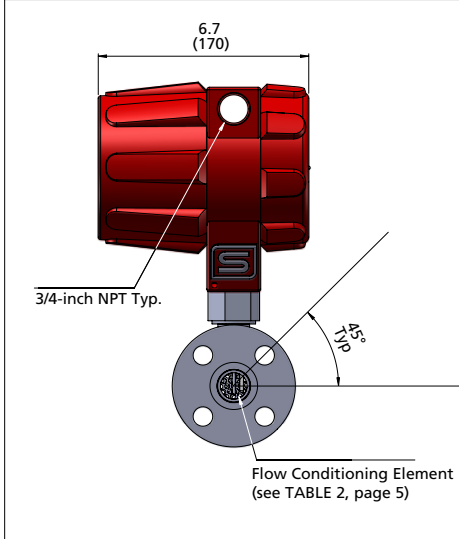

1/2" Through 1 1/2" 150 Class Flange—Front View

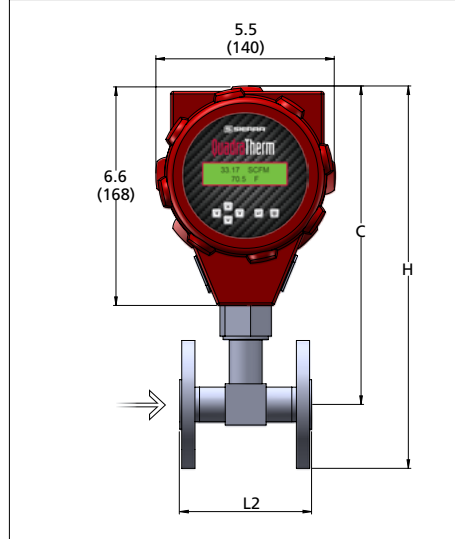

Sizes For ANSI Class 150 Flange			
Size	H	C	L2
1/2-inch	11.6 (295)	9.9 (251)	7.5 (191)
3/4-inch	11.8 (300)	9.9 (251)	7.9 (201)
1-inch	12.0 (304)	9.9 (251)	8.3 (211)
1 1/2-inch	12.2 (310)	9.9 (251)	9.5 (241)

NPT Remote Electronics—Side View

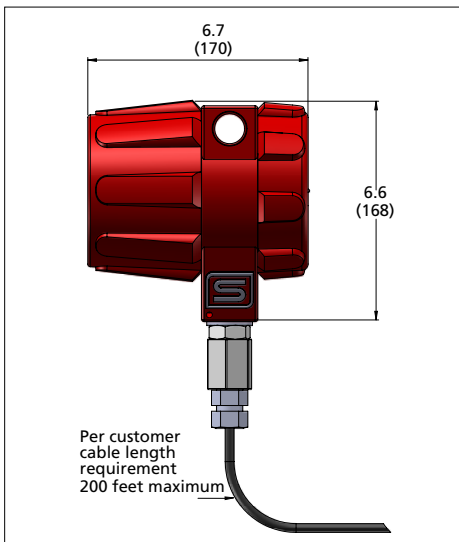

NPT, VTP Remote—Front View

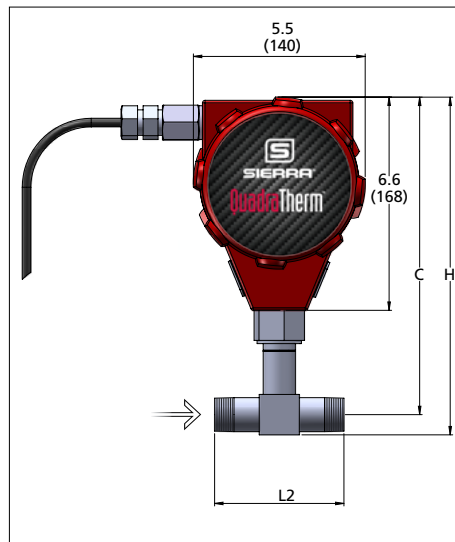

150 Class Flange Remote—Front View

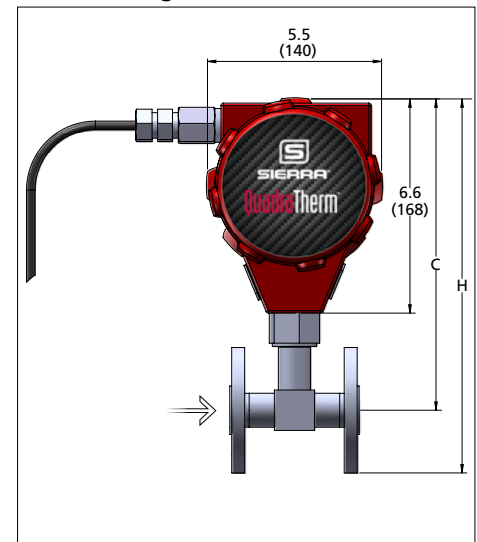

Note: All dimensions in inches with (mm) in brackets; certified drawings available upon request

2" Through 8" 150 Class Flange—Side View

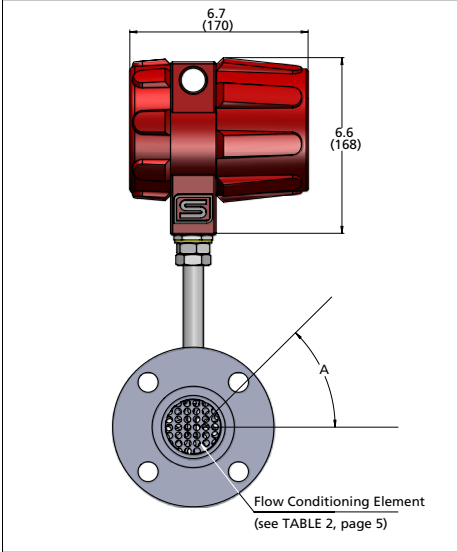

2" Through 8" 150 Class Flange—Front View

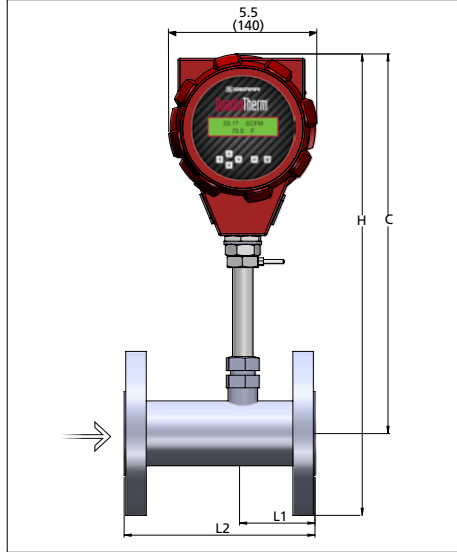

Sizes for ANSI Class 150 Flanges					
Size	H	C	L1	L2	A
2-inch	17.0 (432)	14.0 (356)	2.6 (66)	7.0 (178)	45
3-inch	17.7 (450)	14.0 (356)	2.6 (66)	10.0 (254)	45
4-inch	18.5 (470)	14.0 (356)	3.6 (91)	12.0 (305)	22.5
6-inch	19.5 (495)	14.0 (356)	5.6 (142)	18.0 (547)	22.5
8-inch	20.7 (526)	14.0 (356)	7.6 (193)	24.0 (610)	22.5

2" Through 8" NPT—Side View

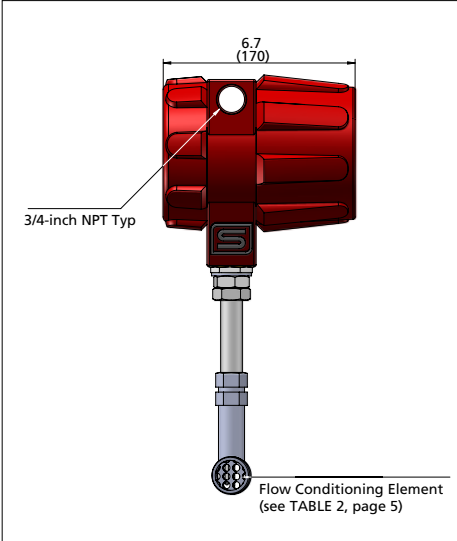

2" Through 8" NPT—Front View

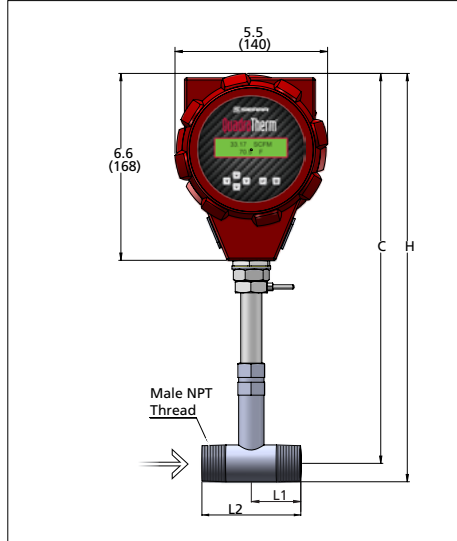

Sizes for 1-inch Through 8-inch NPT				
Size	H	C	L1	L2
2-inch	15.1 (384)	14.0 (356)	3.50 (89)	7.50 (191)
3-inch	15.7 (399)	14.0 (356)	4.00 (102)	10.00 (254)
4-inch	16.2 (411)	14.0 (356)	4.00 (102)	12.00 (305)
6-inch	17.3 (439)	14.0 (356)	6.00 (152)	18.00 (457)
8-inch	18.3 (465)	14.0 (356)	8.00 (203)	24.00 (610)

NPT Remote—Front View

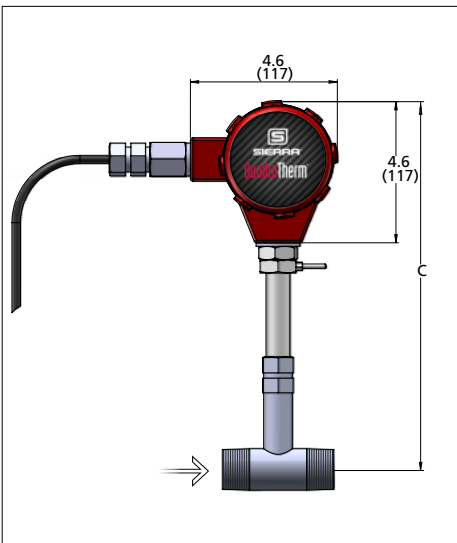

Flange Remote—Front View

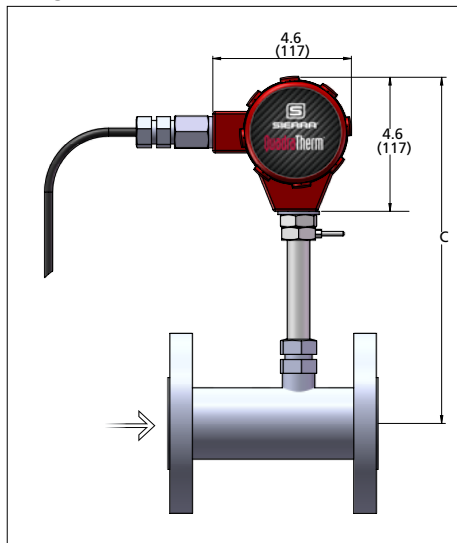

Sizes for PN16 DN Flanges				
Size	H	C	L1	L2
DN50	17.2 (437)	14.0 (356)	3.34 (85)	7.10 (180)
DN80	17.9 (455)	14.0 (356)	4.14 (105)	10.20 (259)
DN100	18.3 (465)	14.0 (356)	4.57 (116)	12.60 (320)
DN150	19.6 (498)	14.0 (356)	6.77 (172)	18.90 (480)
DN200	20.7 (526)	14.0 (356)	8.47 (215)	24.40 (620)

Feature 4B: Sensor Shield & Mounting Option Kits: Add 1-inch (25.4 mm) diameter stainless steel welded-on sensor shield to the end of the insertion probe for improved sensor protection.

S1()	This assembly includes a sensor shield and a captured Conax fitting 3/4-inch (19.1 mm) with 1-inch (25.4 mm) male NPT. Max pressure 400 psig (27.6 barg). Contact factory for 1000 psig (68.9 barg) option. Specify probe length in parenthesis
S2()	Assembly is a 1-inch (25.4 mm) Female NPT weldolet, which customer welds to the pipe. Commonly used with S1, Specify pipe O.D. in Parenthesis for S2. Max pressure 400 psig (27.6 barg). Contact factory for 1000 psig (68.9 barg) option.
S1-S2()	This assembly includes a sensor shield and a captured Conax fitting plus weldolet. 3/4-inch (19.1 mm) probe with 1-inch (25.4 mm) male NPT. Threads into 1-inch (25.4 mm) Female NPT weldolet, which customer welds to the pipe. Specify probe length in parenthesis for S1 and specify pipe O.D. in parenthesis for S2. Max pressure 400 psig (27.6 barg). Contact factory for 1000 psig (68.9 barg) option.
S1()-S8()	Low pressure hot tap assembly includes a sensor shield, a ball valve and packing gland with Conax fitting plus weldolet. Maximum 150 psig (10.3 barg). Retractor is required for greater than >150 psig (10.3 barg) if hot tapping (see S9 ()) Specify probe length in parenthesis for S1 and Specify pipe O.D. in Parenthesis for S8. The ball valve is one and a quarter inches vs our standard 1-inch m8 ball valve. This is so a hot tap tool can cut a 1 inch hole for the cage diameter.
S9()	High pressure hot-tap with removable retractor kit assembly includes a sensor shield, removable retractor assembly, packing gland probe seal with a 2-inch ANSI class 150 process connection (other classes available, contact factory), and Conax fitting. Specify probe length in parentheses, MINIMUM length is process connection dependent. Max pressure flange dependent or 400 psig (27.6 barg). Contact factory for 1000 psig (68.9 barg) option.

Feature 5: Electronics Enclosure

E2	Hazardous-area location enclosure NEMA 4X (IP66) mounted directly on probe
E4()	Remote hazardous-area location enclosure, includes NEMA 4 (IP66) junction box mounted on probe and mounting bracket for remote electronics enclosure; maximum 200 feet (61 m) housing mounted up to 200 feet (61 m) from flow body; specify cable length in parenthesis.

Feature 8: Display

DD	Digital Display: UltraBright LCD indicates mass flow velocity, T, P, alarms and totalized mass flow in engineering units; 6-push button user interface makes selection easy: Dial-A-Gas, Dial-A-Pipe, change units, change language, set alarms and much more...
----	--

Feature 6: Input Power

P2	24 VDC +/- 10.0%
P3	100-240 VAC

Feature 7: Output

V4	Two linear 4-20mA outputs for mass flow velocity and temperature
V6 (VTP only)	Three linear 4-20mA outputs for mass flow velocity, temperature and pressure (only available with Feature 1: Multivariable 640i VTP)

Feature 9: Pressure (VTP only)

MP1	30 psia (2.1 bara), VTP only
MP2	100 psia (6.9 bara), VTP only
MP3	300 psia (20.7 bara), VTP only
MP4	500 psia (34.5 bara), VTP only

Note: Put N/A in feature block 9 for VT or E4 meters. Maximum operating pressure must not exceed the full scale of the pressure transducer if the VTP option is ordered or damage may occur.

Feature 10: Dial-A-Gas (Air)

0	Air (+/- 0.75% of reading); Add three qTherm Dial-A-Gases, see Feature 11-13 below to choose additional gases (Default Gases: Nitrogen, Carbon Dioxide, Methane). You may choose qTherm calibration or actual gas calibration for each one of your three additional choices.
---	--

Feature 11-13 : qTherm Dial-A-Gas Selection

*Select three additional gases to be programmed into the instrument; Air is standard on the instrument and cannot be removed. qTherm gas is +/- 3.0% of full scale for all qTherm gases unless otherwise noted. Derated to 5% for 1" shroud option

qTherm Gas Code	Gas	Actual Gas Calibration Code
0	Air (standard)	0
1	Argon	1A
2	Carbon Dioxide	2A
3	Chlorine	N/A
4	Digester Gas	4A
6	Helium	6A
7	Hydrogen	7A
8	Methane	8A
10	Nitrogen	10A
11	Oxygen (0.75% reading plus 0.5% full scale qTherm accuracy)	N/A
12	Propane	12A
14	Ammonia ¹	NA
99	Other—Consult Factory	99

Option 1: Digital Communications

DP1	Profibus DP using an M12 connector, NAA only full device description (DC power only)
DP2	Profibus DP using a 2-wire terminal block connection with full device description (DC power only)
FF	Foundation Fieldbus full device description
MB	Modbus RTU full device registers
HART	HART with full device description

Note: Available with cFmus and ATEX/IECEx except DP1.

¹Correlation calibration - consult Gas Table for accuracy.

Feature 9: Dial-A-Gas (Air)

0	Air (+/- 0.75% of reading); Add three qTherm Dial-A-Gases, see Feature 11-13 below to choose additional gases (Default Gases: Nitrogen, Carbon Dioxide, Methane). You may choose qTherm calibration or actual gas calibration for each one of your three additional choices.
----------	--

Feature 10-12 : qTherm Dial-A-Gas Selection

*Select three additional gases to be programmed into the instrument; Air is standard on the instrument and cannot be removed. qTherm gas is +/- 3.0% of full scale for all qTherm gases.

qTherm Gas Code	Gas	Actual Gas Calibration Code
0	Air (standard)	0
1	Argon	1A
2	Carbon Dioxide	2A
3	Chlorine	N/A
4	Digester Gas	4A
6	Helium	6A
7	Hydrogen	7A
8	Methane	8A
10	Nitrogen	10A
11	Oxygen (0.5% reading plus 0.5% full scale less than 50% qTherm accuracy)	N/A
12	Propane	12A
14	Ammonia ¹	NA
99	Other ¹ —Consult Factory	99

Option 1: Digital Communications

DP1	Profibus DP using an M12 connector, NAA only full device description
DP2	Profibus DP using a 2-wire terminal block connection with full device description
FF	Foundation Fieldbus full device description
MB	Modbus RTU
HART	HART with full device description

Note: Available with cFMus and ATEX/IECEx except DP1. P2 only.

¹Correlation calibration - consult Gas Table for accuracy.

Customize Your Flow Tools.

Buy Online Today or Request a Quote!

How to Buy Online QuadraTherm 640i Units:

Visit <http://sierrainstruments.com/shop/640i>

How To Request A Quote QuadraTherm 640i/780i Units:

Visit <http://sierrainstruments.com/getquote/quadratherm>

BUY
ONLINE

In Stock Products. Ship In Two Days.*

<https://sierrainstruments.com/shop>



*Disclaimer: Dependent on availability of stock.



SIERRA®

sierrainstruments.com

NORTH AMERICA

5 Harris Court, Building L / Monterey, CA 93940 / USA
800.866.0200 / 831.373.0200 / fax 831.373.4402

EUROPE

Bijlmansweid2 / 1934RE Egmond aan den Hoef / The Netherlands
+31 72 5071400 / fx +31 72 5071401

ASIA-PACIFIC

Second Floor Building 5 / Senpu Industrial Park
25 Hangdu Road Hangtou Town / Pu Dong New District
Shanghai, P.R. China Post Code 201316
+8621 5879 8521/22 / fx +8621 5879 8586