

S-PLUR SMART LINE OPERATION MANUAL

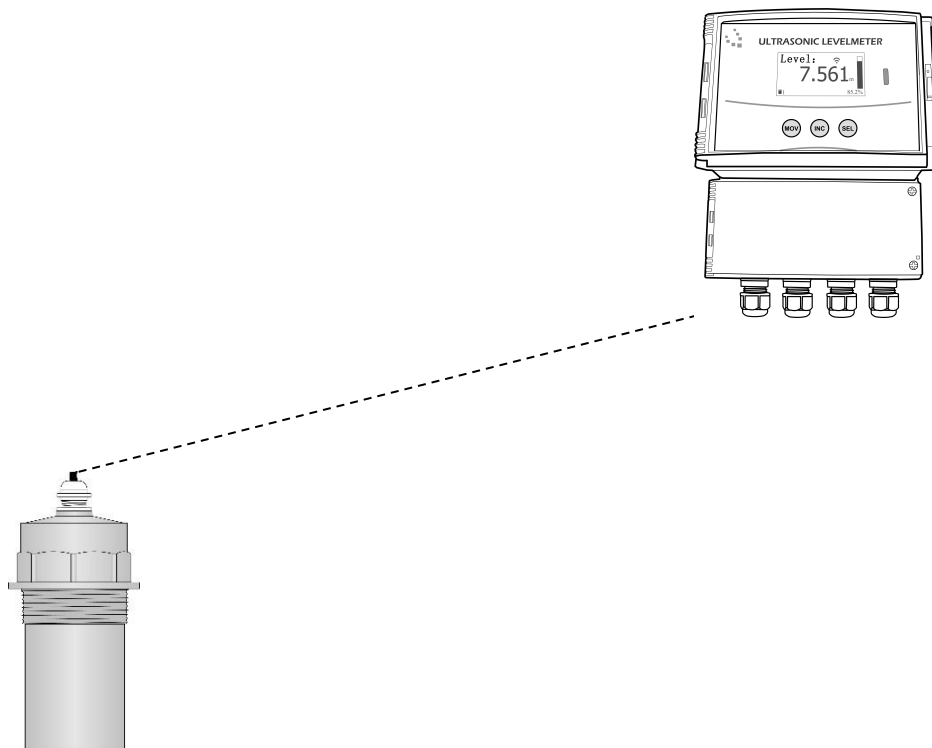

CONTENT

1. Introduction	- 3 -
1.1 Application.....	- 3 -
1.2 Features.....	- 3 -
1.3 Structure.....	- 3 -
1.4 Measuring principle: Time-of-flight method.....	- 4 -
1.5 Technical Data.....	- 5 -
2. Installation	- 7 -
2.1 Installation Considerations.....	- 7 -
2.2 Mounting Dimensions.....	- 8 -
3. Wiring	- 10 -
3.1 The host.....	- 10 -
3.2 Wiring Diagram.....	- 10 -
3.3 The Cable.....	- 11 -
4. Operation	- 12 -
4.1 Display and Keys.....	- 12 -
4.2 Two working mode.....	- 12 -
5. Calibration	- 20 -
5.1 General consideration.....	- 20 -
5.2 Serial communication-Modbus-RTU.....	- 21 -
Address number.....	- 21 -
Baud rate.....	- 21 -
Parity Check.....	- 21 -
Function code.....	- 21 -
Abnormal corresponding.....	- 22 -
Electrical connection.....	- 22 -
The RTU mode.....	- 22 -
6. Trouble-shooting	- 25 -

1. Introduction

1.1 Application

The S-PLUR series is an enhanced remote ultrasonic level meter for continuous non-contact level measurement in liquids and solids. It consists of probe and host, both of which are plastic leak-proof structure. This series can be widely applied to the metallurgical, chemical, electricity and oil industries.

1.2 Features

S-PLUR series is capable of the following functions:

- Measuring range up to 40m (in liquid);
- Excellent anti-interference capability;
- Clear display with Graphical LCD(with backlight) ;
- The cable length between probe and host up to 1000m;
- The probe with leak-proof structure and IP68 protect grade;
- Chemically resistant probe materials for maximum application flexibility;
- Provided 4-20mA output and RS485 serial communication (MODBUS-RTU) output;
- Provided programmable 6 relays at most for alarms;
- Three button for programming or remote control for easy configuration and operation (opt.) ;

1.3 Structure

The S-PLUR series consists of a probe and a host. The remote control is optional.

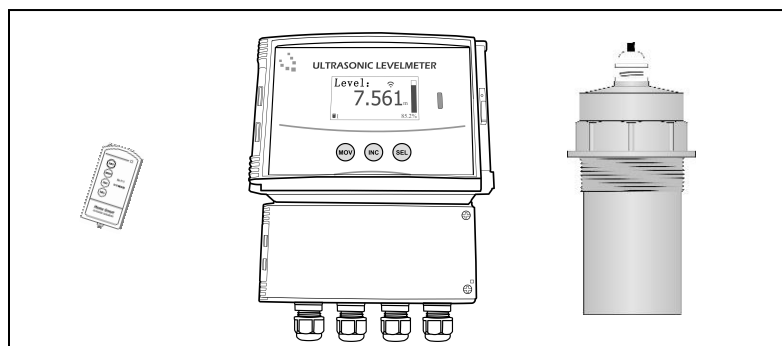

1.4 Measuring principle: Time-of-flight method

The probe is mounted on the top of the flume, and ultrasonic pulses are transmitted by the probe to the surface of the monitored material. There, they are reflected back and received by the probe. The host measures the time t between pulse transmission and reception. The host uses the time t (and the velocity of sound c) to calculate the distance d between the sensor bottom and the monitored liquid surface: $d = c \cdot t / 2$. As the host knows the installation height H from parameters setting, it can calculate the level as follows: $h = H - d$.

Since speed of sound through air is affected by changes in temperature, the S-PLUR has integrated a temperature sensor to improve accuracy.

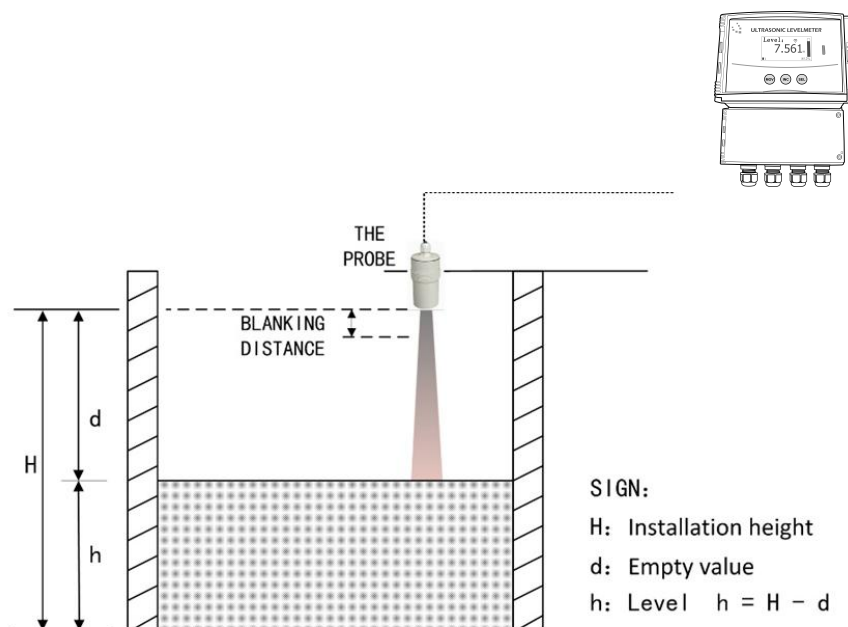

An integrated temperature sensor compensates for changes in the velocity of sound caused by temperature changes. Calibration Enter the empty distance H and the span F to calibrate the device.

Blind zone: Level echo from the blind zone cannot be evaluated due to the transient characteristics of the sensor. Span F may not extend into the blanking distance B .

1.5 Technical Data

1.5.1 The host

Type	
Power supply	DC24V ($\pm 5\%$) 0.2A; AC220V ($\pm 20\%$) 0.1A
Display	Graphical LCD
Resolution	1mm
Analogue output	4-20mA
Relays outputs	6 multi-function SPDT relays at most (optional) , rated 5A /250VAC/30VDC, high, low and failsafe alarm and control corresponding to level or distance values .
Serial communication	RS485, MODBUS-RTU standard protocol
Ambient temperature	-20°C~70°C
Temperature compensation	Integral in probe
Pressure range	± 0.1 MP (press definitely)
Measure cycle	1 second (changeable)
Parameter setting	3 induction buttons / remote control
Cable gland	PG9 /PG11/ PG13.5
Material	ABS
Protect grade	IP67
Fix	Hang
Dimensions	248H*184W*122D(mm)

1.5.2 The probe

- L-4、L-6、L-8 Technical data

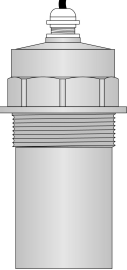
	Measuring range	L-4:0-4m blacking distance:20cm L-6:0-6m blacking distance:25cm L-8:0-8m blacking distance:30cm
	Temperature range	-40℃~80℃
	Pressure range	±0.1MP (press definitely)
	Beam angle	8° (3db)
	Material	ABS/PVC/PTFE
	Protect grade	IP68
	The length of cable	10m(standard)
	Fix	Flange /screw

- L-12 L-20、L-30、L-40 Technical data

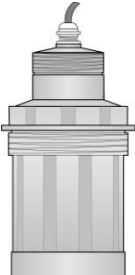
	Measuring range	L-12:0-12m blacking distance:50cm L-20:0-20m blacking distance:80cm L-30:0-30m blacking distance:100cm L-40:0-40m blacking distance:120cm
	Temperature range	-40℃~80℃
	Pressure range	±0.1MP (press definitely)
	Beam angle	5° (3db)
	Material	ABS/PVC/PTFE
	Protect grade	IP68
	The length of cable	10m(standard)
	Fix	Flange/screw

2. Installation

Reasonable installation is critical factor of the instrument's normal working. Installation must be carried out by trained person in accordance with the manual.

2.1 Installation Considerations

2.1.1 Hints for the host mounting

- The host should not be mounted in a confined space where temperatures may exceed the normal working temperature (-20~+70), if the host is mounted outside, it must be protected from direct sunlight or severe weather conditions.
- Ensure that the mounting surface is not subject to vibration and is not in close proximity to high voltage cables, contactors or drive controls.
- Select appropriate knockouts in the base of the enclosure and fit appropriate cable glands to maintain the IP67 rating.
- Do not use excessive force when tightening the fixing and avoid any distortion of the enclosure.
- Pay attentions to the dimensions of the host and the enclosure.

2.1.2 Hints for probe mounting

- The probe can be supplied as standard or with a screw nut or with an ordered flange.
- For applications requiring chemical compatibility the probe is available fully enclosed in PTFE.
- The use of metallic fittings or flanges is not recommended.
- For exposed or sunny locations a protective hood is recommended.
- Make sure that the probe is mounted perpendicular to the monitored surface and ideally, at least 0.25 meters above it, because the probe cannot get response in the blind zone.
- The probe has a 10 inclusive conical beam angel at 3 db and must be mounted with a clear unobstructed sight of the liquid to be measured. But smooth vertical sidewalls weir tank will not cause false signals.
- The probe must be mounted upstream of the flume or weir.
- Do not over-tighten the bolts on flange.

2.2 Mounting Dimensions

● The host

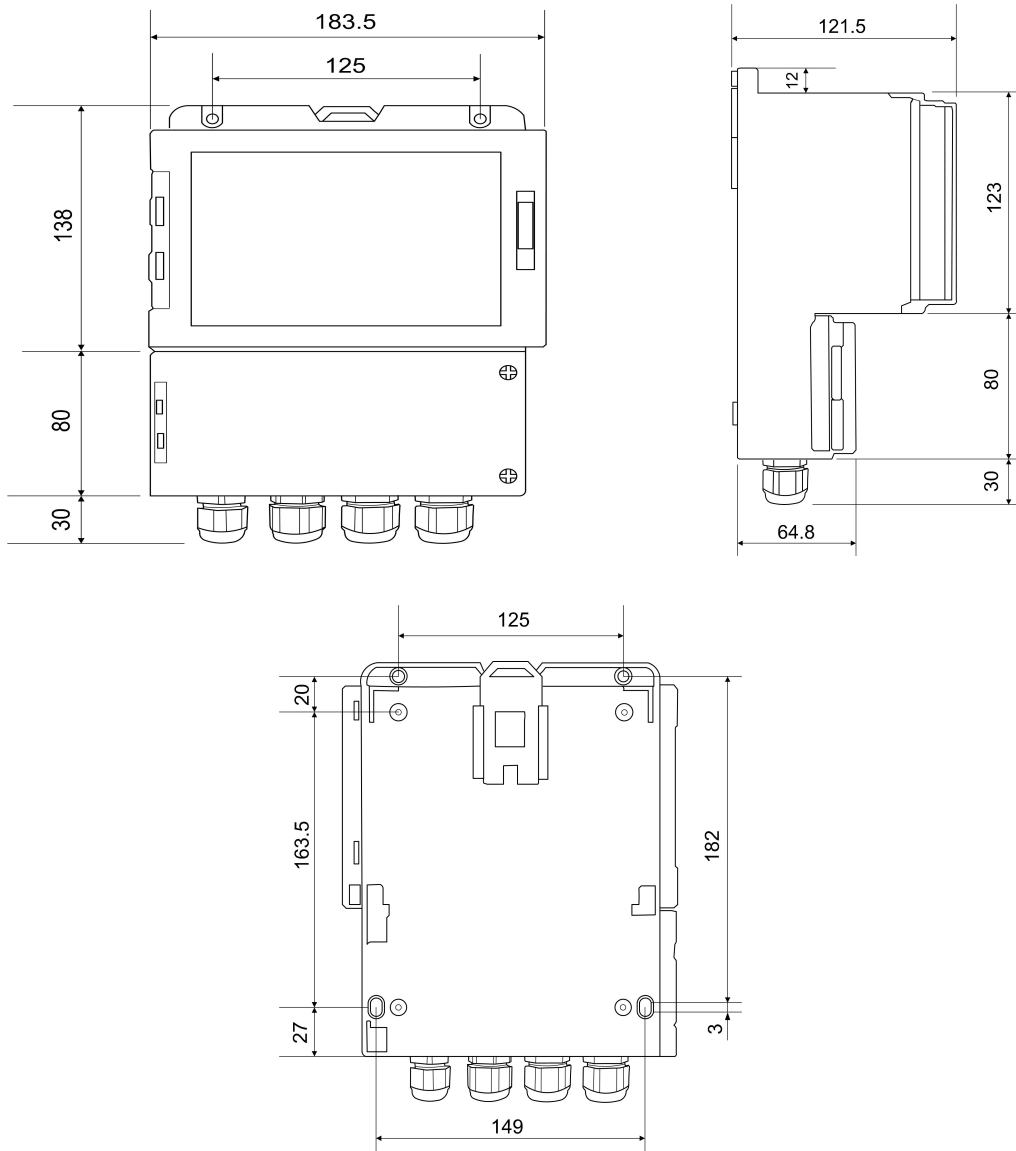

- The probe

4m、6m、8m

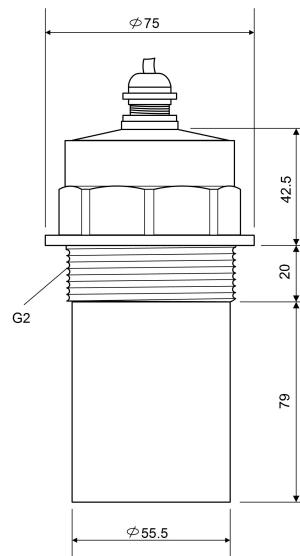

12m 20m、30m、40m

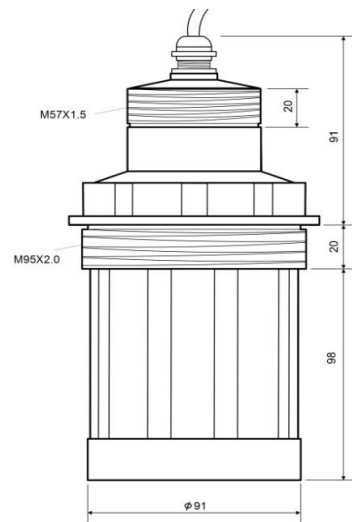

- The remote control

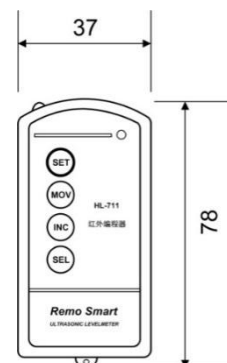

3. Wiring

The S-PLUR series has one LCD show and three keys for setting and some terminal blocks, which are located within the host housing and can be operated when the terminal cover is open.

3.1 The host

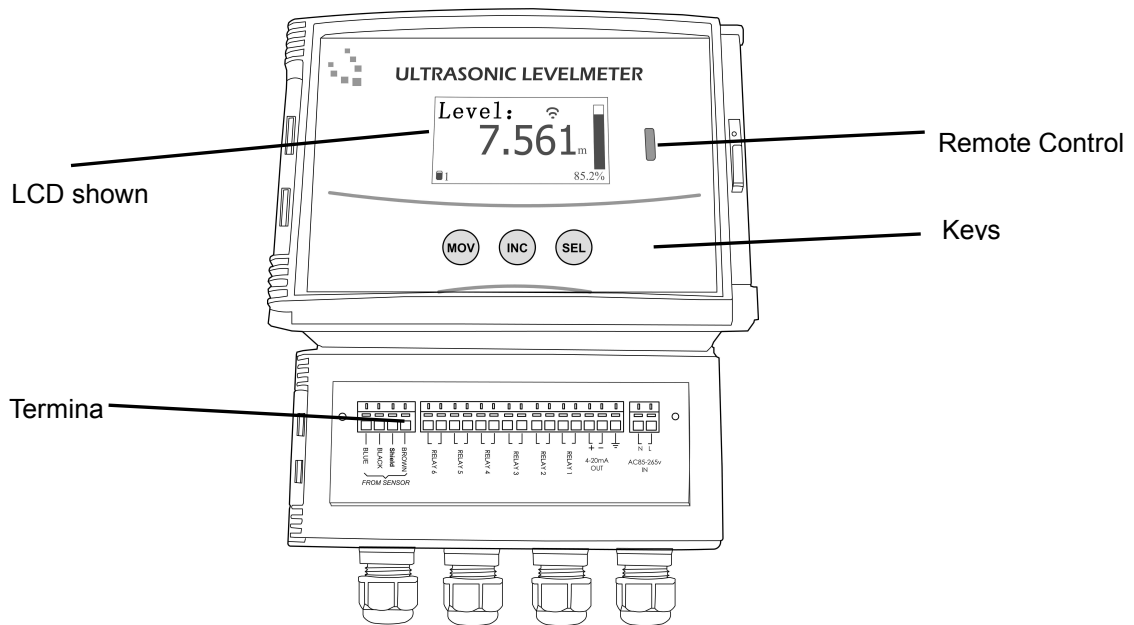

3.2 Wiring Diagram

Remove the terminal cover to expose the terminals shown below. The wiring instructions are on bottom of the terminals as below.

- DC24V power supply

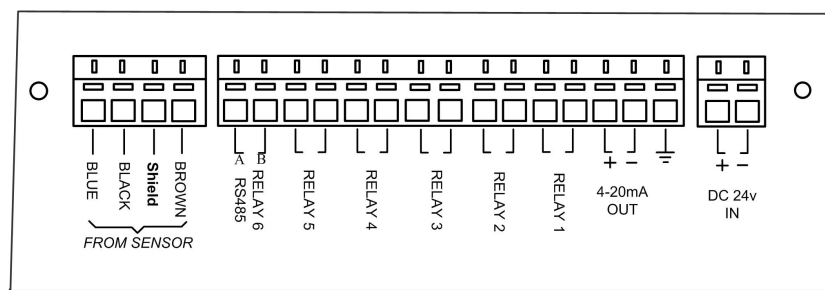

- AC220V power supply

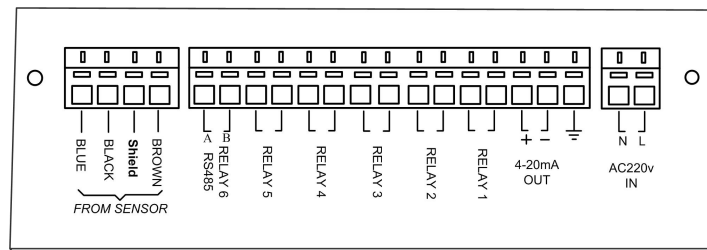

NOTES: The connection maybe different according to the different power supply and signal output.

When the RS485 serial communication function is provided, the relays can be provided with 5 pcs at most.

Carefully confirm the marked power supply terminals, to ensure the correct power supply connection.

3.3 The Cable



The cable between probe and host is 10m standard. Users can extend the cable when desired, and the max distance between probe and host is 1000m.

The cable with three core shield wire is recommended.

4. Operation

4.1 Display and Keys

The S-PLUR series is displayed with the Graphical LCD, and it has three keys, with its functions as follow:

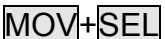
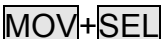
Keys	Functions
	<ol style="list-style-type: none"> 1: Go into the next level menu or program 2: Saves the current Settings 3: Switch the measurement page
	<ol style="list-style-type: none"> 1. Select the menu from up to down in turn; 2. Adjust the parameters of a particular value (0 ~ 9)
	<ol style="list-style-type: none"> 1. Cycle select other parameters 2. Cycle select other digit of a value.
 Short Press	<ol style="list-style-type: none"> 1. Go from the running Mode into the programming Mode. 2. Exit from the setting program to the last menu, or return the Main Menu to the Running Mode.
 Long Press 6 seconds	Restart the instrument.

4.2 Two working mode

The instrument has two working mode: running mode and programming mode. In running mode, the measurement data is displayed. In programming mode, user can setup parameters of the instrument.

4.2.1 Running mode

When the power is turned on, the instrument takes several seconds to initialize and then runs into the running mode to start the normal level measurement.



In the running mode, the level meter shows the level measurement, in which the state contains 2 pages: the **main measuring page** and **other measurement information page**, press  key to quickly switch two pages. The **main measuring page** can display the level value/distance

value, the sensor state, the bar chart, and the relay state. Other information pages can display the distance value, probe temperature and output current.

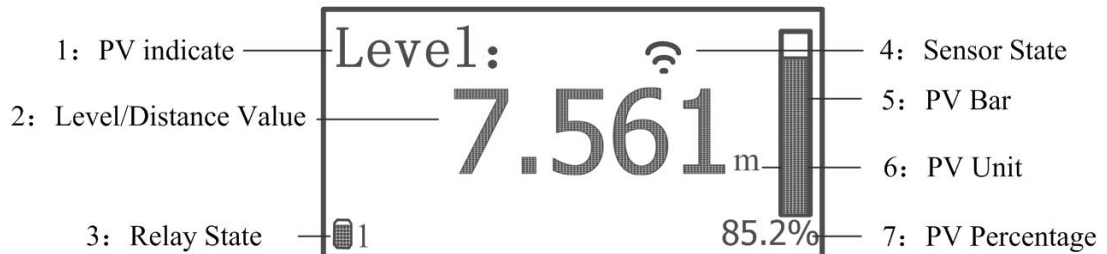
The main measurement page (display content sample is as follows):



Graphic description:

- 1 **PV indicator:** indicator is the main variable is the Level or Distance(depends on the setting), current output corresponding to it.
- 2 **Level/Distance value:** real-time display of the current instantaneous level value/Distance value, decimal point position is automatic adjustment.
3. **Relay state:** When an alarm condition is reached according to the relay setting, 1-6 high or low relay alarm icon would be shown here.
4. **The sensor status:**  flashing show host and probe communication is normal, and the echo is normal.  icon shows probe has no echo.  icon shows the host couldn't detect the probe.
5. **PV bar:** PV bar chart corresponding to PV value.
6. **PV units:** Display PV unit (m/ft) , can be modified in the Settings.
7. **PV percentage:** The PV percentage.

Relay Alarm display:



Relay 1,3 achieve high operating point setting (high alarm)



Relay 2 reaches the low operating point (low alarm)

Other measurement information page (display content sample is as follows):

In the main measurement page press the **SEL** button to enter into other measurement information page, press **SEL** button again to return to the main measurement page or it will automatically return to the main measurement page after 60s.

DIST.:	0.473m
TEMP:	21.4°C
Curr:	17.5mA

This page shows the probe temperature (°C), output current (mA), the distance value (m / ft can be changed in settings).

Note:

- If the PV is select as level value, the installation height (H) must be set NO less than (\geq) the measured distance (D) value. If H is less than D, then the PV Value and the words “Level” in the main measurement page will keep flashing; except the distance value on the other measurement information page, the level value and the output current will not change.
- The S-PLUR series can provide 6 relays which may be used for control purposes. These relays are for light duty and should be used as signal relays only, with control functions being performed by external control relays.

4.2.2 Programming mode

In programming mode, user can setup parameters of the instrument.

In this state, the instrument displays the parameters set by the user's needs. In the measurement mode user pressing **SEL**+**MOV** together in short to enter the the main menu of the programming mode.

Press **INC** to choose item down in cycle in menu.

Press **SEL** to enter the next level menu or program

Press **SEL** + **MOV** together in short to go back to the upper level menu, or quit.

This instrument uses two level menu structure, menu structure is as follows:

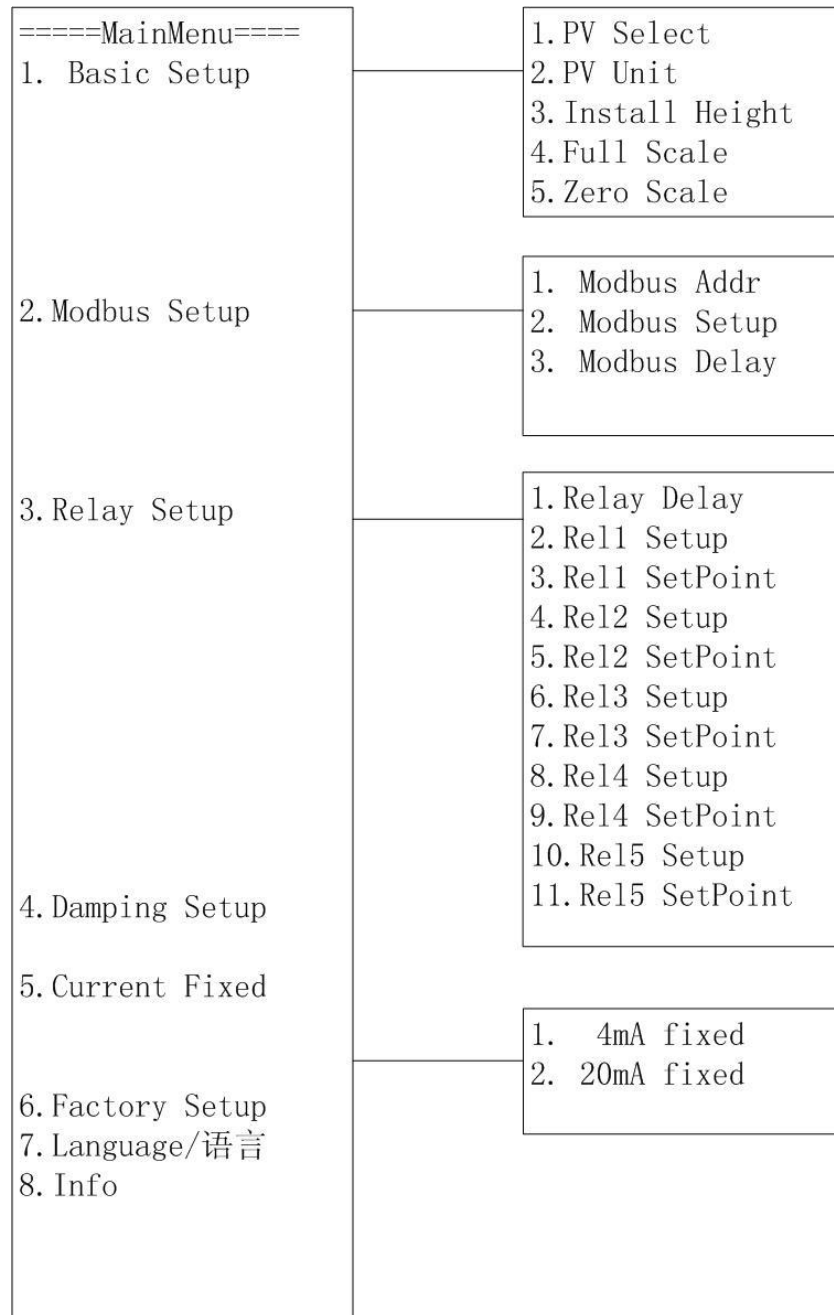



Parameter modification operation

When parameters are modified, the upper right corner of the screen will appear, prompt parameter has been changed, but not save. If press the **MOV** + **SEL** to exit, instrument will not save the changes. If want to save the setting, press the **SEL** button icon shows the modified setting have been saved. Then press **MOV** + **SEL** exit to the upper menu.

Basic setup

After finish this part , the basic function of level-meter would work

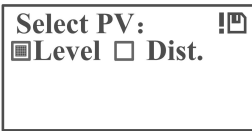
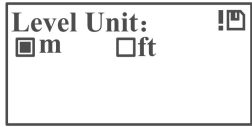
normally.

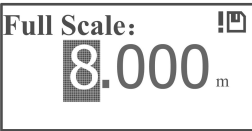
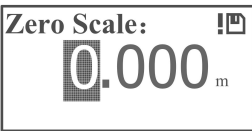
Basic Setup	1.PV Select		Press MOV , select PV from Level or Distance.Change affects measurement information Page, and the current output corresponding to it.
	2.Level Unit		Press MOV , switching between m and ft. (the default unit is m) Change affects measurement information Page, and change all the Settings about the level or distance values.
	3.Install Height		From the probe emission surface to the lowest liquid/solid level. Unit depends on the level unit settings.
	4.Full Scale		The PV value(level/distance value) corresponding to 20 mA output current (Unit depends on the level unit setting,the number of digit depends on the sensor type)
	5. Zero Scale		The PV value(level/distance value) corresponding to 4 mA output current (Unit depends on the level unit setting,the number of digit depends on the sensor type)

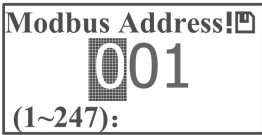
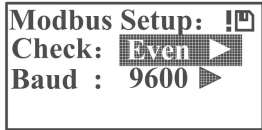
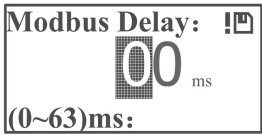

Modbus Setup

After finish the part MODBUS setting ,communication function can be normal use.

Modbus Setup	1.Modbus Address		Address 1 ~ 247 is valid (default:001)
	2.Modbus Setup		Press INC select between Check and Baud. Press MOV right change the parameter in cycle. Check: None (8n1) /None (8n2) /odd/Even (Default) Baud Rate: 1200 / 2400 / 4800 /9600(Default)/19200
	3.Modbus Delay		Modify the Modbus delay time, make some host communication compatibility. 0 ~ 63 ms is valid , Default 0 (ms)

Relay setting

If you want to use the relay, first set relay (1 ~ 6) setup and then configure the corresponding relay action points, the corresponding relay can work properly.

Relay Setting	1.Relay Delay		Change the relay delay time Relay delay action after reaching the set value of relay set point, so as to avoid fluctuations in the level, can be modified (0-99s) (Default 5s)
	4.Relay 1Setup (Relay1~6Setup is same here)		Press INC switch from the Enable , NC/NO AND Type. Press MOV change the setting . Enable: Yes/No(Default) NC/NO(normal close /normal open): NO(Default)/NC Type : High Alarm (Default)/Low Alarm/Fail Alarm (When there is no

			echo or lost the sensor)
	<p>5.Relay1 Set Point (Relay 1~6 Set point Setting is same here)</p>		<p>According to the corresponding relay parameter PV value is greater than or less than this value, the relay 1-6 action, on or off,determined by the corresponding parameters of the relay.</p> <p>(When set to Fail Alarm the value is invalid, the unit depending on the level unit, the integer digits depending on weir type)</p>

Damping Setup:

Increase the damping value can stable the level/distance value result, but can make the instrument response slowly, and vice versa.

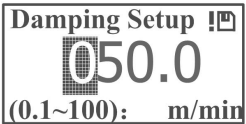
	Damping Setup		<p>Ranging from 0.1~100m/min default:50m/min</p>
--	---------------	---	---

Current Fixed

Under special circumstances, the instrument has a larger error between actual output current and display current, the instrument need to do current fixing. (The factory has been set to optimal values , do not need to modify)

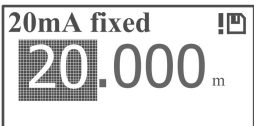
Current Fixed	4mA fixed		<p>After connecting to the ammeter, the instrument will output no fixed 4 mA current, you need to input actual ammeter readings and then press SEL, instrument would calibration automatically, repeat the steps until the output current is 4.0 mA.</p> <p>Press SEL + MOV to quit</p>
	20mA fixed		<p>After connecting to the ammeter, the instrument will output no fixed 20 mA current, you need to input actual ammeter readings and then press SEL, instrument would calibration automatically, repeat the steps until the output current is 20.0 mA.</p> <p>Press SEL + MOV to quit</p>

Factory Setup

Instrument internal parameter adjustment, the user does not have to set the value, do not enter into the state of internal work parameter Settings.

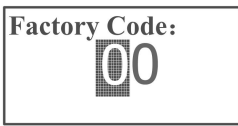
	Factory Code		<p>Input the correct values, the instrument would enter into the state of Factory parameter Settings. The user does not have to set this value, do not enter into the state of internal work parameter Settings.</p>
--	--------------	---	--

Language Settings:

If need to change other language, enter the option to choose.

	Language /语言		Switch the system Language : Chinese /English
--	--------------	---	---

Info

Instrument Info

	Info		display instrument type and the connected probe type.
--	------	---	---

Notes:

- Push the buttons firmly, but not too hard, to avoid damaging the circuit boards.
- When the instrument is used for pump control, please avoid to directly connect the relays to pump power supply circuit.
- When there is RS485 serial communication, the relay No.6 is invalid.
- The remote control can also be used to configure the parameters.

There are four keys **SET**、**MOV**、**INC**、**SEL**. **MOV**、**INC** and **SEL** three keys have same functions as they are in the host panel. **SET** key is the same function of **MOV** **SEL** press together in short .

5. Calibration

The instrument should be calibrate indoor before installation to ensure the normal performance.

5.1 General consideration

- Let the probe be perpendicular to a wall, and make sure the measuring distance is larger than the blacking distance, and no barriers within the beam angle zone.
- Wiring and connecting the instrument correctly according to the guide .
- Turn on the power and after a few seconds the instrument will enter the running mode. Check the level value, sensor state, and press **SEL** key to check liquid level value , distance value and temperature value.
- Move the probe slowly , the level value and distance value should change slowly accordingly.

- Press **SEL** and **MOV** keys simultaneously in short and then enter the Programming mode. Adjust installation height, then the instantaneous level value should change accordingly.
- Adjust the full scale in the basic setting, and test the output current with a multi-meter, the output current should change, too. Because the output current is always in accordance with the level value/ distance value.
- Adjust the status of relays, and test with a multi-meter if the relays working on the right condition.
- If the instrument has RS485 serial communication function, it should be tested with the host computer online.

5.2 Serial communication-Modbus-RTU

The serial communication is optional for HLML, with standard Modbus protocol, RTU serial transmission mode. (This function should be confirmed when it is ordered.)

Address number

The valid address numbers are in the range 1-247, and the address number is corresponding to the address code in Modbus communication. It can be set in the programming mode.

Baud rate

This series allows the following baud rate(RTU mode): 19200bit/s, 9600bit/s, 4800bit/s,2400bit/s,1200bit/s. .The baud rate can be set in the programming mode.

Parity Check

Three check modes: Odd parity 、 even parity , no parity(8n1) and no parity(8n2) . The check mode can be set in the programming mode.

Function code

According to the specific application of this instrument, only one function code "03" is used, to read the read holding registers. Other Modbus function code is not valid in this instrument.

Abnormal corresponding

According to the specific application of this instrument, three abnormal data are supported in the RTU mode.

- 01: false function
- 02: false data address
- 03: false data

Electrical connection

The instrument supports the EIA/TIA-485 standard 2-wire communication link.

This instrument does not require polarity of the bias circuit.

The cable is suggested to be a pair of balanced twisted-pair cable, and shielded cable is best. When the baud rate is 9600bit / s, maximum length of the cable (AWG26 specification and above) is 1000m.

The RTU mode

The RTU frame format: the representation of data is hexadecimal byte. Each byte has 11 bits: 1 start bit, 8 data bits, 1 parity check bit, 1 stop bit, 2 stop bits when without parity check.

1) The master request:

1	2	3	4	5	6	7	8
Slave Address	0x03	Starting register high byte	Starting register low byte	number of registers to read high byte	number of registers to read low byte	CRC Check High	CRC Check Low

1 :Slave Address:Slave address range (001 ~ 247)

2 :0x03: function code of read keep register

3, 4: : The starting register

5, 6: number of registers to read

7, 8 : CRC check

2) The slave response :

1	2	3	4、5	6、7		M-1、M	M+1	M+2
---	---	---	-----	-----	--	-------	-----	-----

Slave Address	0x03	Data Count	Register Data 1	Register Data 2	Register Data M	CRC Check High	CRC Check Low
---------------	------	------------	-----------------	-----------------	-------	-----------------	----------------	---------------

- 1 :Slave Address:Slave address range (001 ~ 247)
- 2 :0x03: function code of read keep register
- 3 : Data count.
- 4, 5: Register Data 1
- 6,7: Register Data 2
- M-1,M: Register Data M
- M+1, M+2 : CRC check

3) The Modbus Table:

Function 0x03 Read Holding Register

Register Address	Data Form	
0x0000	Unsigned int (16bit) 1 WORD	Instantaneous level value Unit is mm
0x0001	Unsigned int (16bit) 1 WORD	Instantaneous distance value Unit is mm
0x0002	signed int (16bit) 1 WORD	temperature Unit °C

Example:

1.Read the level value

Host: 0x01 0x03 0x00 0x00 0x00 0x01 0x84 0x0A

Slave: 0x01 0x03 0x02 0x15 0xFA 0x36 0x97

Level value :0x15FA (5626mm)

2.Read the distance value

Host: 0x01 0x03 0x00 0x01 0x00 0x01 0xD5 0xCA

Slave: 0x01 0x03 0x02 0x09 0x46 0x3F 0xE6

distance value :0x0946 (2374mm)

3.Read the level value,distance value and temperature value .

Host: 0x01 0x03 0x00 0x00 0x00 0x03 0xB2 0x49

Slave: 0x01 0x03 0x06 0x15 0xFA 0x09 0x46 0x00 0x11 0xD9 0xE1

Level value :0x15FA (5626mm)

distance value :0x0946 (2374mm)

temperature value :0x0011 (17°C)

6. Trouble-shooting

Trouble Phenomenon	Trouble Reason	Solution
The instrument does not show, and does not work.	Power supply error. Wiring error.	Check the power supply. Check the wiring.
The instrument doesn't work but with show.	The sensor doesn't aim at the liquid or the material. The surface has great fluctuations. Liquid surface with lots of foam. The container is empty and the bottom is not flat. Over the range.	Adjust the sensor and aim at the material. Add a tube to the container. Add a tube to the container. Use instrument with a lager range. Use instrument with a lager range.
The instrument shows unstable or the measured value has a great deviation.	The level enters the blanking distance. There is strong electromagnetic interference There is Obstruction of the ultrasonic wave.	Increase the installation height of the instrument, or prevent the level too high. Increase shielding to the instrument. Change the installation site or using a plastic tube.