

Metal Tube Rotameter

User Manual

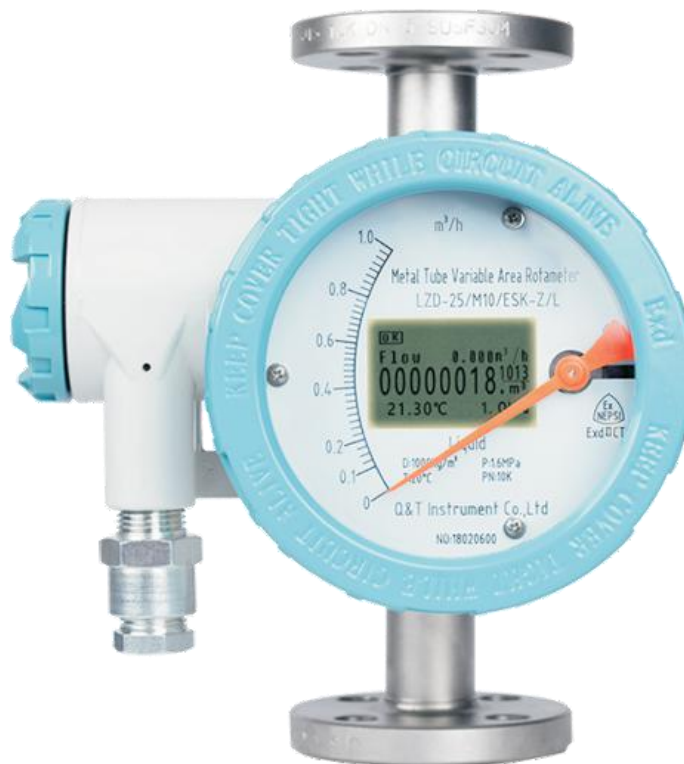

(Version 21)

CONTENTS

1. Safety Instructions.....	1
2. Introduction.....	3
2.1 General Description.....	3
2.3 Features.....	4
2.4 Drawing.....	5
2.5 Technical Parameters.....	9
3. Intended Use.....	10
4. Wiring.....	12
5. Limit Switch	15
6. Flow Table.....	17
7. Operation.....	19
7.1 Main Parameters.....	19
7.2 Clear Total Flow.....	20
7.3 4 mA correction.....	21
7.4 20 mA Correction.....	22
7.5 Flow Unit.....	23
7.6 Damp.....	24
7.7 Small Signal Cutoff.....	25
7.8 Measuring Range.....	26
8. Trouble Shooting.....	27

1. Safety Instructions

Thank you for purchasing our product.
 We have written this guide to provide the persons responsible for the installation, operation and maintenance of your flow meter with the product specific information they will need.
 In order to prevent damage to instrument and make the instrument in the best performance and stable operation, please read this manual thoroughly before installation.

Please have a safekeeping of this manual and together with the instrument after reading.
 Please pass this manual to technical department of end user to keep.
 This manual classifies important grade of safety attentions by Caution and Warning.





Caution

Error operation in case of ignoring the tips might cause the personal injury or damage to the instrument and property.



Warning

Error operation in case of ignoring the tips might cause the personal injury or major accident.

This manual contents the following icons:	
	Indicates safety attentions which are dangerous.
	Indicates safety attentions which are needed to pay attention to.
	Indicates safety attentions which are forbidden.



Select explosion-proof instrument for explosive environment application

Confirm whether the nameplate of instrument has the identifiers of explosion-proof certification and temperature class, the instrument can't be used in explosive environment without those identifiers.



The explosion-proof temperature class of instrument must meet the explosion-proof and temperature of environmental requirements on site

When the instrument is in used explosion-proof environment, make sure that the explosion-proof certification and temperature class of instrument meet to the



requirements on site.



No opening while working in explosive environment

Before wiring, please power instrument off.



The protection class of instrument must meet the working condition requirements on site

The requirement of protection class on site should be under or the same as the protection class of instrument to ensure that the instrument is working fine.



Confirm the working environment of instrument and medium temperature

The environment on site and the maximum medium temperature should be under the nominal value of instrument.



Confirm the ambient pressure of instrument and medium pressure

The ambient pressure on site and the maximum medium pressure should be under the nominal value of instrument.



If doubting that the instrument in the event of failure, please do not operate it

If there are something wrong with the instrument or it had been damaged, please contact us.



Important

Before use, read this manual thoroughly and familiarize yourself fully with the features, operations and handling of rotameter to have the instrument deliver its full capabilities and to ensure its efficient and correct use.



Warning

When using a metal tube rotameter, the total system design must be considered to ensure safe and troublefree performance. Function, material compatibility, adequate ratings, proper installation, operation, and maintenance are the responsibilities of the system designer and user. Improper selection or misuse of the product may result in serious personal injury or property damage.

Information

Metal Tube Rotameter may be used only for flow measurements of fluid and gaseous media. The manufacturer shall not be liable for damages that may result from unintended or inappropriate use.

When dealing with an aggressive medium, clarify the material resistance of all wetted parts.

When using the device in hazardous areas, follow the applicable national installation rules.

Caution

Installation, start-up and operating personnel

Only trained specialists authorized by the system operator may carry out the installation, electrical installations, startup, maintenance and operation. They must read and understand the operating manual and follow its instructions.

The required mounting, electrical installation, start-up and maintenance work may only be carried out by expert and authorized persons designated by the plant operator. Basically, follow the conditions and provisions applicable in your country.

2. Introduction

2.1 General Description

LZ Series intelligent Metal tube rotameter is a variable area flow meter which is based on the float position measurement. With full-metal structure, it has the features of small size, low pressure loss, large range ratio (10~20:1), optional transmitter with HART communication function, and convenient installation & maintenance etc. It is widely used in flow measurement and process control of small flow, low flow rate, and various industries under complex and harsh environments.



2.2 Working Principle

The flow meter consists of a measuring tube and a float inside it. The flow pushes the float to an equilibrium point. The area obtained between the float and the tube is proportional to the flow rate.

The point of equilibrium depends on:

- E = Force of the fluid flow
- F_f = Weight of the float
- A_l = Free area of flow

where:

$$A_l = A_0 \text{ (calibrated orifice area) } - A_f \text{ (float area)}$$

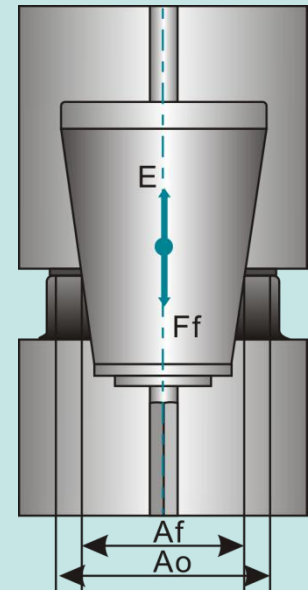

2.3 Features

1. Robust all-metal structure design.
2. Suitable for gas and liquid measurement in various industries.
3. Cone-shape measuring tube design, which has wide measuring range and good linearity.
4. Wetted parts material are optional: Stainless steel, Titanium, Hastelloy, PTFE, FEP, etc.
5. Adopt advanced magnetic coupling system design, improve the accuracy and stability
6. The upper row displays the instantaneous flow, the lower row displays the total flow

Instantaneous flow	0.000-99999
Total flow	0.00-99999999
Current range	3.80-21.00mA
Instantaneous flow percentage	0-100%
Pointer angle	0.00-90.00°
Ambient temperature	-40-- +150°C
Total flow small signal cutoff	0-10%
Damping time setting range	0-10 seconds

Various flow units are optional, the range is automatically converted when unit is changed.

- 7. For the digital LCD display type, the flow range of the instantaneous flow can be corrected on-site based on the different measuring medium.
- 8. It adopts advanced six level data backup technology, data of total flow can be saved automatically when power-off, (the total flow sending period is 0.3S).
- 9. Besides AC/DC power supply, it supports battery power supply function.
- 10. No need to open the cover, it can be operated by a magnetic pen; the key operation function is also available.
- 11. Through the HART protocol, you can use the handheld operator or host computer software to perform partial or full configuration operations on the flowmeter.

2.4 Drawing

- **Standard Dimensions and Weight**

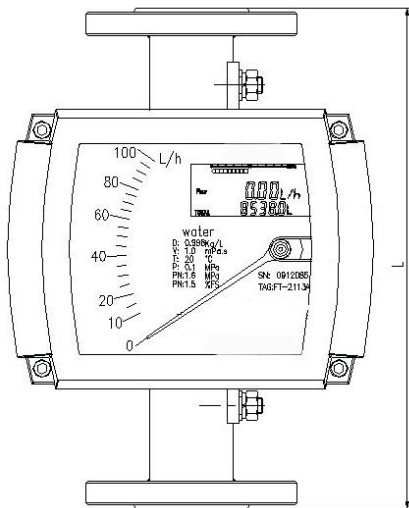

Square Convertor

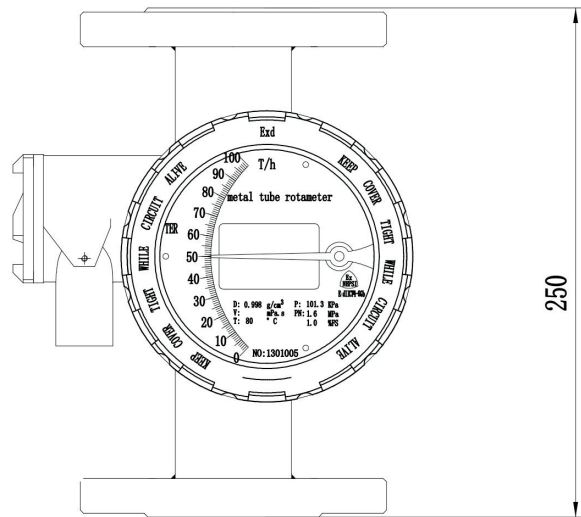

Round Convertor

Caliber	DN15	DN25	DN50	DN80	DN100	DN150
L (mm)	250	250	250	250	250	250
Weight (kg)	5.0	6.5	10	15.5	17	35

• Jacket Type Dimensions and Weight

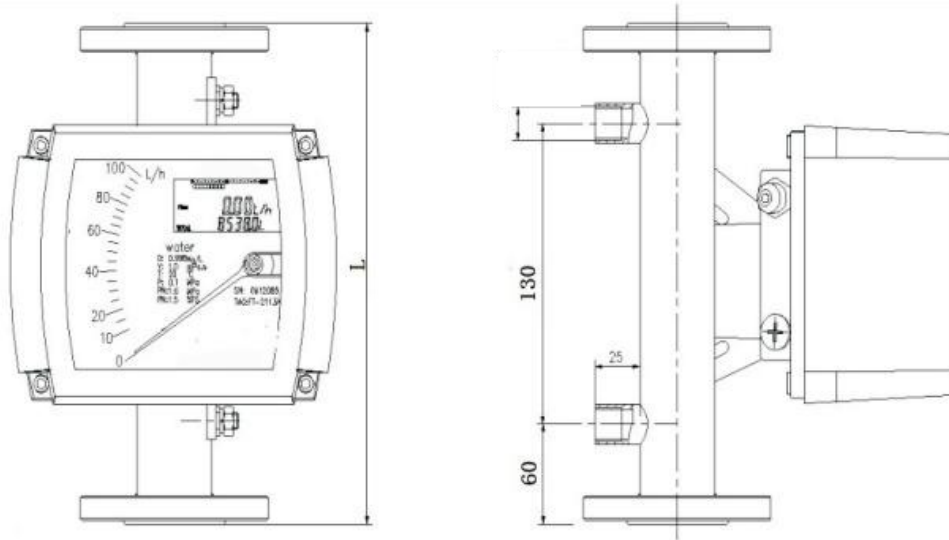

Insulation Jacket type

Caliber	DN15	DN25	DN50	DN80	DN100	DN150
L (mm)	250	250	250	250	250	250
Weight (kg)	7.5	10	13	19	21	38

• FEP Liner type Dimensions and weight

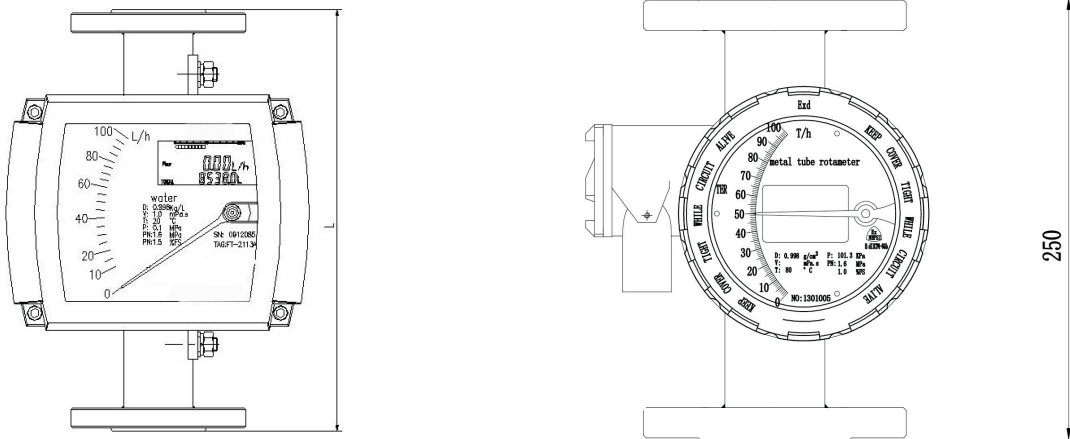

Square Convertor

Round Convertor

Caliber	DN15	DN25	DN50	DN80	DN100	DN150
L (mm)	250	250	250	250	250	250
Weight (kg)	5.0	6.5	10	15.5	16.5	32

• **FEP Liner type Dimensions and weight**

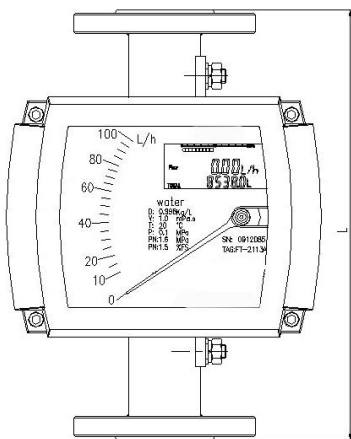

Square Convertor

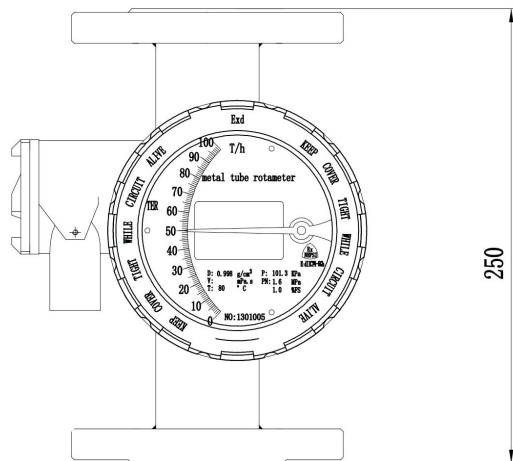

Round

Caliber	DN15	DN25	DN50	DN80	DN100	DN150
L (mm)	250	250	250	250	250	250
Weight (kg)	5.0	6.5	10	15.5	17	32

• **Side outlet type: Dimensions, weight and pressure loss**

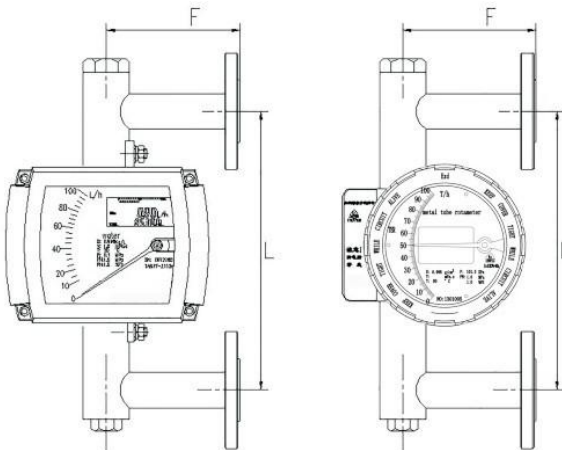

Caliber	DN15	DN25
F(mm)	120	120
L(mm)	250	250
Weight(kg)	6	7.2
Pressure loss(kpa)	21	30

(DN15~DN25)

• **Bottom inlet and side outlet type: Dimensions, weight and pressure loss**

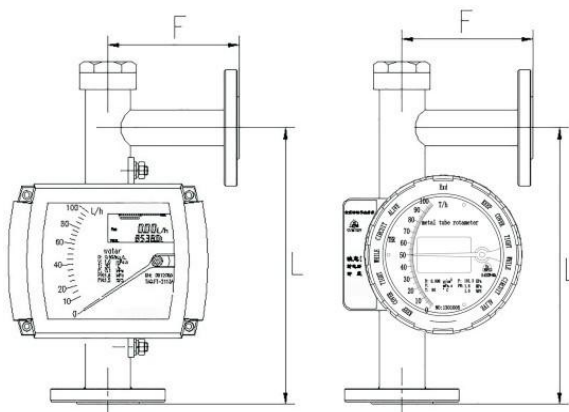

Caliber	DN15	DN25
F(mm)	120	120
L(mm)	250	250
H(mm)	6	7.2
Weight(kg)	6	7.2
Pressure loss(kpa)	21	30

(DN15~DN25)

• **Horizontal mounting type: Dimensions ,weight and pressure loss**

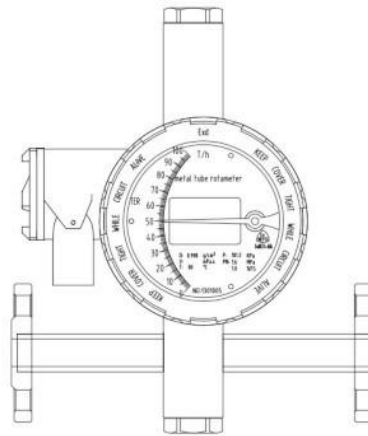

Caliber	15	20	25	40	50	65	80	100	125	150
L (mm)	250	250	250	300	300	400	400	400	500	500

(DN15~DN150 Gas)

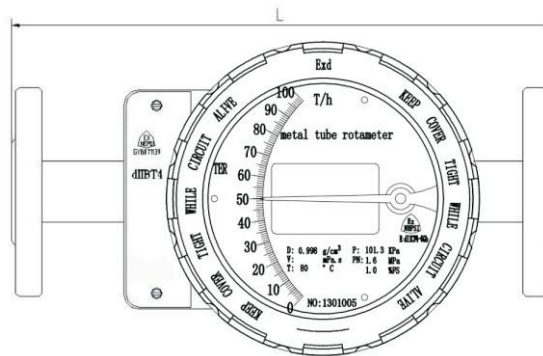

Caliber	15	20	25	40	50	65	80	100	125	150
L (mm)	250	250	250	250	250	250	250	250	250	250

(DN15~DN150 Liquid)

• **Additional structure and installation instructions**

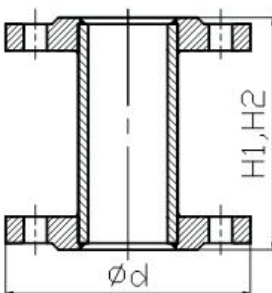

Straight pipe type

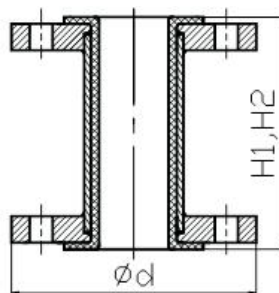

Liner FEP straight pipe type

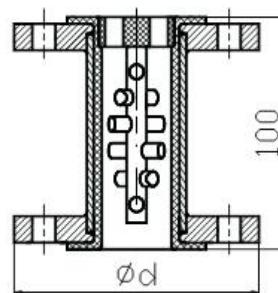

Liner FEP with Filter

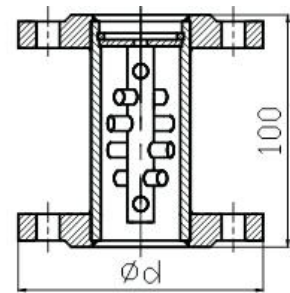

With Filter

Diameter	DN15	DN25	DN50	DN80	DN100	DN150
Front straight pipe H1 \geq (mm)	75	125	250	400	500	750
After straight pipe H2 \geq (mm)	250	250	250	250	250	250
ϕ d (mm)	95	115	165	200	220	285

2.5 Technical Parameters

Measuring range	16~150000 l/h water (20°C) 0.5~4000 m ³ /h gas (0.1013 MPa 20°C)
Turn down ration	10:1 (Special type 20:1)
Accuracy level	2.5 (Special type 1.5% or 1.0%)
Working pressure	DN15~DN50 1.6 MPa DN80~DN150 1.0 Mpa (Special type 1.6 MPa) Jacket pressure: 1.6 MPa
Medium temperature	Standard: -20°C ~+200°C High temperature: 300°C FEP liner type \leq 90°C
Ambient temperature	-20°C ~+100°C (remote type without LCD display \leq 85°C) (remote type with LCD display \leq 70°C)
Medium viscosity	Dn15: \leq 30 mPa.s DN25: \leq 250 mPa.s DN50~DN150: \leq 300 mPa.s
LCD display	Instantaneous flow numerical range: 0.000~99999 Total flow numerical range: 0.00~99999999
Signal output	Standard signal: Two-wires 4~20 mA (HART optional) Standard signal :Three-wires 0~10 mA
Communication	RS485, HART
Alarm signal	Two relay outputs (Limits 125VAC/0.25A) One or two proximity switches Pulse output:0~1KHz, Isolated output (Output Level Vpp)
Power supply	Standard: 24 VDC \pm 20% Customized: 220 VAC (85~265 VAC) Battery powered: 3.7@4.4~5.2 AH Lithium Battery, 3~12 months.
Connection	Flange (DIN, ANSI, JIS) Tri-clamp Thread (BSP, NPT)
Protection grade	IP65 / IP67

Ex-proof mark	Flame-proof : ExdIICT4~6Gb Intrinsically Safe Explosion Proof: ExialICT3-6
Sensor body	SS304
Float	SS304, SS316, Hastelloy, FEP

3. Intended Use

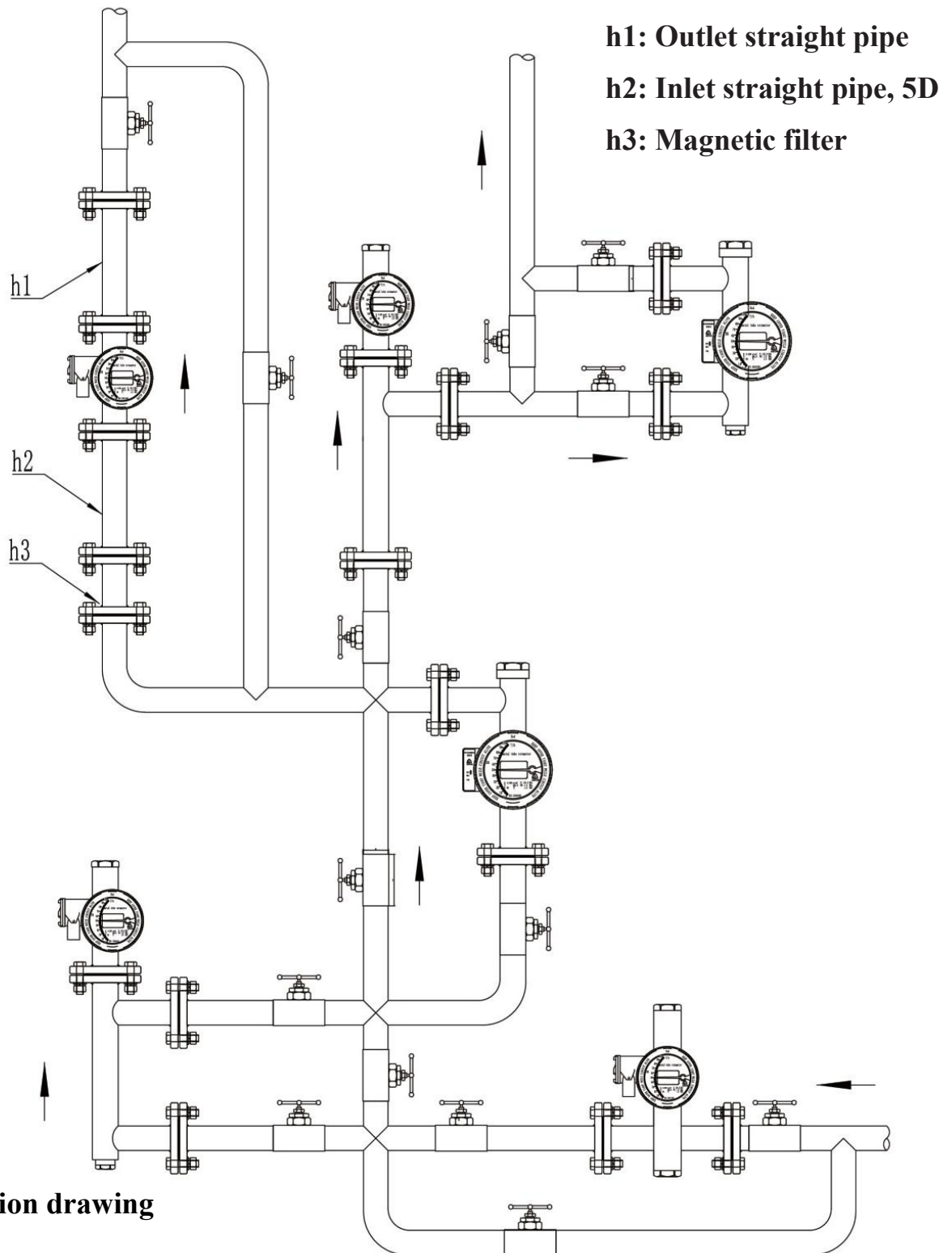



1. Remote type flow meter need to be earth grounded to get good electromagnetic compatibility.
2. Upstream section $\geq 5DN$ and downstream $\geq 250mm$ to eliminate the whirlpool effect.
3. The welding slag in the pipeline must be cleaned, and there mustn't be any magnetic particles in the magnetic coupling part.
4. When install anti-corrosion type flow meter, the strength should be moderately when fasten bolts of flanges to avoid damage to the sealing surface.
5. Please properly handle the waterproof problem of the cable connector to prevent rainwater from entering the case.
6. If there's magnetic particles in the medium, magnetic filter should be installed in the inlet. If there's non-magnetic particles, filter should be installed. If there is bubbles, exhaust should be installed.
7. Control valve should be installed in the downstream of flow meter. Working pressure should be more than pressure loss to make sure flow meter can work stably.
8. If medium is pulsating flow, a buffer device should be installed.
9. Open the control valve slowly to avoid damaging to the flow meter.
10. If pressure is unstable, especially for gas, a damping structure should be adopted.

4. Wiring

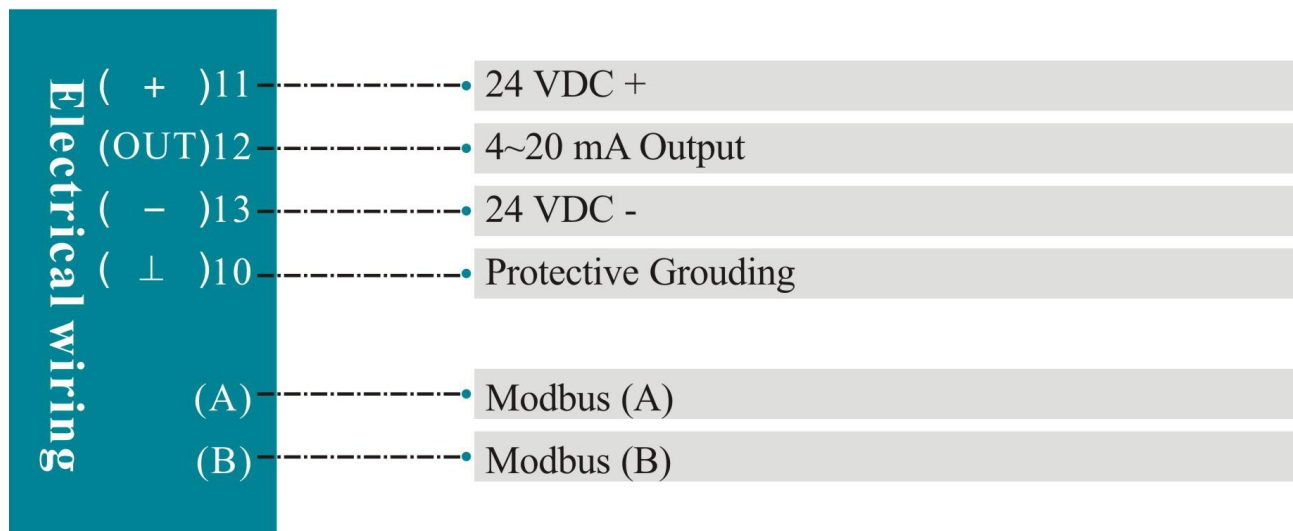
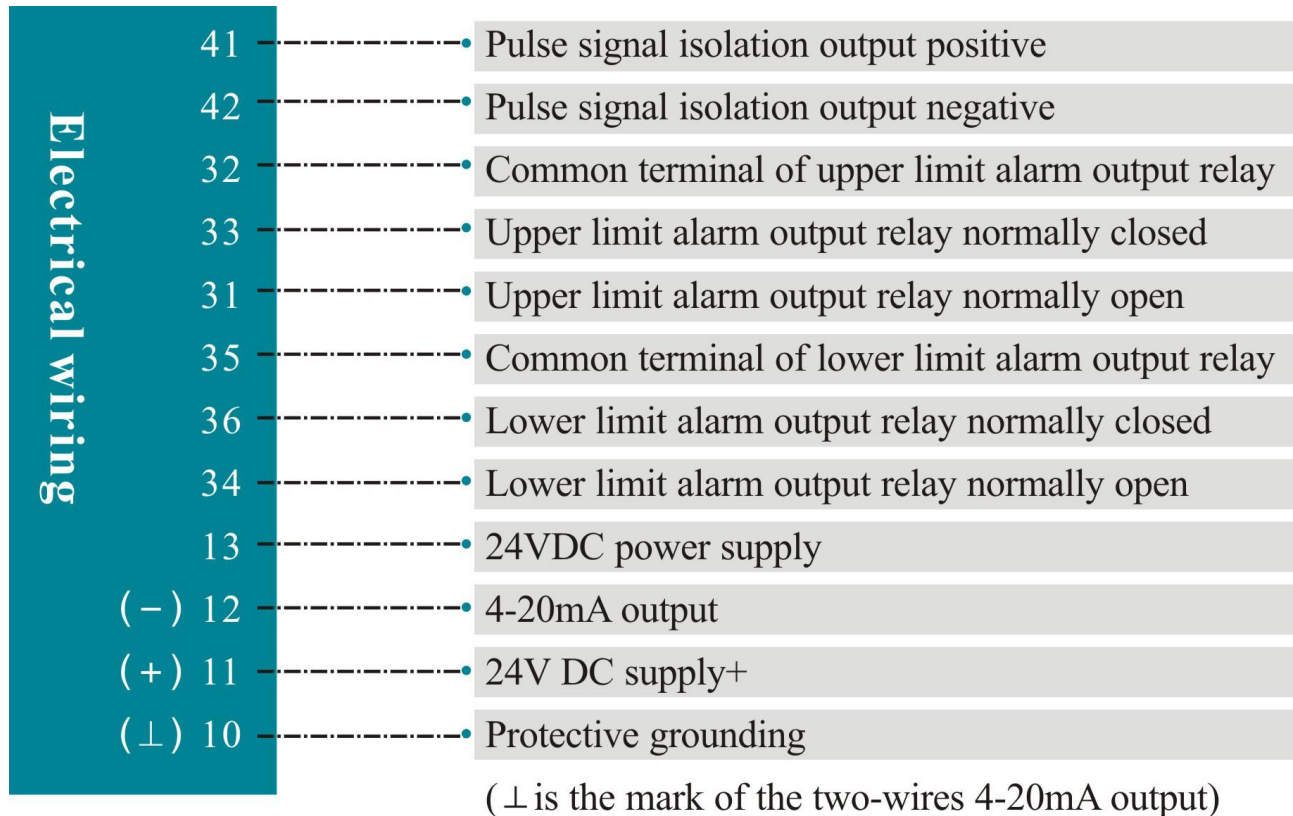

Note 1: When wiring in accordance with intrinsically safe explosion-proof requirements, please combine the wiring method of the relevant safety barrier.

Note 2: 24VDC power supply and pulse output are not in common ground!

Note 3: Battery powered model, use a specific power socket, no output.

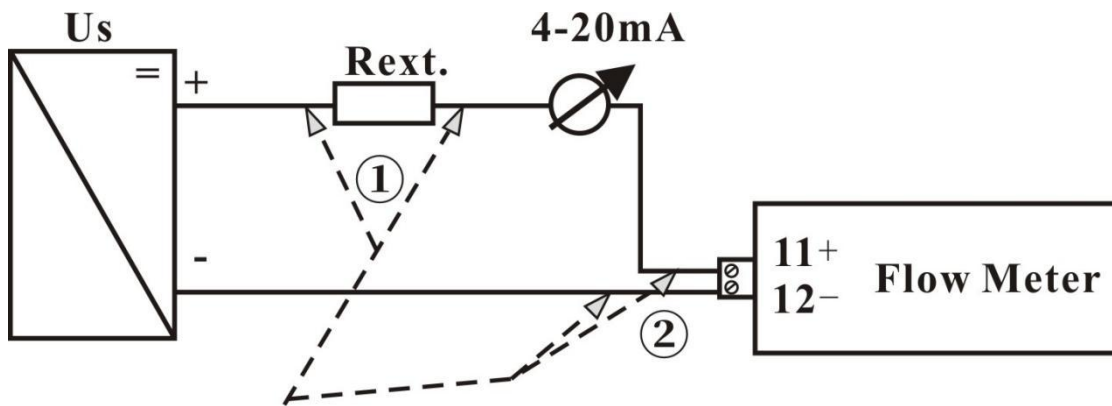

HART-communicator

Two-wires 4-20mA output connection (with HART)

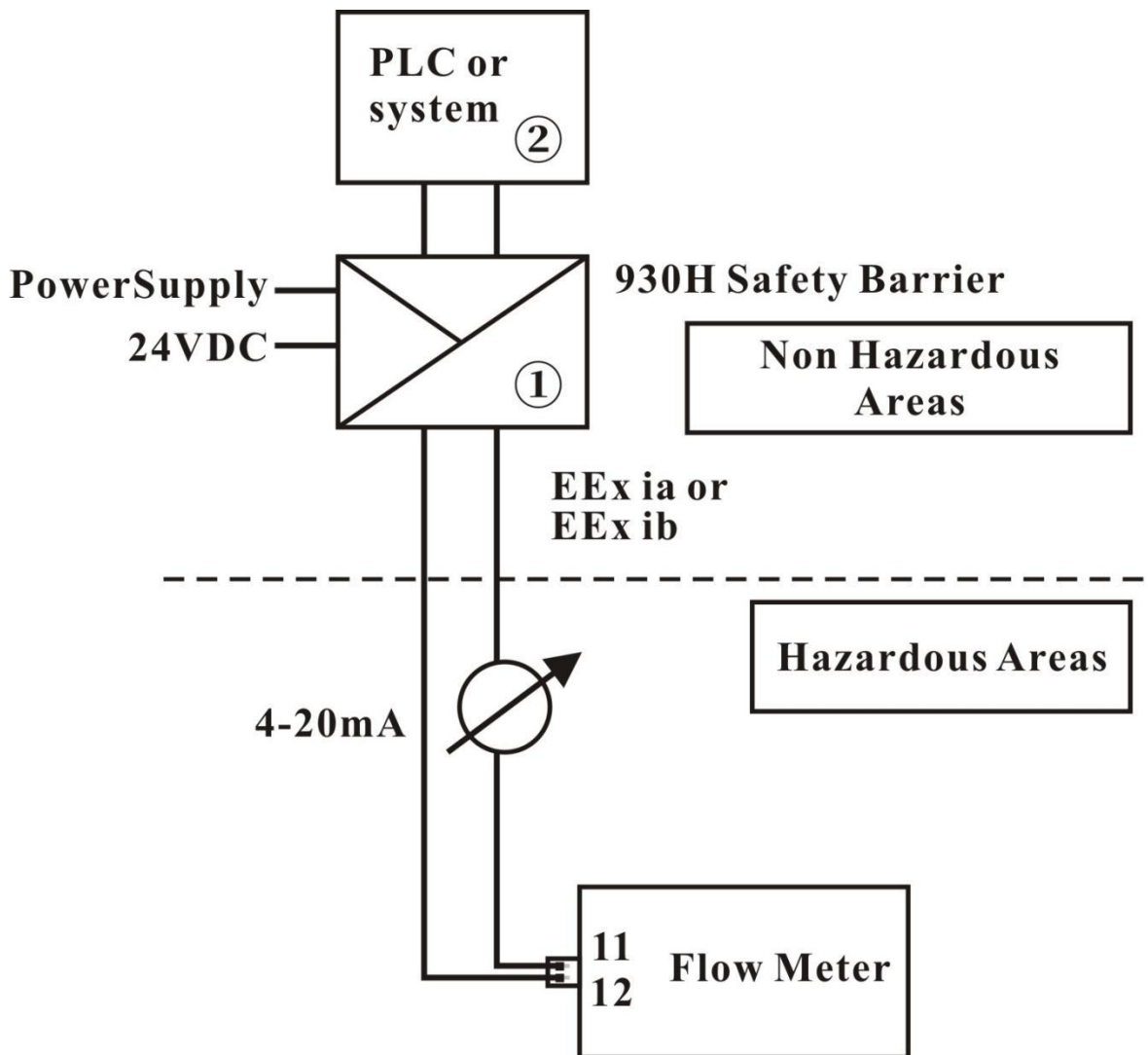

Intrinsic safety connection

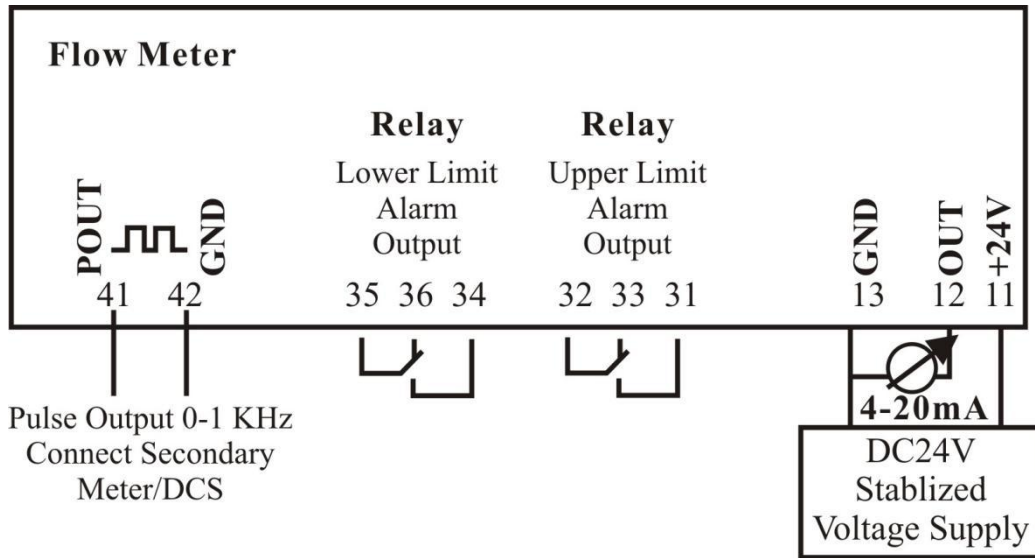

Relay output and pulse output connection

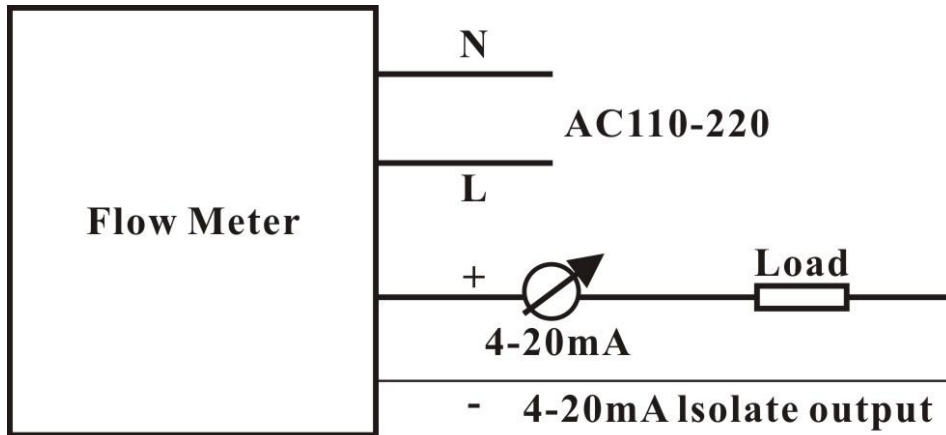

Note: Connect wire end and terminal “+”, “-” when don’t use 4~20 mA

AC power supply connection

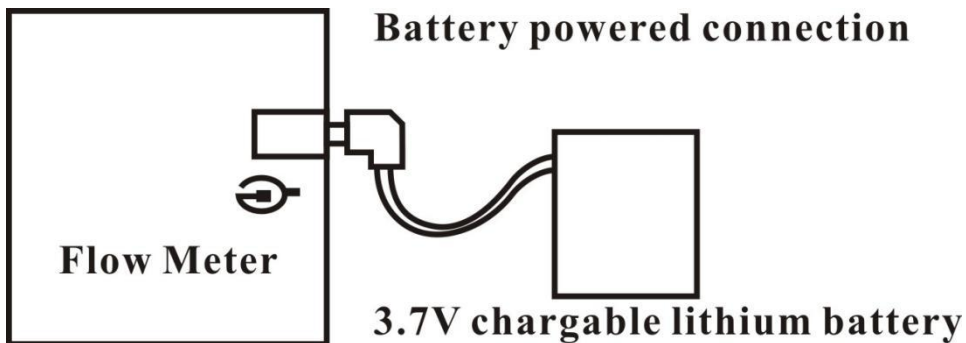

Battery powered connection



Hart

The HART375 handheld tool can be connected to the HART instrument in the remote control room or on-site for communication operations.

The handheld tool can be connected in parallel to the HART protocol device or to its load resistance (250Ω). Don't need to consider the polarity of the lead when connecting.

In order to ensure the normal communication of the handheld tool, there must be a minimum load resistance of 250Ω in the loop. The handheld tool does not directly measure the loop current.

After checking that the power supply of the meter loop is normal, press the key of the handheld tool for more than one second to turn on it. After the handheld starting, it will automatically search for the HART device with the polling address zero on the 4-20mA loop.

Features	HART shortcuts
Loop current test	2,2
Migration of 4/20mA	2,3,1
Zero trim	2,3,3,1
Station number	3,4
Date	3,5,1
Descriptor	3,5,3
Message	3,5,4
Final assembly code	3,5,5
PV Unit	4,2,1
PV URV	4,2,2
PV LRV	4,2,3
PV Damp	4,2,4

Note: The zero-trim function can correct instrument output zero deviation caused by the installation location and it generally can be conducted at the beginning of the HART devices and instruments periodic verification. The use of this feature requires the authorization of the HART instrument owner, or it may cause the error of the output of HART instrument.

5. Limit Switch

One or two limit switches can be installed in the pointer, when it reaches to the set value, the switch will send a alarm signal, the values have been set according to client's requests before delivery, values also can be set by client.

SC3.5-No limit switch is intrinsic safety explosion proof, it should be used together with transistor amplifier WE77/EX 1 or WE77/EX 2. SC3.5-NO limit switch is direct connection type, power supply is 24VDC, three wire output is 23.5V electric signal to the PLC

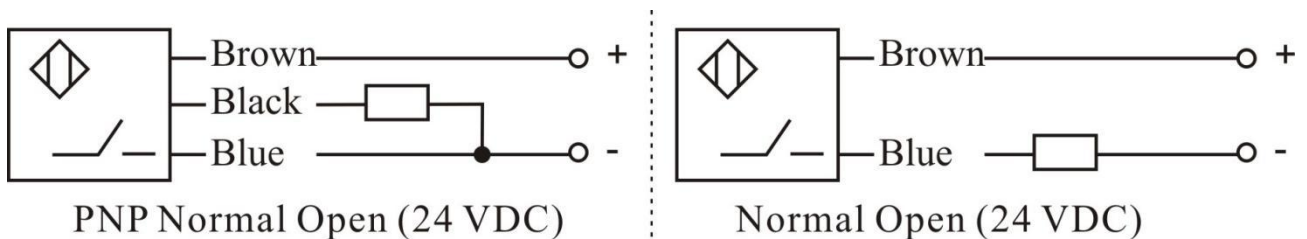
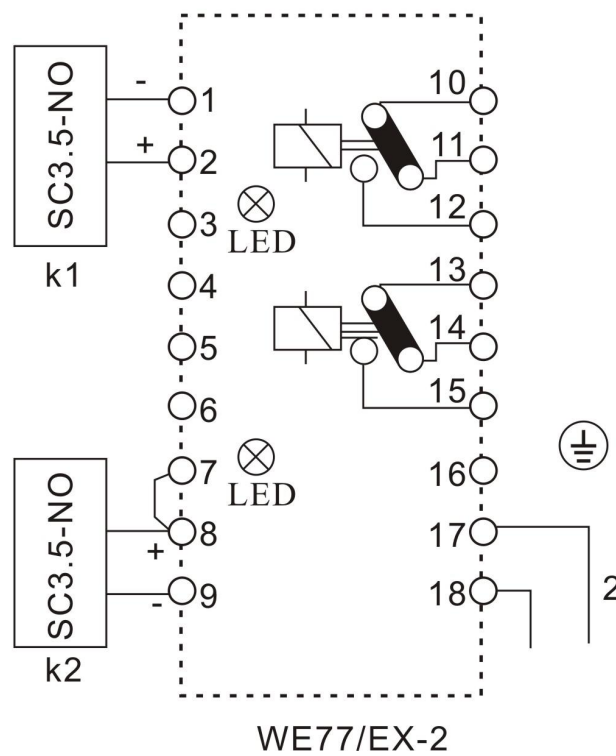
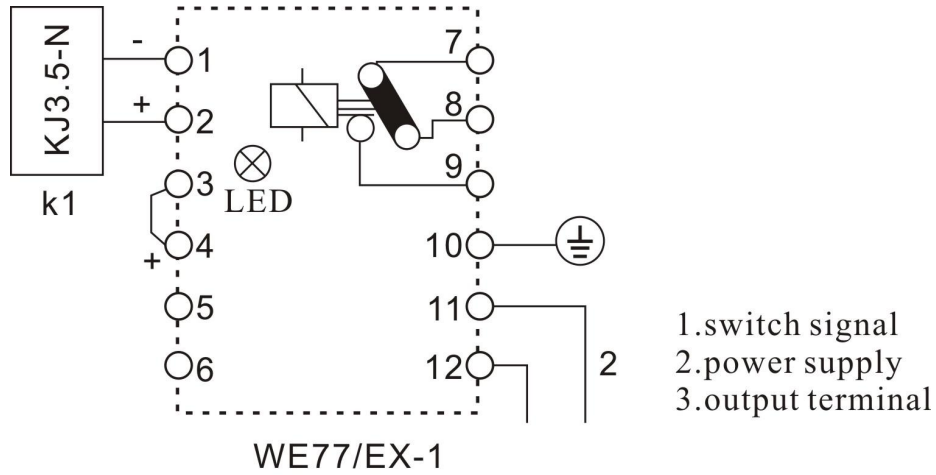

Three wire limit switch connection

Two wire limit switch connection

6. Flow Table

Flow Range Table

Diameter DN	Water (20°C) L/h		Air 0.1013MPa 20°C Nm ³ /h	Standard type Max pressure loss Kpa	
	1□	2□		water	air
15	16	-	0.5	2.0	7.0
	25	16	0.7	2.3	7.2
	40	25	1.1	2.5	7.3
	63	40	1.8	2.5	7.5
	100	63	2.8	2.5	7.8
	160	100	4.8	2.6	8.0
	250	160	7.0	2.7	10.0
	400	250	10.0	2.9	10.8
	600	400	16.0	3.4	14
20	600	400	16	4.0	7.0
	1000	600	30	4.1	8.0
	1600	1000	45	4.4	12.0
	2500	1600	70	5.2	19.0
	4000	2500	110	7.0	25.0
	6000	4000	180	12.5	33.0
25	600	400	16	4.0	7.0
	1000	600	30	4.1	8.0
	1600	1000	45	4.4	12.0
	2500	1600	70	5.2	19.0
	4000	2500	110	7.0	25.0
	6000	4000	180	12.5	33.0
32	1000	600	30	4.1	8.0
	1600	1000	45	4.4	12.0



	2500	1600	70	5.2	19.0
	4000	2500	110	7.0	25.0
	6000	4000	180	12.5	33.0
	10000		250	12.5	33.0
40	2500	1600	70	5.2	19.0
	4000	2500	110	7.0	25.0
	6000	4000	180	12.5	33.0
	10000		250	12.5	33.0
50	6000	4000	180	4.7	8.0
	10000	6000	250	5.1	15.0
	16000	10000	400	6.2	22.0
	25000	16000	600	8.0	35.0
65	16000	10000	400	6.2	22.0
	25000	16000	600	8.0	35.0
80	25000	16000	1000	5.3	15.0
	40000	25000	1200	7.8	22.0
	60000	40000	1600	8.3	25.0
100	60000	40000	1800	11.4	35.0
	100000	60000	3000	16.7	45.0
125	100000	40000	3000	11.4	42.0
	125000	50000	3000	11.4	47.0
150	150000	100000	4000	17.0	47.0

Notes: It's standard flow rate in this table.

Special specifications can be customized according to customer's inquiry.

7. Operation

SET UP Down Enter

7.1 Main Parameters

7.1 Main Parameters

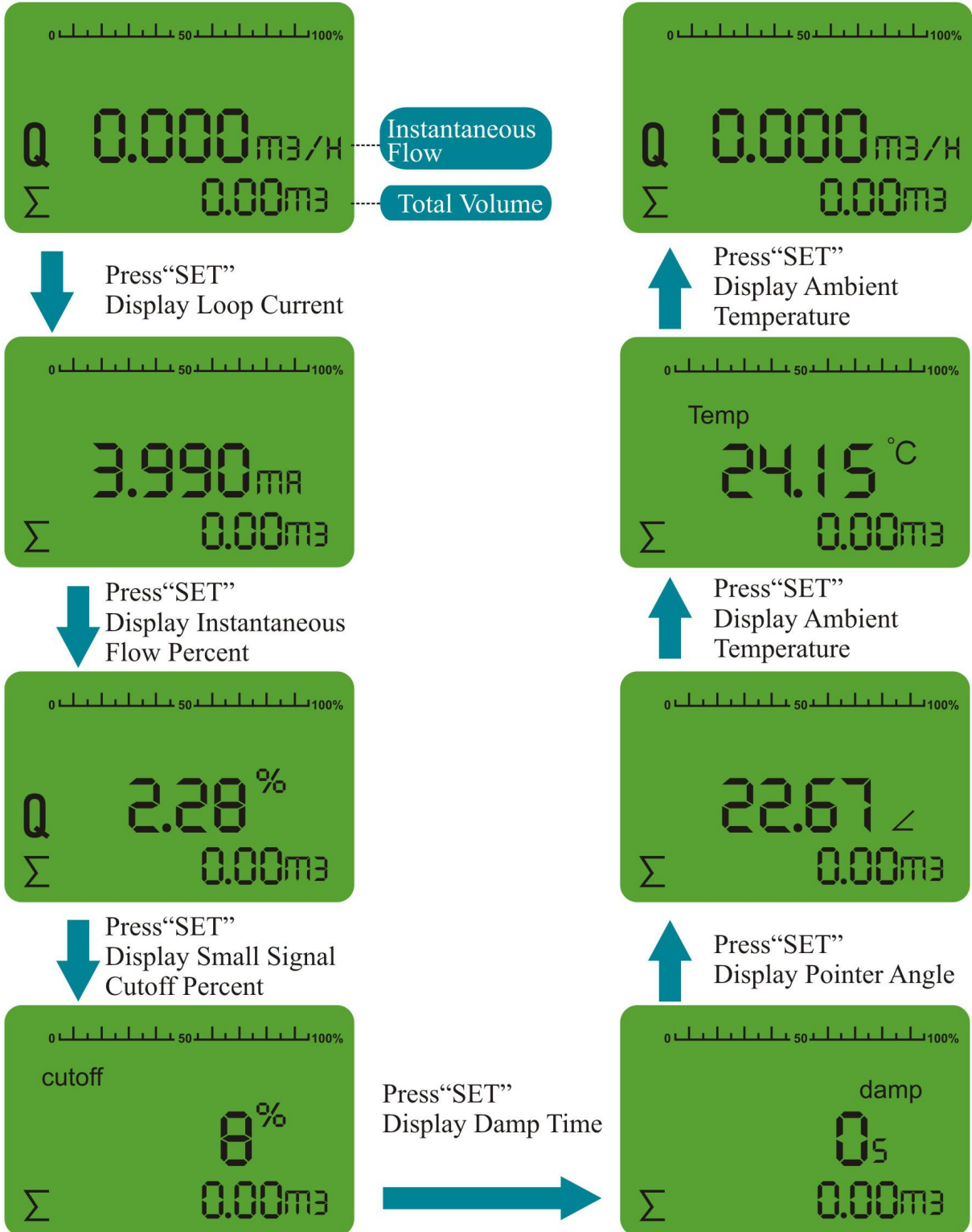

7.2 Clear Total Flow

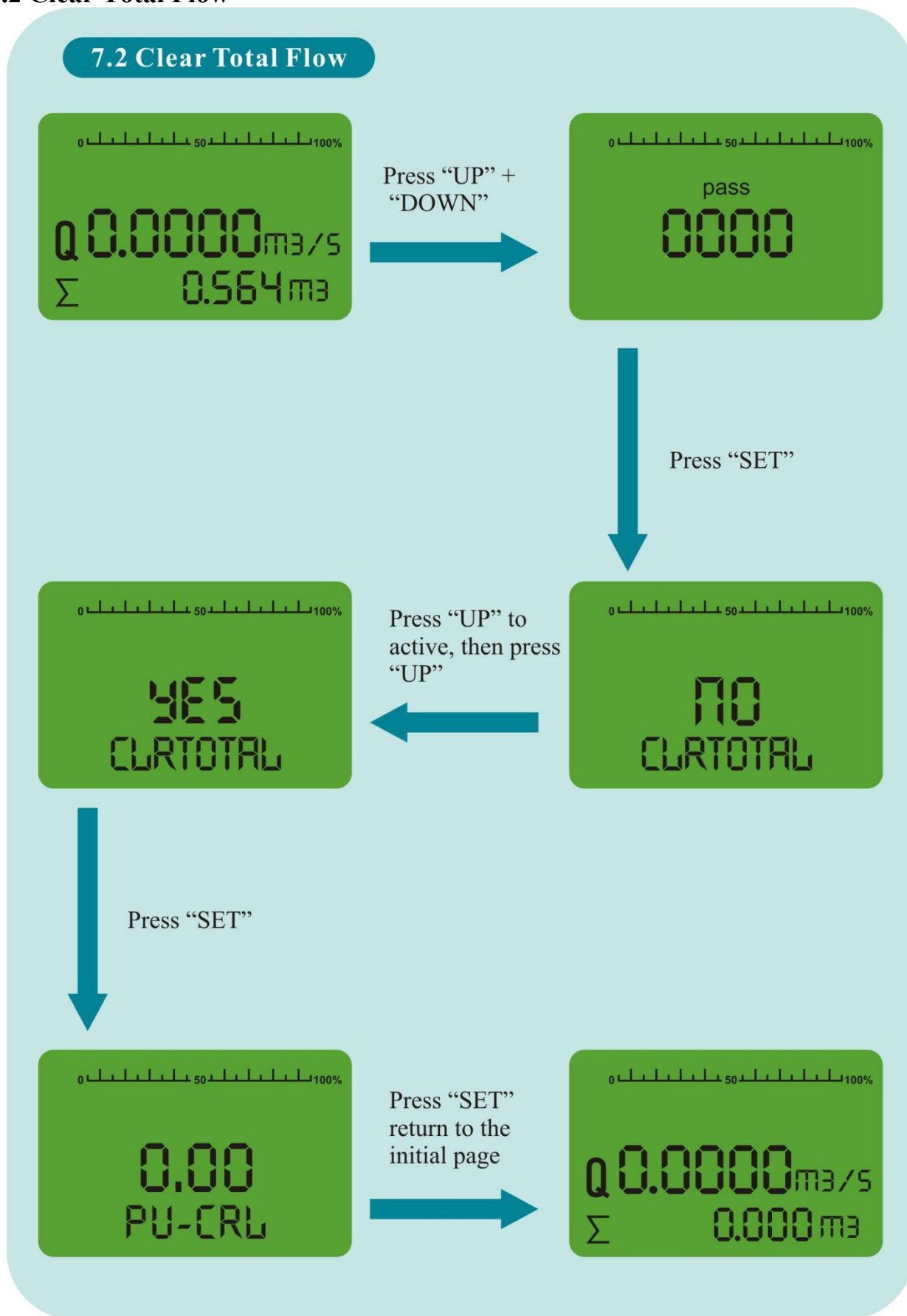

7.3 4 mA correction

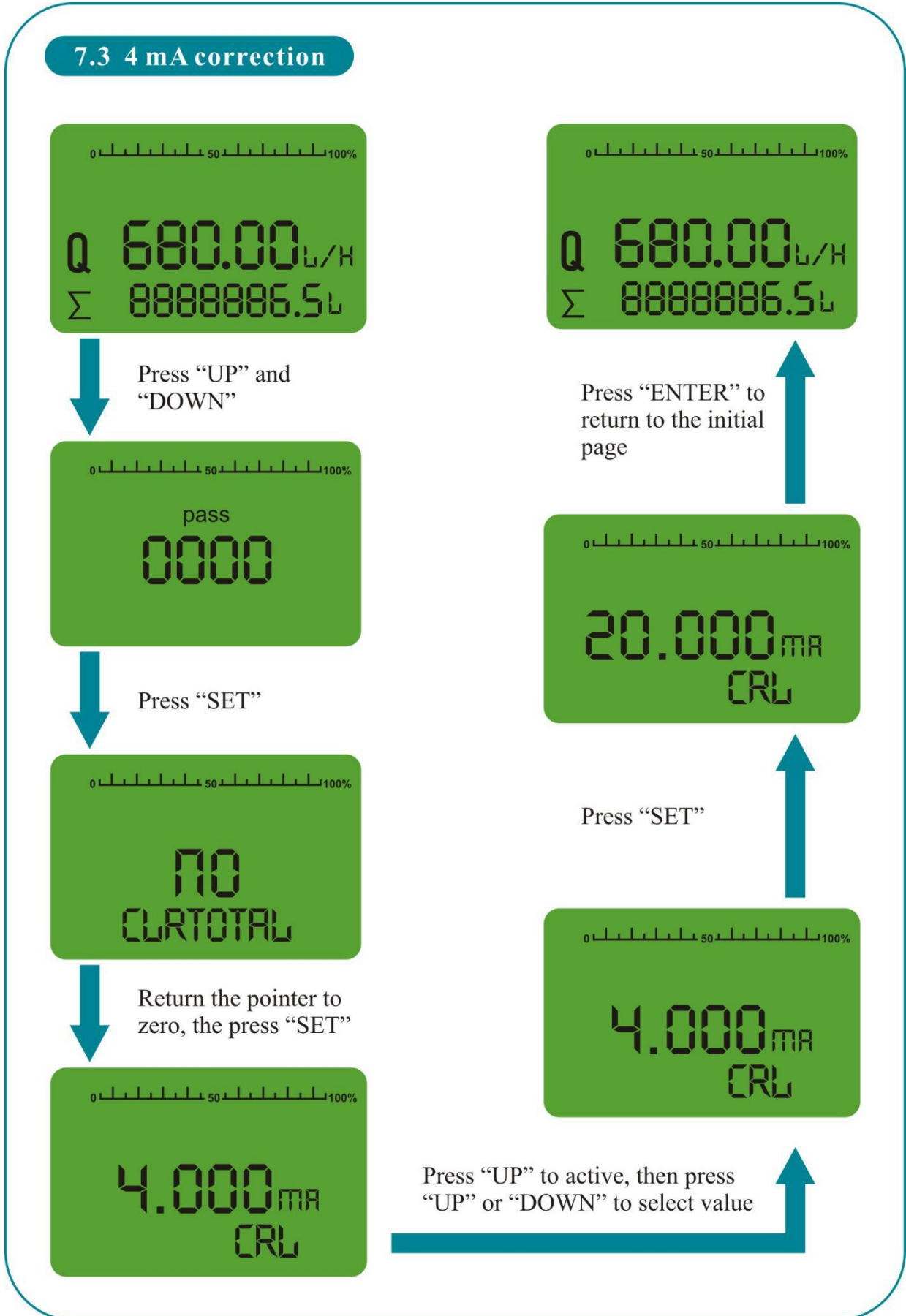

7.4 20 mA Correction

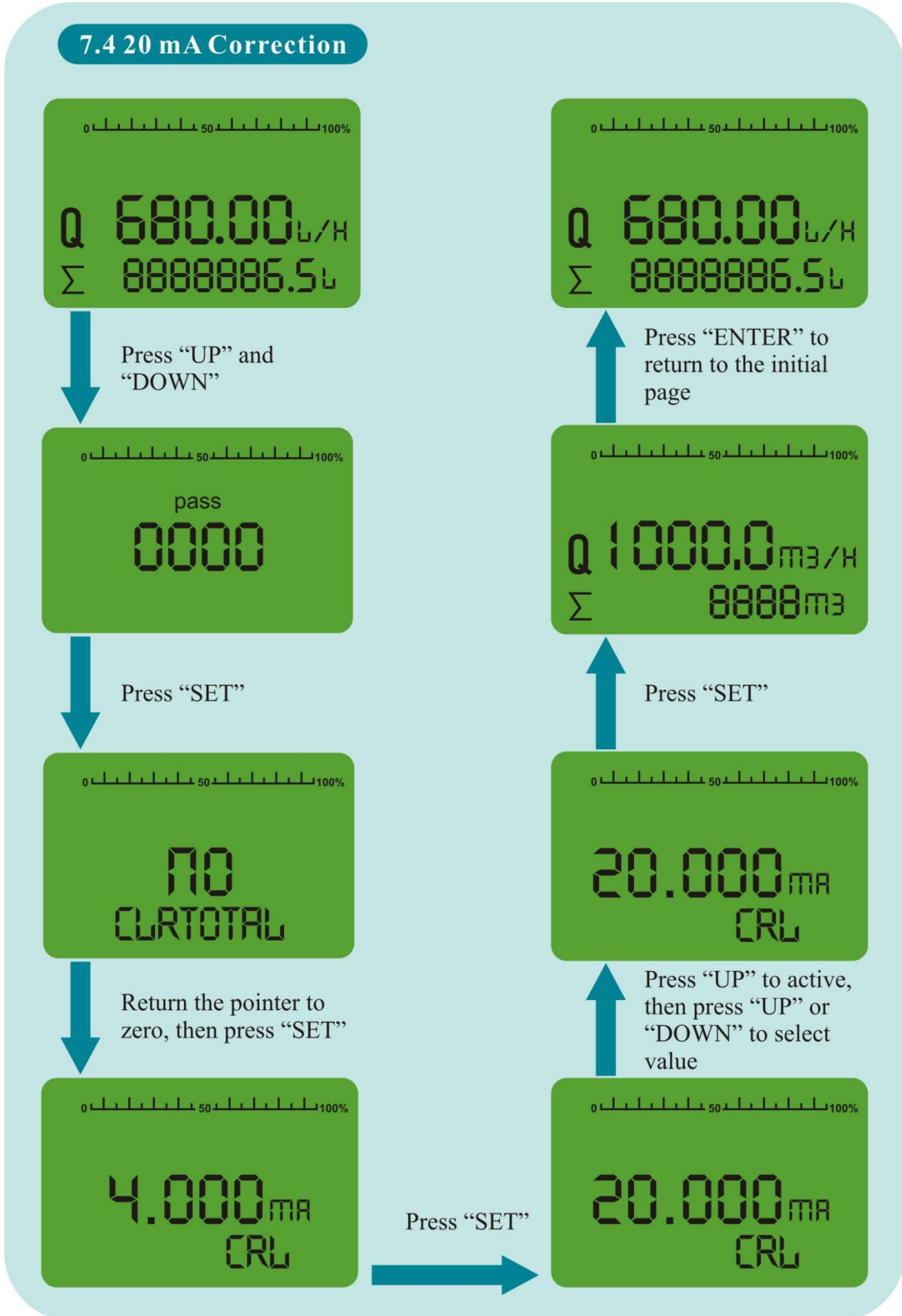

7.5 Flow Unit

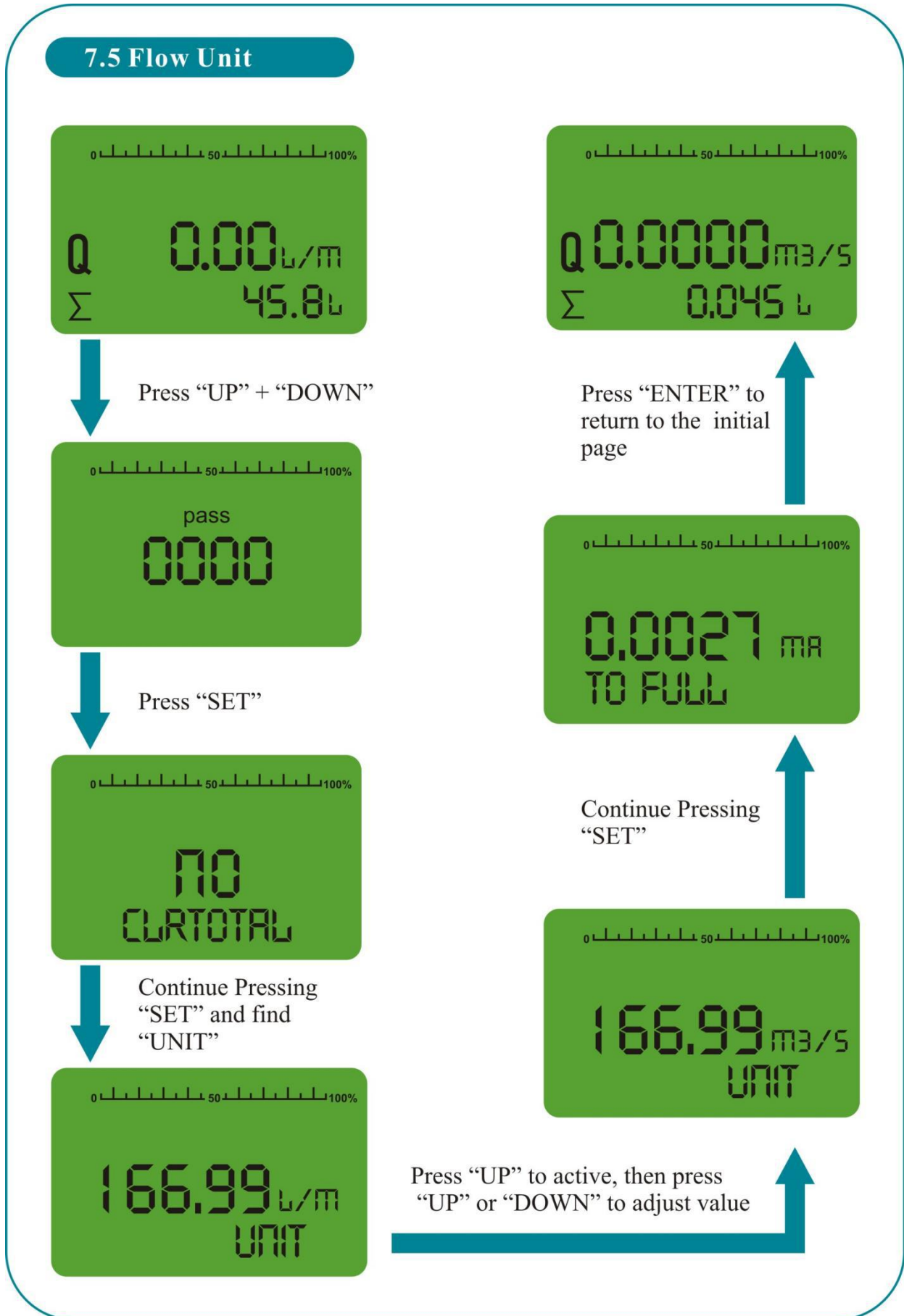

7.6 Damp

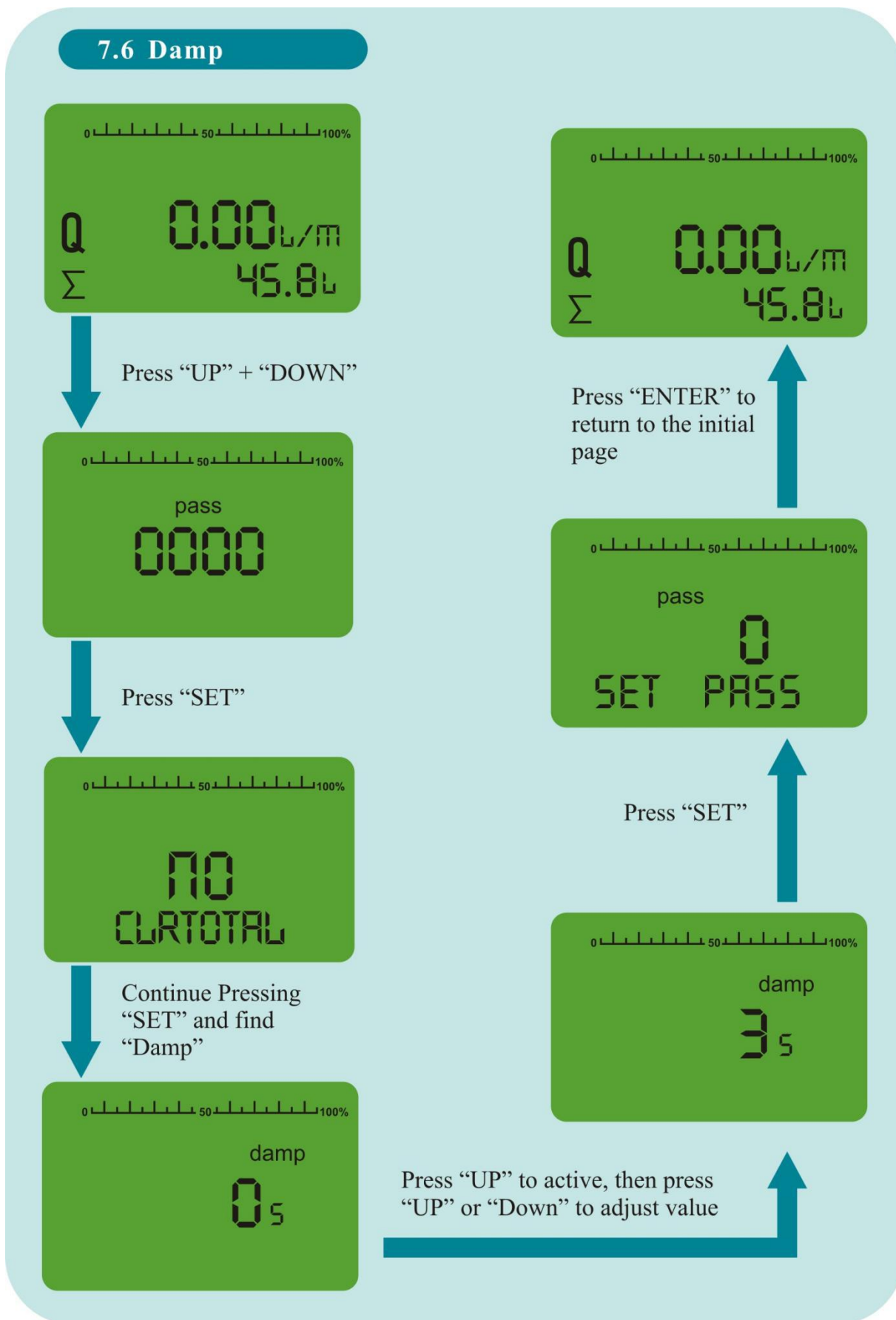

7.7 Small Signal Cutoff

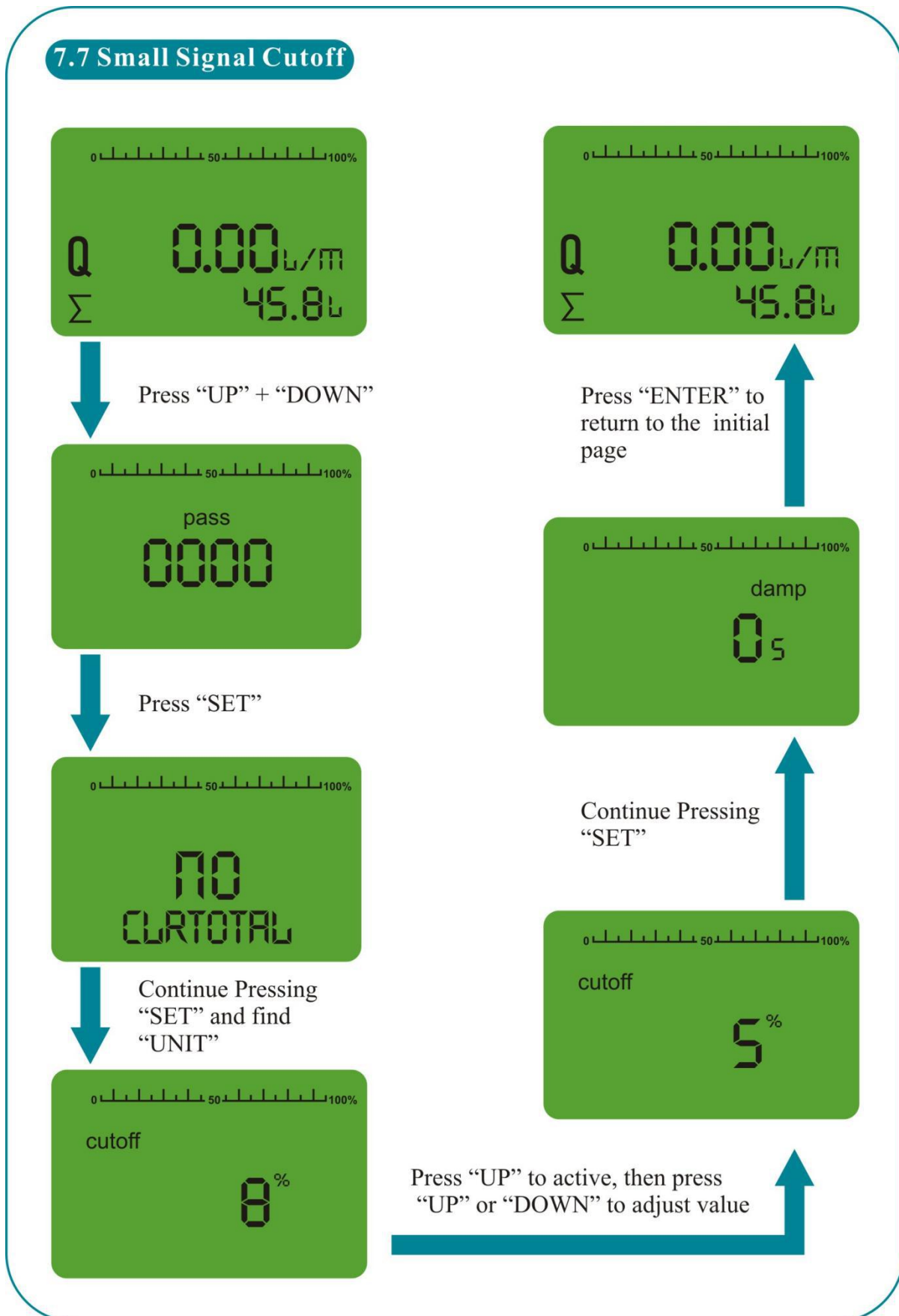

7.8 Measuring Range

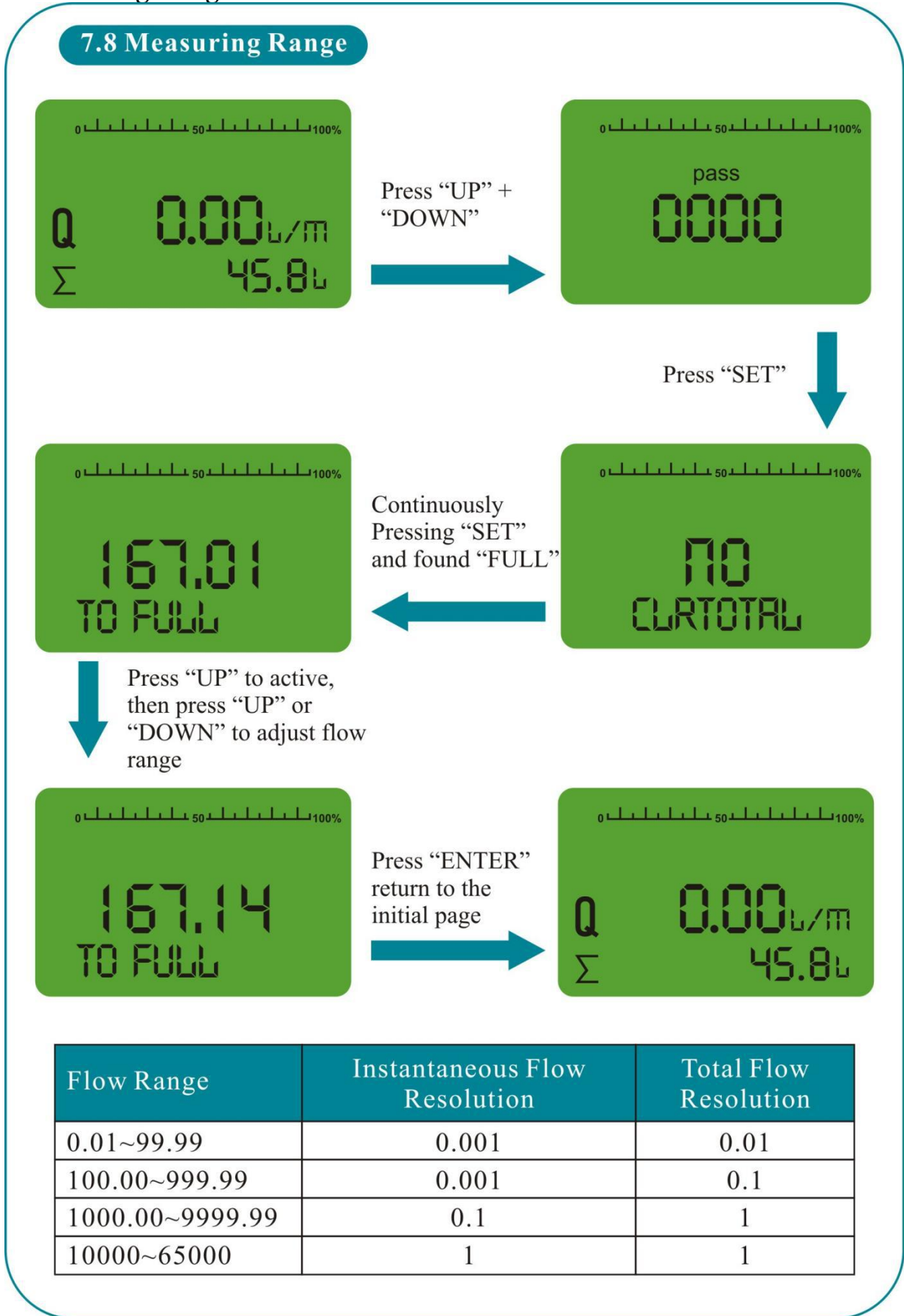

8. Trouble Shooting

Diagnosis	Possible Reason	Action
1.Pointer don't move after running	There're particles in the medium and the pointer is stuck Working pressure is too low	1.Clean up the particles, and install magnetic filters in front of the flowmeter 2.Increase working pressure
2.There's no analog output value	Wiring is loose Electricity board is broken	1.Check the wiring 2.Contact with manufacturer
3.The readings fluctuate seriously	1.Unstable working pressure 2.Pulsating flow or two-phase medium 3.Inlet and outlet bore change greatly which lead to increased pressure loss	Check the system and make sure stable working pressure Eliminate pulsating flow and two-phase medium 3.Reduce pressure loss
4.Pointer can't return to zero	Parts become deformed	Reshape parts
5.Large measurement error	1.Wrong installation 2.Bubbles in the medium	Installation according to user manual Install exhaust valve

Note: Above is some normal trouble shooting. If you have any more question, please contact with manufacturer.

SMERI s.r.l.

Via Mario Idiomi 3/13

I - 20057 Assago MI

Tel. +39 02 539 8941

E-mail: smeri@smeri.com - www.smeri.com