

## Overview

---

### Features

Continuous level measurement of solids and liquids applications with 78 GHz FMCW radar

#### Measurement range

- Up to 100 m (329 ft)

#### Mechanic

- Lens antenna and flange for quick and easy positioning
- Stainless steel housing
- Plane flanges and Easy aimer flanges

#### Service

- Plug and play system, simple installation and commissioning
- Configuration with only 6 parameters on display with push buttons
- Alternative configuration via HART possible.

#### Approvals

- Approval for use in Hazardous Locations (gas and dust)
- 2011/65/EU RoHS conform

---

## Application

### Solids measurement

Aiming is strongly suggested for solid measurement. It helps to optimize the echo signal (mainly for low material level in the cone) and helps to solve not perfect mounting positions.

For proper mounting positions vertical installation without aiming is possible.

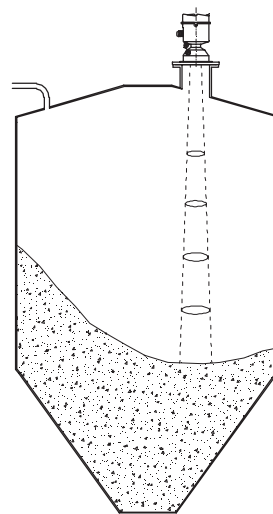
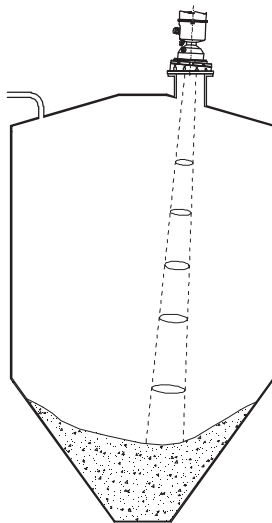

## Specification

<b>Process</b>	Measurement range	40 m (131 ft) or 100 m (328 ft)
	Min. detectable distance	400 mm (15.7") from sensor reference point
	Process temperature	-40 .. +100°C (-40 .. 121°F) or -40 .. +200°C (-40 .. 392°F)
	Process overpressure	-1 .. +0.5 bar (-14.5 .. +43 psi) or -1 .. +3.0 bar (-14.5 .. +43 psi)
<b>Performance</b>	Frequency	78 .. 79 GHz FMCW
	Beam angle	4°
	Accuracy of measurement	5 mm (0.2")
	Update time	Maximum 10 seconds (Response Rate (2.4.1.) set to FAST)
	Dielectric constant of material measured	For ranges up to 20 m (65.6 ft): min. DK = 1.6 For ranges up to 100 m (328 ft): min. DK = 2.5
<b>Mechanics</b>	Ingress protection	Type 4X/ NEMA 4X, Type 6/ NEMA 6, IP68
	Enclosure	316L/ 1.4404 Lid with window (window material polycarbonate)
	Lens antenna	Material: 40 m version: PEI 100 m version: PEEK
	Air Purge Connection	Female 1/8" NPT fitting Non return valve for 6 mm tube (optional)
<b>Electronics</b>	Power supply/ Communication	4-20 mA loop power Nominal 24V DC (16.5 .. 30 V DC) Protocol HART, Version 6.0
	Plug on display (inside housing)	Removeable graphic LCD, with bar graph representing level
<b>Approvals</b>	<b>CE/ UKCA</b>	
	<b>ATEX/ UKEX/ IEC-Ex</b>	
	Zone 20 and Zone 20/21	Dust ignition proof
	Zone 2	Increased Safety/ Intrinsically Safe
	<b>FM/ CSA</b>	
	General purpose	
	Cl. II, III Div.1	Dust ignition proof
	Cl. I Div.2	Non-incendive
	<b>TR-CU</b>	
	Ordinary Location	
	Zone 20 and Zone 20/21	Dust ignition proof
	Zone 2	Non-sparking
	<b>Radio</b>	
	RED (Europe) FCC Conformity (US) Industry Canada	

## NR 3100

Version with Easy Aimer flange  
Fig. states Easy Aimer flange 100 mm/ 4"



Version with plane flange  
Fig. states plane flange 100 mm/ 4"



Plug on Display  
With push buttons.

For programming of the unit.  
Once programmed, the Plug on Display can be removed if desired and used to copy parameters to multiple units.



## Dimensions

### Plane flange version

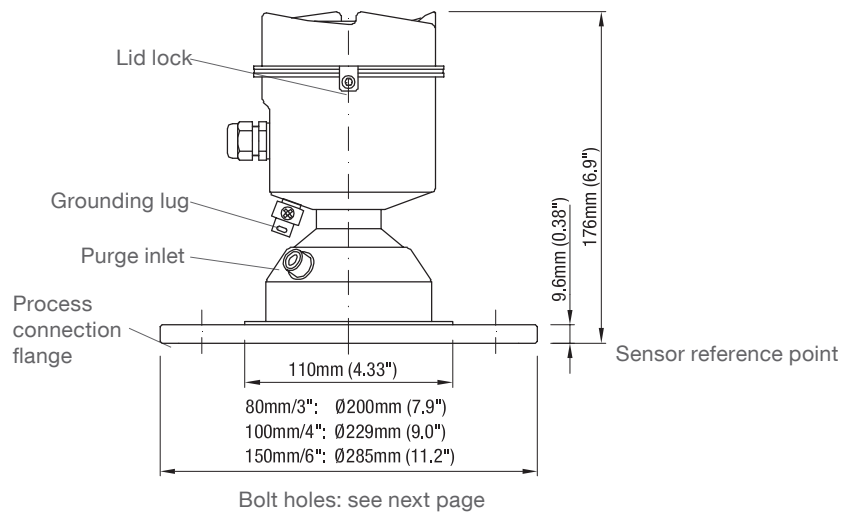

### Easy Aimer flange version 80 mm/ 3"

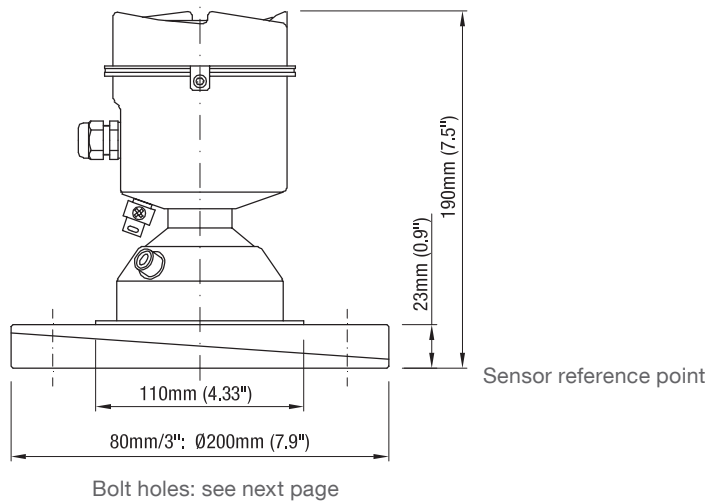

### Easy Aimer flange version 100 mm/ 4" 150 mm/ 6"

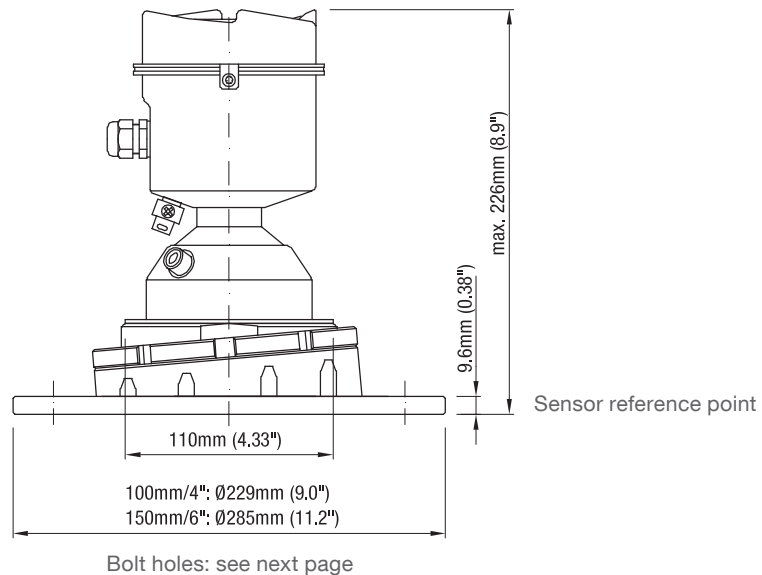

## Dimensions

### Flanges

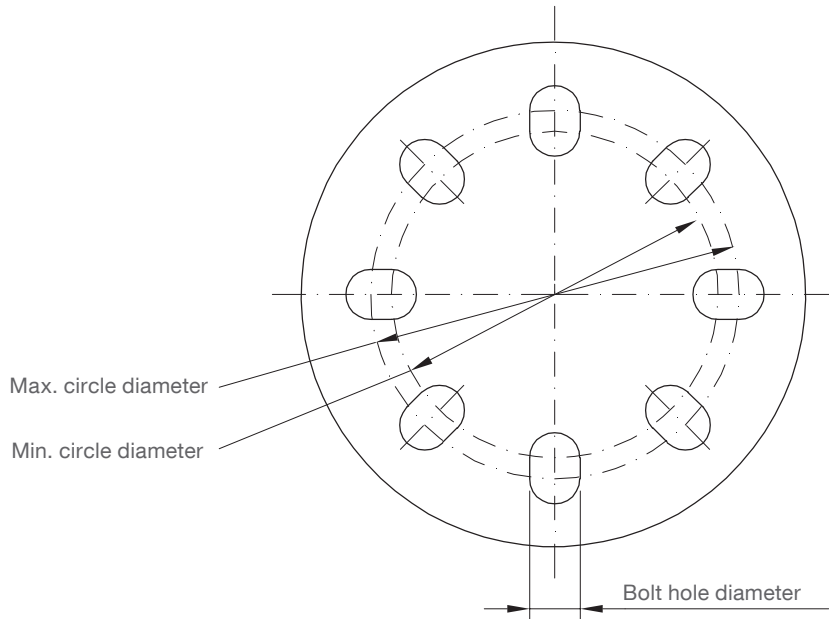

Universal flange (plane flange and Easy aimer flange) mates with bolt hole pattern of:  
 EN 1092-1 (PN16)  
 ASME B16.5 (150 lb)  
 JIS 2220 (10K)

Pipe size	Max. circle diameter	Min. circle diameter	Bolt hole diameter	Number of bolt holes
80 mm/ 3"	160 mm (6.30")	150 mm (5.91")	19.3 mm (0.76")	8
100 mm/ 4"	191 mm (7.52")	175 mm (6.89")	19.3 mm (0.76")	8
150 mm/ 6"	242 mm (9.53")	240 mm (9.45")	23 mm (0.90")	8

## Detailed Ex-markings

Pos.2

### Zertifikat

0	CE/ UKCA/ TR-CU FM/ CSA	General purpose
F	ATEX/ UKEX IEC-Ex ATEX/ UKEX IEC-Ex FM/ CSA FM/ CSA TR-CU TR-CU	II 1D, 1/2D, 2D Ex ta IIIC T139°C Da IP68 Ex ta IIIC T139°C Da IP68 II 3G Ex ec IIC T4 Gc, Ex ic IIC T4 Gc Ex ec IIC T4 Gc, Ex ic IIC T4 Gc DIP Class II, Div.1, Gr. E, F, G, Class III NI Class I, Div.2, Gr. A,B,C,D 2Ex nA IIC T4 Gc X Ex ta IIIC T139°C Da X

## Electrical installation

### 4-20 mA

The terminals are located below the display. To connect the unit, remove the display by gently turning the display a quarter turn counter-clockwise until it is free.

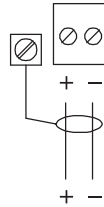

Use twisted pair cable: 0.34 mm<sup>2</sup> to 2.5 mm<sup>2</sup> (AWG 22 to 14)  
 Connect cable shield to ground terminal

24 V DC/ 4-20 mA loop

Additional ratings relevant for Ex-versions in Ex ec und Ex ic:

Increased Safety (Ex ec):  $U_n = 32 \text{ V}$

Intrinsically Safe (Ex ic):  $U_i = 32 \text{ V}$ ,  $I_i = 22.63 \text{ mA}$ ,  $C_i \leq 5 \text{ nF}$ ,  $L_i \leq 20 \mu\text{H}$

### 4-20 mA HART

Typical PLC/mA configuration with HART:

- Depending on the system design, the power supply may be separate from the PLC, or integral to it.
- HART resistance (total loop resistance, that is, cable resistance plus 250 Ohm (external resistor) must be less than 550 Ohm @24V supply for the device to function properly.
- The external resistor is not required, if the PLC has an integral 250 Ohm resistor.

