

Overview

- Level limit detection in bulk goods/ solids
- Compact unit
- Wide range of applications
- No maintenance
- Full, demand, empty detector
- Aluminium or plastics housing
- RF technology
- Active shield technology
- Self diagnostics
- Auto calibration
- ATEX, UKEX IEC-Ex, FM, FMc, TR-CU, KC, CCC Gas Ex and Dust Ex approvals
- FDA and 1935/2004/EC Food grade materials

Approvals	CE/ UKCA/ TR-CU	
	ATEX/ UKEX/ IEC-Ex/ TR-CU	
	Zone 20/21	Dust Ignition Proof
	Zone 1	Flameproof/ Increased Safety
	KG/ CCC	
	Zone 20/21	Dust Ignition Proof
	Zone 1	Flameproof
	FM/ FMc	
	General purp.	
	FM	
	Cl. II, III Div. 1	Dust Ignition Proof
	Cl. I Div. 1 Cl. I Zone 1	Explosionproof

Electronics	Supply voltage/ Signal output	21 .. 230 V AC/ DC ±10% Relais DPDT
	Technology	RF with active shield
	Signal output delay	0.5 .. 60 sec
	Measuring range/ max.s ensitivity	3 .. 100 pF/ 0.5 pF 3 .. 400 pF/ 2 pF
	Preset sensitvty	2 pF default, other sensitivity optional
	Calibration	Auto power up calibration at first time operation Auto recalibration with uncovered probe Push button calibration Manual calibration
	Display	4 digit LCD Display of actual measured capacitance, signal output state and self diagnostics
	Self diagnostics	Auto or manual function test Over and Under Range Actual calibrated switchpoint capacitance Min. and max. electronics temperature

Housing		
Standard Aluminium	d (flameproof) Aluminium	de (flameproof/ increased safety) Aluminium
		

Cable entries (by default)

Depending on model selected, the following cable entries are supported (options see pos.33):

Version:	Cable entries:
Flameproof (pos.2 T,D,L,5)	M20 x 1.5 (1x open conduit + 1x blind plug)
FM/FMc (pos.2 M,N,U)	NPT ½" tapered ANSI B1.20.1 (1x open conduit + 1x blind plug)
All other versions	M20 x 1.5 (1x screwed cable gland + 1x blind plug)

Applications

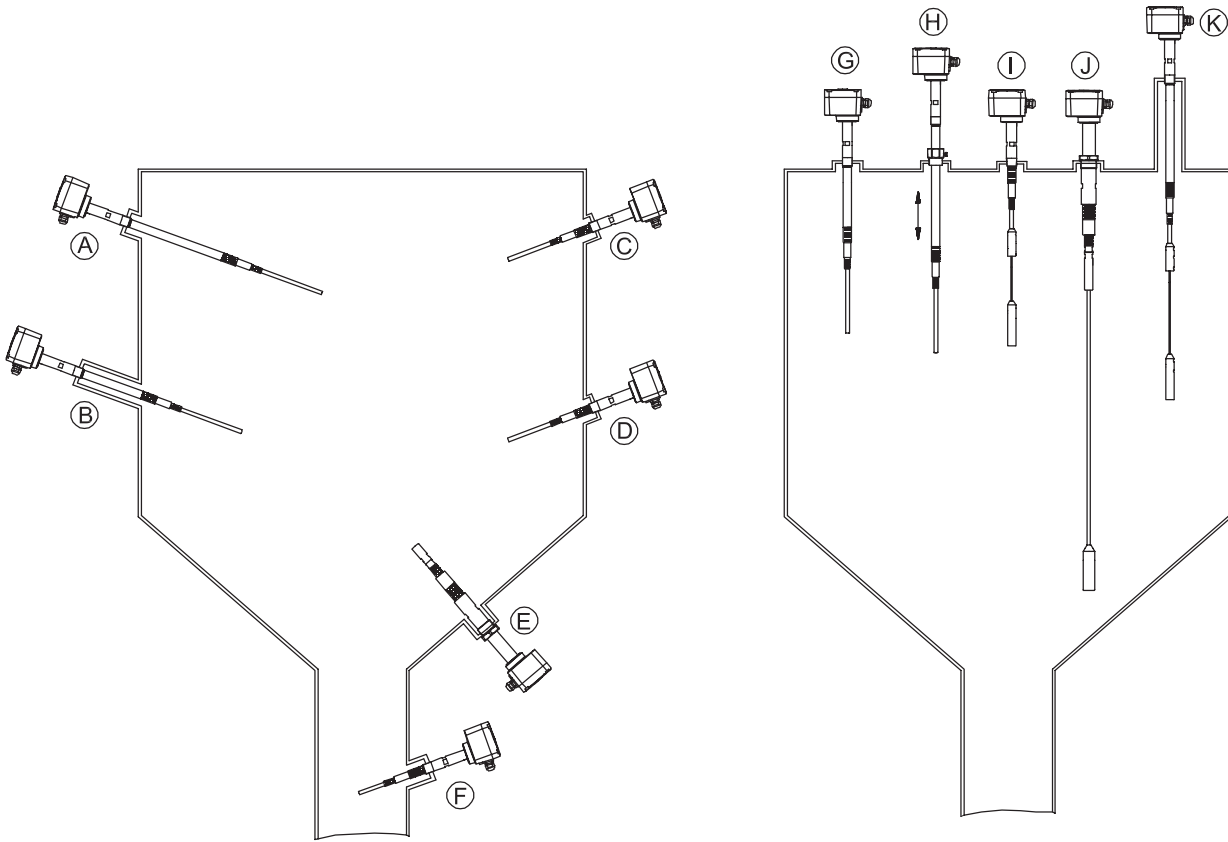

		RF 3100	RF 3200	RF 3300
(A)	Inactive length to reach distance from silo wall	•	•	•
(B)	Inactive length due to long mounting nozzle	•	•	•
(C)	Full detector with short length	•	•	•
(D)	Demand detector with short length, observe max. load	•	•	•
(E)	Empty detector with short length, observe max. load	•	•	•
(F)	Application in down pipe, observe max. load	•	•	•
(G)	Inactive length to bring active probe to required level	•	•	•
(H)	Inactive length and sliding sleeve for adjustable height	•	•	
(I)	Full detector, rope version	•	•	•
(J)	Empty detector, rope version, observe max. load	•	•	•
(K)	Inactive length due to long mounting nozzle	•	•	•

RF 3100 Standard version

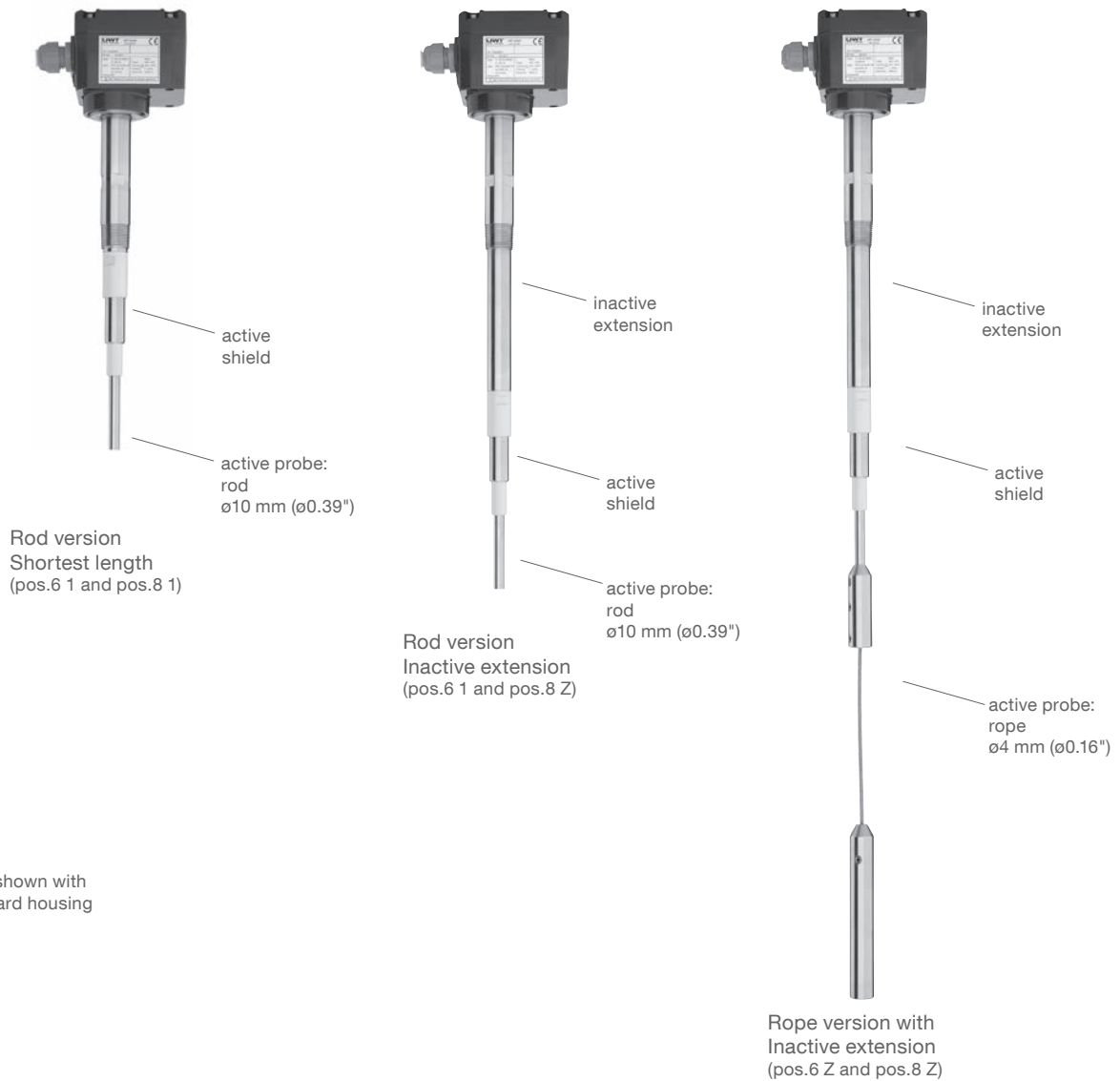

Units shown with
Standard housing



RF 3100 Standard version

Total length L	200 .. 2,500 mm (7.9 .. 98.4") rod 450 .. 20,000 mm (17.7 .. 787") rope
Active rod/ rope diameter	Rod \varnothing 10 mm (\varnothing 0.39") Rope \varnothing 4 mm (\varnothing 0.16")
Ambient temperature	-40 .. +70°C (-40 .. 158°F) Ex flameproof/XP +60°C (140°F)
Process temperature	-40 .. +240°C (-40 .. +464°F)
Process pressure	-1 .. +25 bar (-14.5 .. +363 psi)
Lateral load (rod version)	max. 20 Nm (\varnothing 10 mm probe), max. 125 Nm (\varnothing 22 mm pipe)
Tensile load (rope version)	max. 4 kN
Process connection material/ Extension material	1.4301/ 1.4305/ 1.4541 (SS303/ 304/ 321) or 1.4404/ 1.4401 (SS316L/ 316)
Probe isolation material	PPS reinforced FDA and 1935/2004/EC conform
Probe gasket material	FKM

Length L1

Rod version,
horizontal mounting

DK*	L1 (pos.6)/ mm (inch)
<1.5	n.a.
\geq 1.6	\geq 300 (11.8")
\geq 1.8	\geq 200 (7.9")
\geq 2.2	\geq 100 (3.9")
\geq 10	\geq 50 (2.0")

*see external
DK table

With stated L1 the
unit works with
factory setted
sensitivity (2 pF).
For shorter L1 see
option pos.16

Switchpoint

Rope version

x mm (inch)
n.a.
\leq 300 (11.8")
\leq 200 (7.9")
\leq 100 (3.9")
\leq 50 (2.0")

The table states
the switchpoint
with factory
setted sensitivity
(2 pF). For smaller
x see option
pos.16

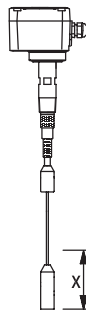

RF 3200 Heavy Duty version

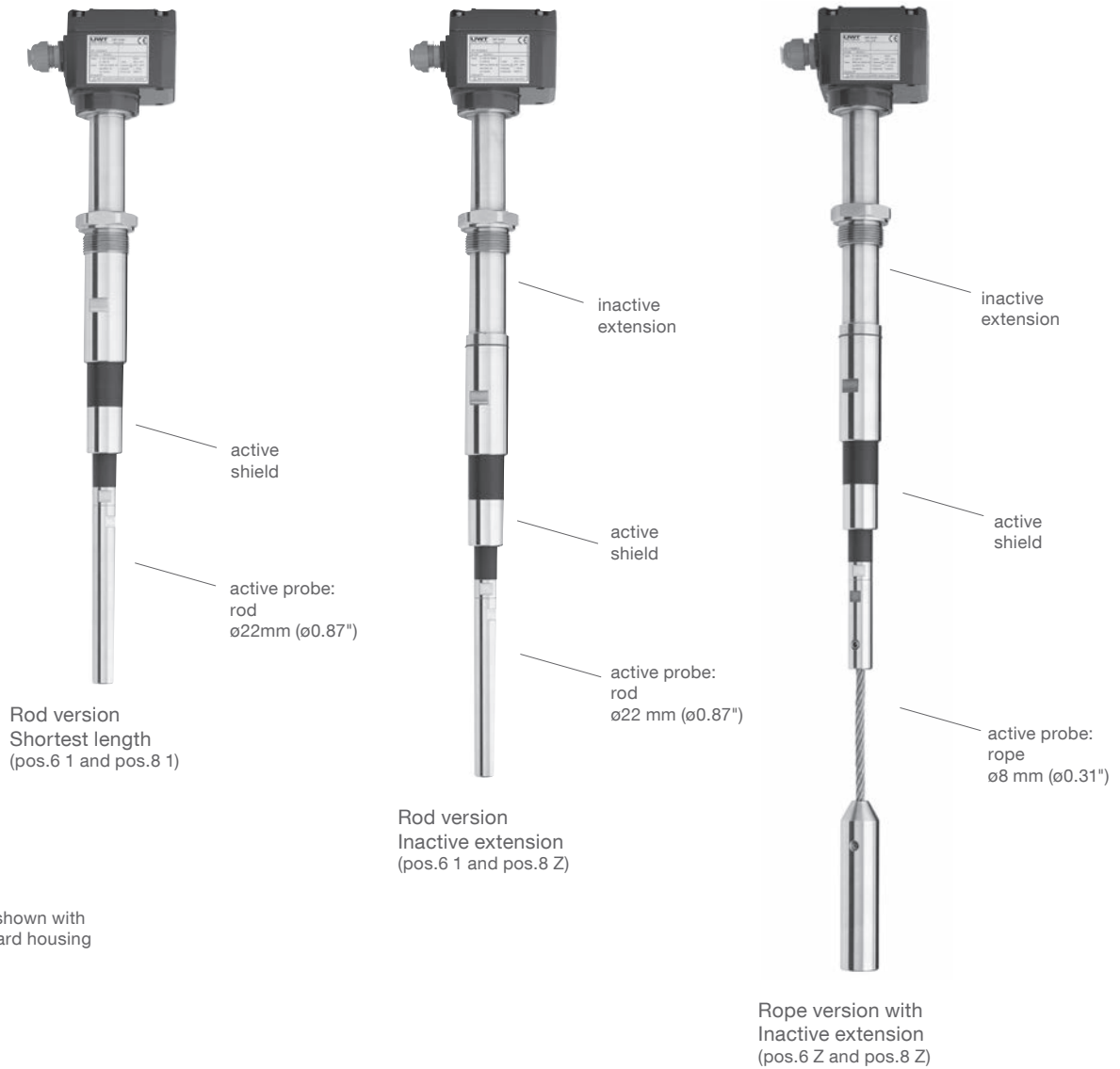

RF 3200 Heavy Duty version

Total length L	300 .. 2,500 mm (11.8 .. 98.4") rod 550 .. 20,000 mm (21.7 .. 787") rope
Active rod/ rope diameter	Rod \varnothing 22 mm (\varnothing 0.87") Rope \varnothing 8 mm (\varnothing 0.31")
Ambient temperature	-40 .. +70°C (-40 .. +158°F) Ex flameproof/XP +60°C (140°F)
Process temperature	-40 .. +240°C (-40 .. +464°F)
Process pressure	-1 .. +25 bar (-14.5 .. +363 psi)
Lateral load (rod version)	max. 90 Nm (\varnothing 22 mm probe), max. 525 Nm (\varnothing 33 mm pipe)
Tensile load (rope version)	max. 40 kN
Process connection material/ Extension material	1.4301/ 1.4305/ 1.4541 (SS303/ 304/ 321) or 1.4404/ 1.4401 (SS316L/ 316)
Probe isolation material	PPS reinforced FDA and 1935/2004/EC conform
Probe gasket material	FKM or FFKM

Length L1

Rod version,
horizontal mounting

DK*	L1 (pos.6)/ mm (inch)
<1.5	n.a.
\geq 1.6	\geq 300 (11.8")
\geq 1.8	\geq 200 (7.9")
\geq 2.2	\geq 100 (3.9")
\geq 10	\geq 50 (2.0")

*see external
DK table

With stated L1 the
unit works with
factory setted
sensitivity (2 pF).
For shorter L1 see
option pos.16

Switchpoint

Rope version

x mm (inch)
n.a.
\leq 300 (11.8")
\leq 200 (7.9")
\leq 100 (3.9")
\leq 50 (2.0")

The table states
the switchpoint
with factory
setted sensitivity
(2 pF). For smaller
x see option
pos.16

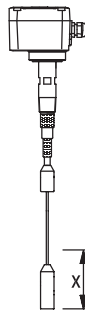

RF 3000 High Temperature version (500°C)

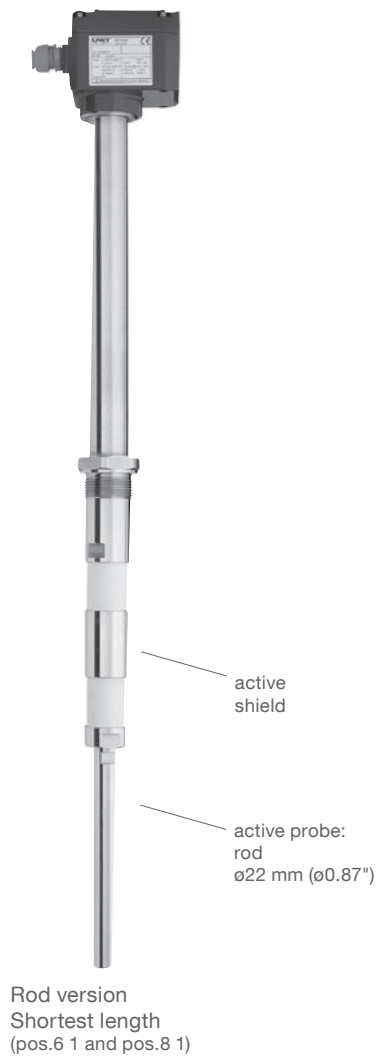

Units shown with
Standard housing

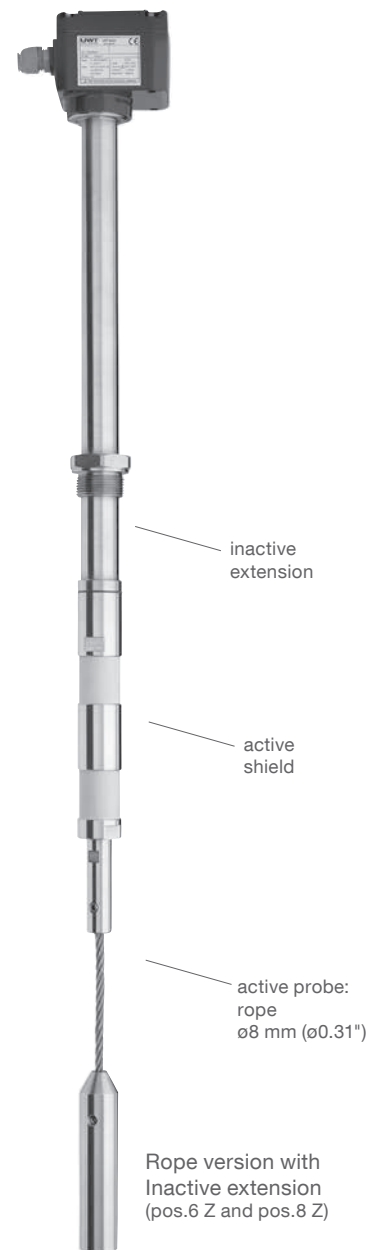
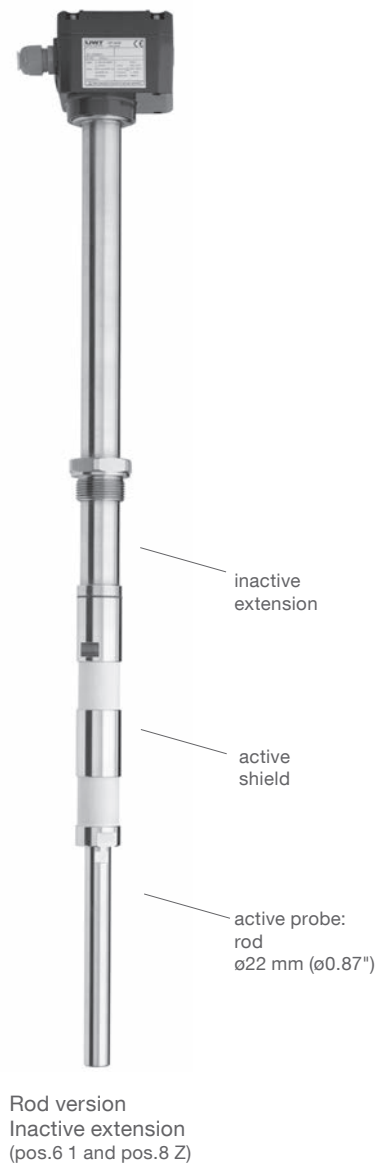

RF 3300 High Temperature version (500°C)

Total length L	320 ... 2,500 mm (12.6 .. 98.4") rod 570 .. 20,000 mm (22.4 .. 787") rope
Active rod/ rope diameter	Rod \varnothing 22 mm (\varnothing 0.39") Rope \varnothing 8 mm (\varnothing 0.16")
Ambient temperature	-40 .. +70°C (-40 .. +158°F) Ex flameproof/XP +60°C (140°F)
Process temperature	-40 .. +500°C (-40 .. +932°F) Ex versions: +445°C (833°F)
Process pressure	-1 .. +10bar (-14.5 .. +145 psi)
Lateral load (rod version)	max. 20 Nm (\varnothing 22 mm probe), max. 525 Nm (\varnothing 33 mm pipe)
Tensile load (rope version)	max. 10 kN
Process connection material/ Extension material	1.4301/ 1.4305/ 1.4541 (SS303/ 304/ 321) or 1.4404/ 1.4401 (SS316L/ 316)
Probe isolation material	Ceramic FDA and 1935/2004/EC conform
Probe gasket material	Graphite

Length L1 Rod version, horizontal mounting

DK*	L1 (pos.6)/ mm (inch)
<1.5	n.a.
\geq 1.6	\geq 300 (11.8")
\geq 1.8	\geq 200 (7.9")
\geq 2.2	\geq 100 (3.9")
\geq 10	\geq 50 (2.0")

*see external
DK table

With stated L1 the
unit works with
factory setted
sensitivity (2 pF).
For shorter L1 see
option pos.16

Switchpoint Rope version

x mm (inch)
n.a.
\leq 300 (11.8")
\leq 200 (7.9")
\leq 100 (3.9")
\leq 50 (2.0")

The table states
the switchpoint
with factory
setted sensitivity
(2 pF). For smaller
x see option
pos.16

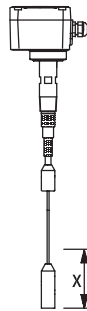

Options

Remote version

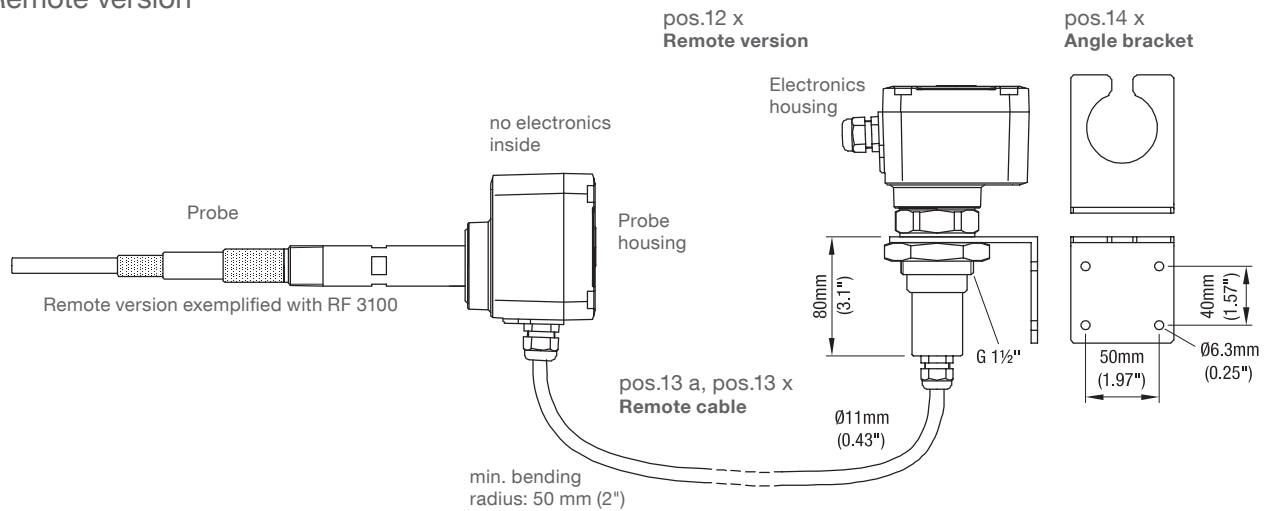

Probes

Extension kits for ø10 mm rod

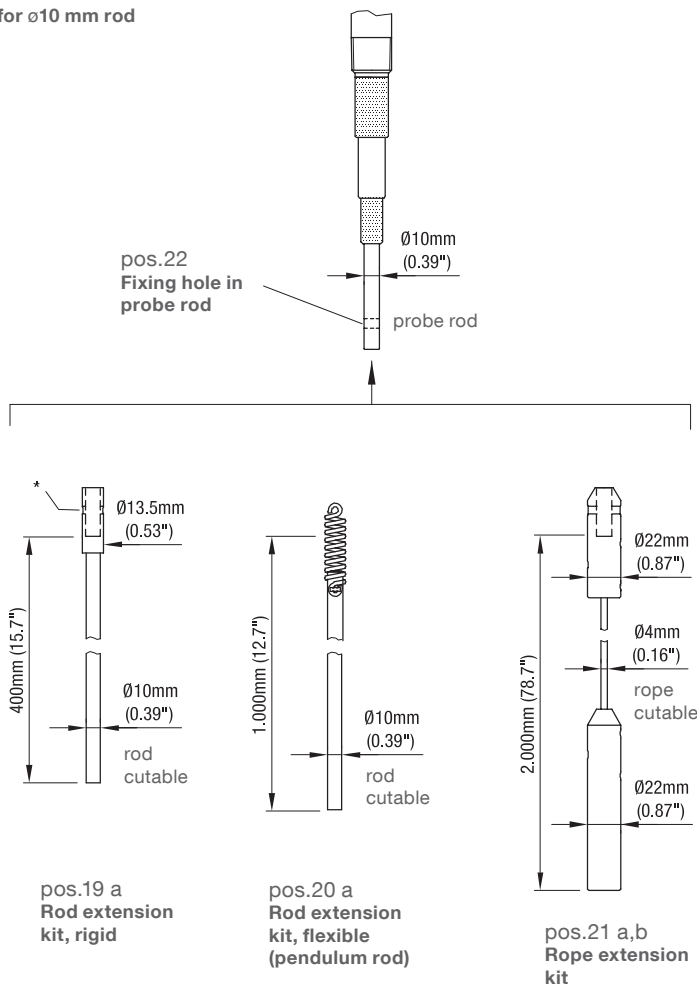

* Fixing by drilling a hole through the probe rod and fixing with a split pin

Extension kits for ø22 mm rod

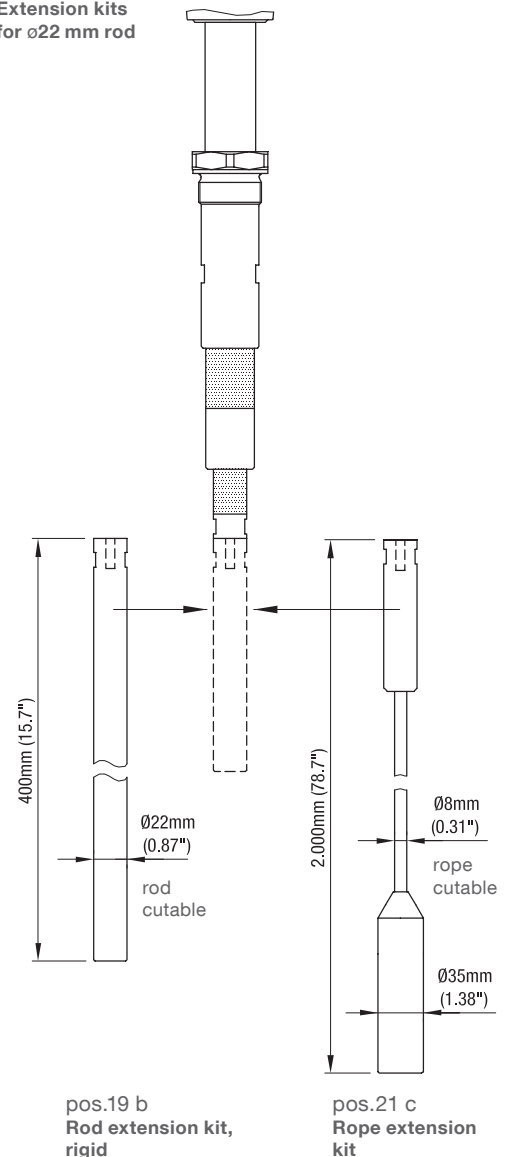

Options

Coatings

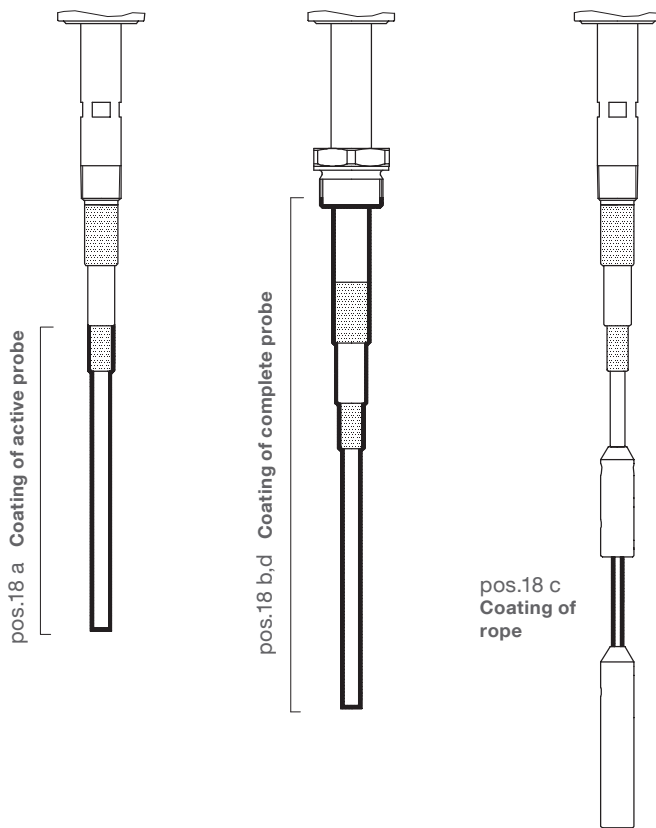

Mounting

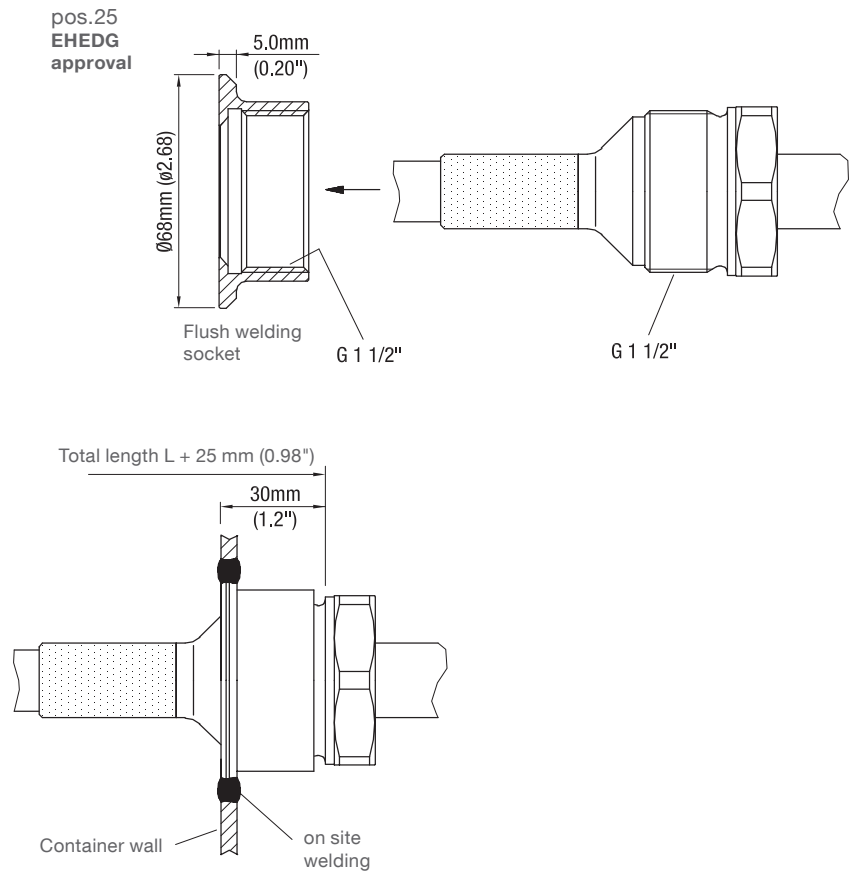
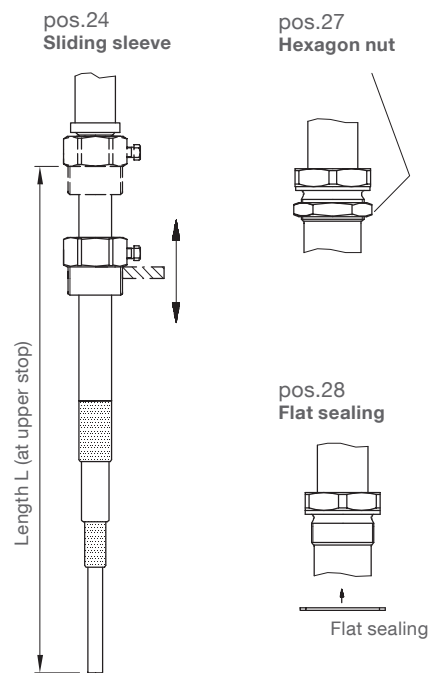

Options

Housing

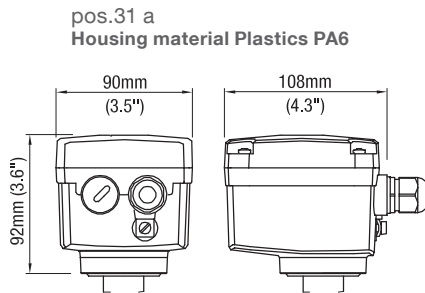

pos.32 x
Weather protection cover

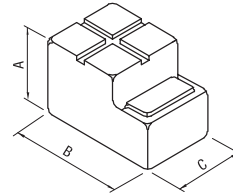

A	100 mm (3.94")
B	165 mm (6.5")
C	95 mm (3.7")

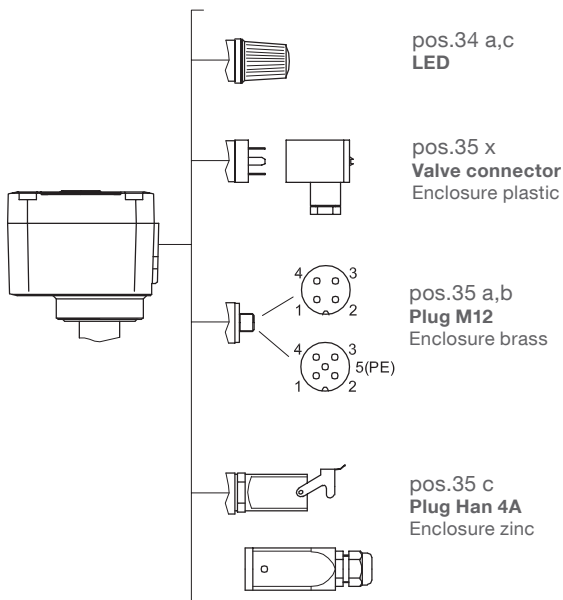

pos.34 d
LED (transparent lid section)

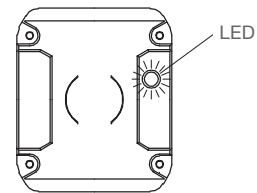

Dimensions

Housing versions

Standard

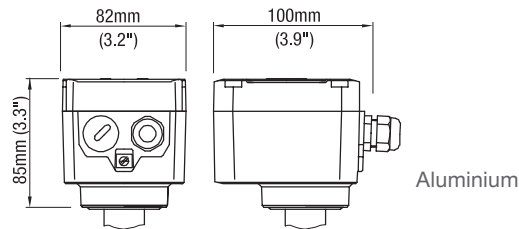

de

Explosionproof with increased safety terminal box

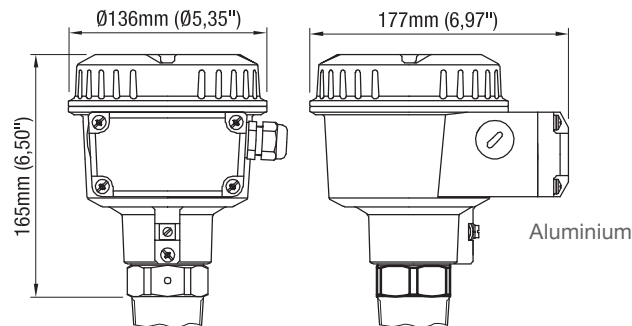

d

Flameproof/ explosionproof

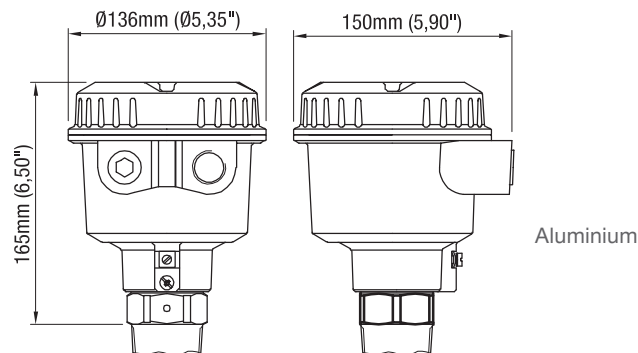

Dimensions

Probes

RF 3100 Standard version

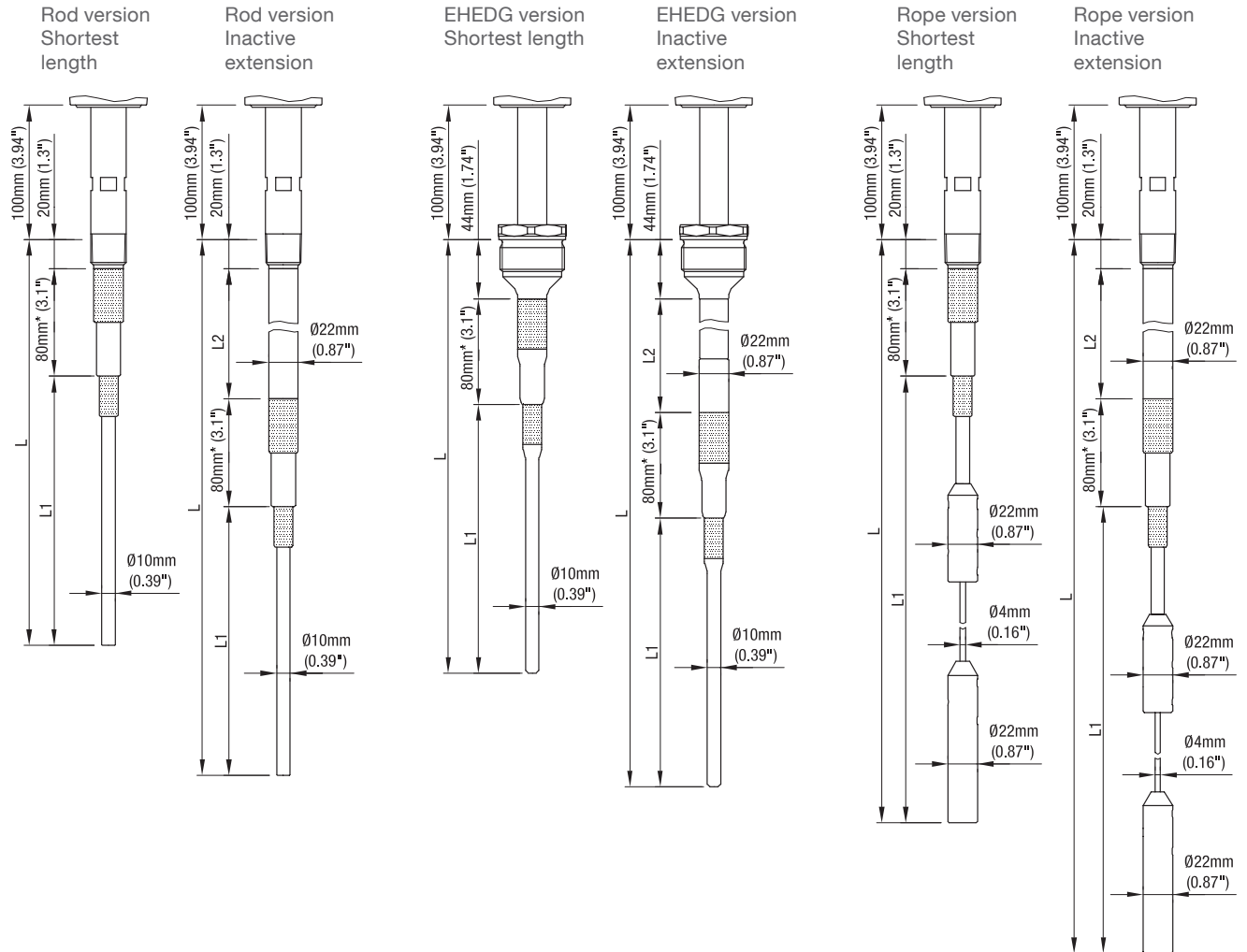

* Active shield

Only units with rod version are available with EHEDG Certificate. On rod versions with EHEDG Certificate the length "L" is increased by 25 mm (0.98").

Process connections:

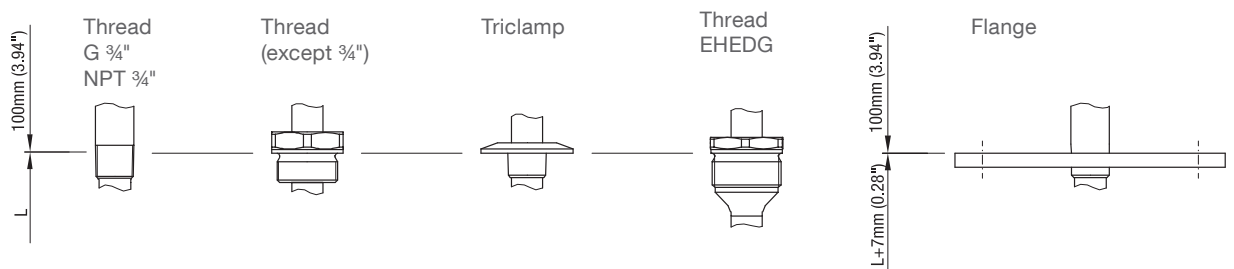

Dimensions

RF 3200 Heavy Duty version

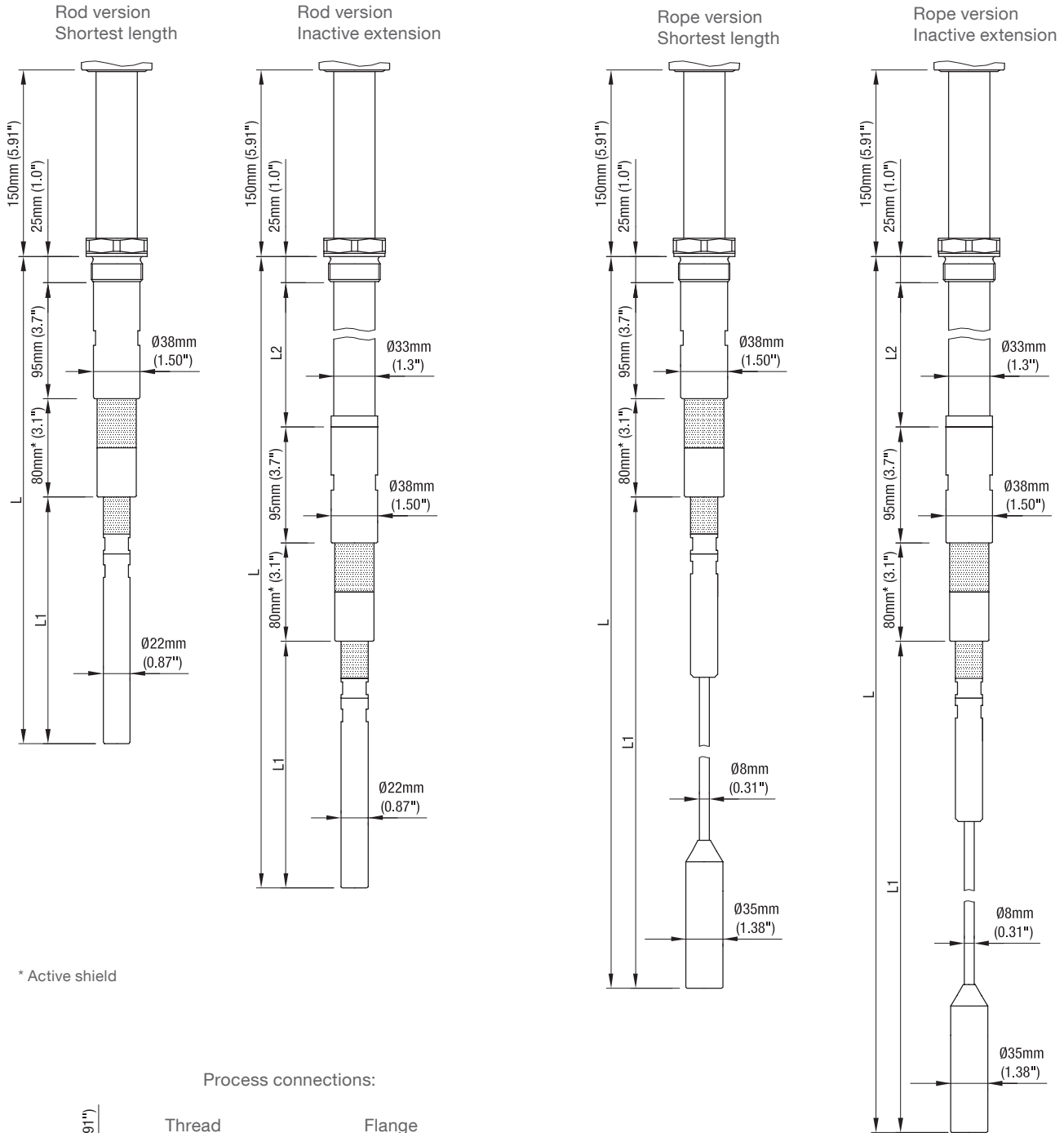

Dimensions

RF 3000 High temperature version

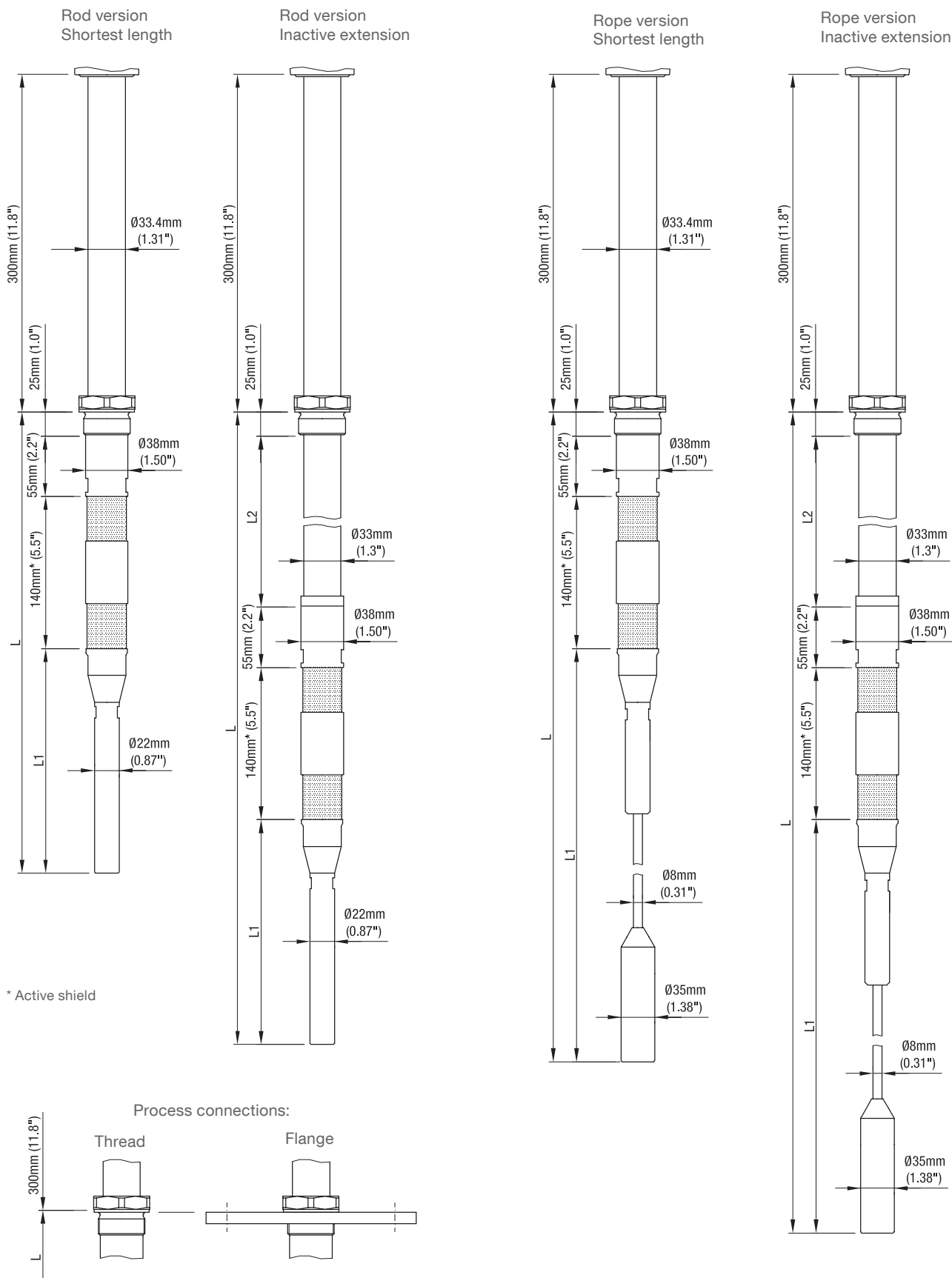

Dimensions

Flanges

Code	type	number of holes	d2	Lk	D	T (thickness)
L	Flange DN100 PN6	4	18 mm (0.71")	170 mm (6.69")	210 mm (8.27")	16 mm (0.63")
M	Flange DN100 PN16	8	18 mm (0.71")	180 mm (7.09")	220 mm (8.66")	20 mm (0.79")
S	Flange 2" 150lbs	4	19.1 mm (0.75")	120.7 mm (4.75")	152.4 mm (6.01")	19.1 mm (0.75")
T	Flange 3" 150lbs	4	19.1 mm (0.75")	152.4 mm (6.01")	190.5 mm (7.5")	23.9 mm (0.94")
U	Flange 4" 150lbs	8	19.1 mm (0.75")	190.5 mm (7.5")	228.6 mm (9.0")	23.9 mm (0.94")

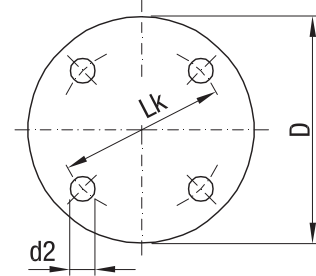

Detailed Ex-markings

Compact version (without pos.12 x)

Code	Certificate	Housing
pos.2 0	CE/ UKCA	Standard
pos.2 W	ATEX II 1/2D	Ex ia/tb IIIC T! Da/Db
pos.2 R	ATEX II 2G ATEX II 1/2D	Ex db eb ia IIC T! Gb Ex ia/tb IIIC T! Da/Db
pos.2 T	ATEX II 2G ATEX II 1/2D	Ex db ia IIC T! Gb Ex ia/tb IIIC T! Da/Db
pos.2 A	IEC	Ex ia/tb IIIC T! Da/Db
pos.2 C	IEC	Ex db eb ia IIC T! Gb Ex ia/tb IIIC T! Da/Db
pos.2 D	IEC	Ex db ia IIC T! Gb Ex ia/tb IIIC T! Da/Db
pos.2 M	FM/ FMc	General purpose
pos.2 N	FM	DIP-IS Cl. II, III Div.1 Gr. E,F,G
pos.2 U	FM	XP-IS Cl. I,II,III Div.1 Gr. B,C,D Cl. I Zone 1 Gr. IIB+H2 DIP-IS Cl. II, III Div.1 Gr. E,F,G
pos.2 E	TR-CU	Ex ia/tb IIIC T120°C...T445°C Da/Db X
pos.2 K	TR-CU	1Ex d e ia IIC T4...T1 Gb X Ex ia/tb IIIC T120°C...T445°C Da/Db X
pos.2 L	TR-CU	1Ex d ia IIC T4...T1 Gb X Ex ia/tb IIIC T120°C...T445°C Da/Db X
pos.2 2	+pos.15 b	KC
pos.2 5	+pos.15 b	KC
pos.2 2	+pos.15 c	CCC
pos.2 5	+pos.15 c	CCC
pos.2 2	+pos.15 e	UKEX II 1/2D
pos.2 4	+pos.15 e	UKEX II 2G UKEX II 1/2D
pos.2 5	+pos.15 e	UKEX II 2G UKEX II 1/2D

Remote Version (with pos.12 x)

Code	Certificate electronic housing	Electronic housing	Certificate Probe/ Probe housing
Pos.2 0	CE/ UKCA TR-CU	Standard	CE/ UKCA TR-CU
Pos.2 W	ATEX II 2D	Standard	ATEX II 1/2D Ex ia/tb IIIC T! Da/Db
Pos.2 R	ATEX II 2G ATEX II 2D	de	ATEX II 2G ATEX II 1/2D Ex ia IIC T! Gb and Ex ia/tb IIIC T! Da/Db
Pos.2 T	ATEX II 2G ATEX II 2D	d	ATEX II 1/2D Ex ia/tb IIIC T! Da/Db
Pos.2 A	IEC	Standard	IEC Ex ia/tb IIIC T! Da/Db
Pos.2 C	IEC	de	IEC Ex ia IIC T! Gb and Ex ia/tb IIIC T! Da/Db
Pos.2 D	IEC	d	IEC Ex ia IIC T! Gb and Ex ia/tb IIIC T! Da/Db
Pos.2 M	FM/ FMc	Standard	-
Pos.2 N	FM	Standard	FM DIP-IS Cl. II, III Div.1 Gr. E,F,G
Pos.2 U	FM	d	FM IS Cl. I Div.1 Gr. B,C,D and Cl. I Zone 1 Gr. IIB+H2 and DIP-IS Cl. II, III Div.1 Gr. E,F,G
Pos.2 E	TR-CU	Standard	TR-CU Ex ia/tb IIIC T80°C...T445°C Da/Db X
Pos.2 K	TR-CU	de	TR-CU 1Ex ia IIC T6...T1 Gb X Ex ia/tb IIIC T80°C...T445°C Da/Db X
Pos.2 L	TR-CU	d	TR-CU 1Ex d [ia] IIC T4 Gb X Ex ia/tb IIIC T120°C Db X
Pos.2 2 +Pos.15 c	CCC	Standard	CCC Ex ia/tb IIIC T! Da/Db
Pos.2 5 +Pos.15 c	CCC	d	CCC Ex ia IIC T! Gb Ex ia/tb IIIC T! Da/Db
Pos.2 2 +Pos.15 e	UKEX II 2D	Standard	UKEX II 1/2 D Ex ia/tb IIIC T! Da/Db
Pos.2 4 +Pos.15 e	UKEX II 2G UKEX II 2D	de	UKEX II 2G UKEX II 1/2D Ex ia IIC T! Gb and Ex ia/tb IIIC T! Da/Db
Pos.2 5 +Pos.15 e	UKEX II 2G UKEX II 2D	d	UKEX II 1/2D Ex ia/tb IIIC T! Da/Db

Electrical installation

Universal voltage

Relay DPDT

Power supply:

21 .. 230 V 50/60 Hz or DC $\pm 10\%$
 1.5 VA or 1.5 W

Fuse on power supply:
 max. 10 A, 250 V, HBC, fast or slow

Signal output:

Floating relay DPDT
 AC max. 250 V, 8 A, non inductive
 DC max. 30 V, 5 A, non inductive

Fuse on signal output:
 max. 10 A, 250 V, HBC, fast or slow

