

S-PT- 4S Smart Pressure Transmitter

User Manual

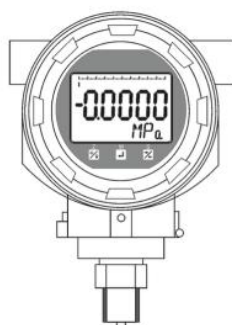
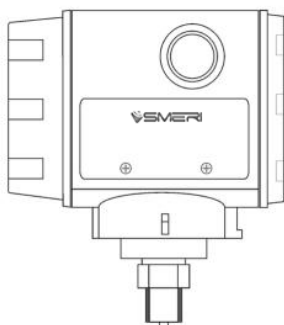

I. Introduction

S-PT-4S smart pressure transmitter is a versatile digital instrument. Based on advanced, mature, reliable silicon sensor technology, its design combines with advanced single-chip microcontroller (SCM) and sensor digital conversion techniques.

Its core component SCM has powerful function and high-speed computing capability, ensured high quality of the transmitter. The entire design focuses on reliability, stability, high accuracy and intelligence.

PT - 4S also has powerful interface operation function; its digital LCD can display pressure, pressure range percent, current and 0~100% analog indicating. Buttons on display can easily fulfil the basic parameters setting including zero migration, range changing, damping changing etc without standard pressure source, greatly facilitate on-site debugging.

Signal conversion, signal acquisition and processing, and current output controlling adopt dedicated integrated circuit (ASICs), so that the transmitter is accurate, stable and reliable.

II. Installation

S-PT-4S can be directly mounted on pressure pipe, or mounted by bracket (mounting bracket needs to be ordered).



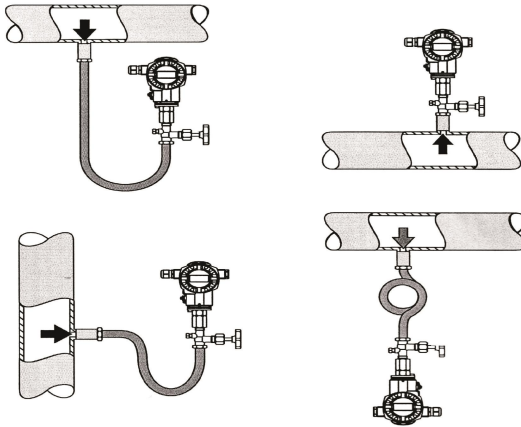

III. Electrical Connection

Unscrew cover of the wiring terminals to do wiring. Picture below shows the typical wiring way; TEST terminal is used to connect any indicating display or for testing. Supply power is with the signal line, without additional wiring.

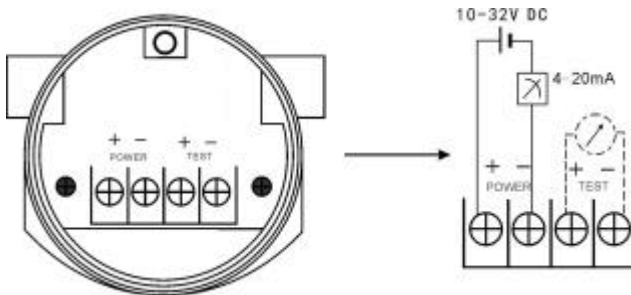

Attention:

Do not connect signal wire with power to the TEST terminals, which will destroy the diode of test terminals.

If the diode is damaged accidentally, short-circuit TEST terminal can resume working of transmitter, but the TEST terminals will not be able to connect with Ammeter.

V. Calibration & Operation

Unscrew cover of the other side.

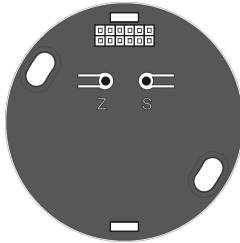

Without display

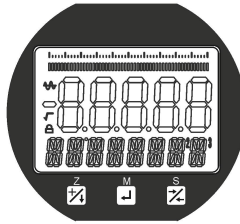

With display

4.1 Buttons operation for transmitter without LCD display

For transmitter without LCD display, buttons S and Z on circuit board can do below operations.

4.1.1 Reset

Ensure transmitter is electrified and under no pressure, press and hold S and Z simultaneously for over 3 seconds, then release the buttons simultaneously; press and hold the two buttons for about 3 seconds again, the current pressure value will be reset.

4.1.2 Lower range value calibration (LRV changing with pressure source)

Ensure the transmitter is electrified and pressed at lower range value (LRV), press and hold S and Z simultaneously for over 3 seconds, then release the two buttons at the same time; press and hold Z again for about 3 seconds, the current pressure will be transmitter LRV, but it does not change measuring range of the transmitter. For example: if the transmitter's range is 0~5kPa, the current pressure is -1kPa, after executing above operation, the transmitter range will be -1~4kPa.

4.1.2 Upper range value calibration (FRV calibrating with pressure source)



Ensure the transmitter is electrified and under pressure of upper range value (URV), press and hold S and Z at same time for over 3 seconds, then release

them at the same time; press and hold S again for about 3 seconds, the current pressure will be URV, but it will not change transmitter LRV. For example: the transmitter's range is 0~5kPa, the current pressure is 4kPa, after executing above operation, the transmitter range becomes 0-4kPa.

4.2 Button instruction of transmitter with LCD display

If transmitter is with LCD display, it can not only fulfil operations 4.1, but also parameters configuration by the three buttons on LCD display.

4.2.1 Buttons Description

Button pic	Name	Function
	S	In menu state, it is <u>Return</u> function; In parameter setting state, it is <u>Shift</u> function; the button also has the function of button S of 4.1 item.
	M	Menu and parameter <u>Confirm</u> function.
	Z	In menu state, it is <u>Choose</u> function; In parameter setting state, it means ± 1 ; The button also has function of button Z of 4.1 item.

4.2.2 Menu structure

When transmitter is electrified, long press M button to enter parameter setting menu.

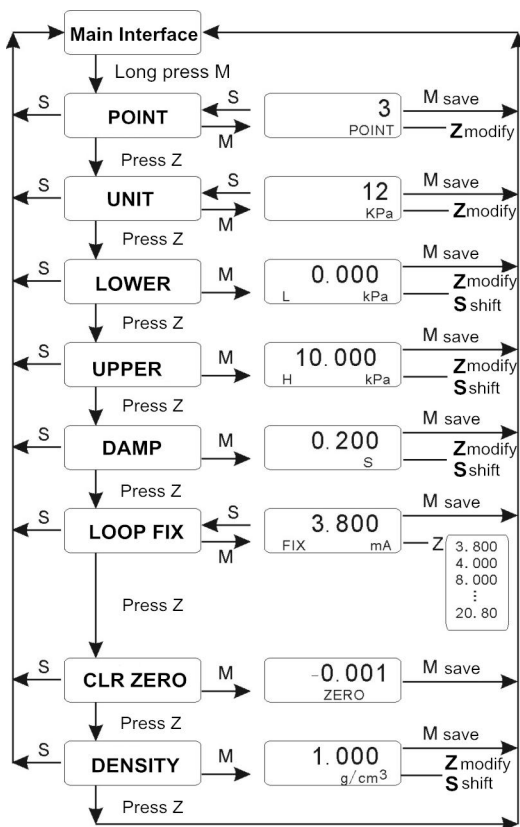

4.2.3 Configuring Examples

Change LRV

- At main measurement interface, long press M to enter menu selection mode, the display blinks POINT. If press S at this time, it will exit setting and return to measurement display state;
- Press Z till the LCD shows LOWER with blink, press M to start LRV setting;

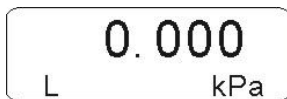

- Then press S to change the modifying digit, press Z to +1 for the selected digit; press M to save the setting and return to the main measurement interface.

Note:

1. When decimal point is selected, it will flash, press Z to move the decimal point circularly;
2. When negative sign is selected, it will flash, press Z to change the negative sign state; when the negative sign is valid, it will speed up flashing; if it is invalid, flashing slows down.

4.2.4 Density Setting Instruction

Density setting is only valid for units m and mm. Main variable value, LRV and URV can be calculated as per below formula.

- When unit is m:

$$h=P/(\rho *g)$$

h: height (unit: m);

P: measuring pressure value (unit: kPa);

ρ :density (unit: g/cm^3);

g: 9.80665;

- When unit is mm:

$$h=1000*P/(\rho *g)$$

h: height(unit:mm);

P: measuring pressure value (unit: kPa);

ρ :density (unit: g/cm^3);

g: 9.80665

4.2.5 Reset to defaults

If error or disorder occurs during transmitter parameters setting, users can use buttons on display to reset to defaults, and reset parameters according to the actual usage conditions. Detailed method is as below:

- Enter damping time (DAMP) parameter setting state, set damp as

"801.xx" by buttons (x: any digit);

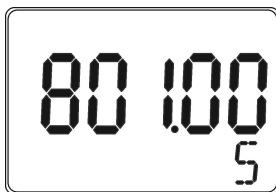

- Press M to confirm, transmitter will be reset to defaults;
- The damping time "801.xx" is actually not saved because the valid range of damping time is 0-64 seconds;
- Reset parameters according to actual usage conditions.

4.2.6 Additional Notes

When transmitter is in parameter setting state, if no button is pressed for about 30 seconds, it will automatically return to main measuring status, the parameters displayed will not be saved.

SMERI s.r.l.

Via Mario Idiomi 3/13

I - 20057 Assago MI

Tel. +39 02 539 8941

E-mail: smeri@smeri.com - www.smeri.com

