

MINIRADAR

**S-810-L / S-810-EL / S-811-L / S-800-RL
S-800-S-BT**

RADAR LEVEL SENSORS



OPERATING MANUAL Local & Wireless setup

See also the SERVICE pages on SMERI
website: tutorial for wireless programming



SERVICE - TUTORIAL

TABLE OF CONTENTS

1.	Warranty and service scope of radar.....	3
2.	Unpacking inspection and precautions.....	4
3.	Storage and transportation.....	4
4.	Product introduction.....	5
5.	Installation.....	11
6.	Radar wireless operation.....	14
7.	Radar local operation.....	24
8.	Radar Modbus communication.....	30
9.	Maintenance.....	36
10.	Fault handling.....	37

1. Warranty and service scope of radar

The warranty period of the radar level sensor is one year. This warranty is only limited to the users of the original buyer or the designated dealer, and does not apply to users who use it wrongly for human reasons, transform, neglect or damage it due to accidents and abnormal use.

For the faulty radar level sensor returned within the scope of warranty, free maintenance is provided. To obtain warranty service, please contact the after-sales service department and attach the fault description. With the permission of our company, send the radar sensor to the after-sales service department.

If the radar level sensor has expired the warranty period or it is confirmed that the failure is caused by misuse, modification, negligence, accident and abnormal conditions, the maintenance cost budget will be provided according to the relevant maintenance charge standard, and the maintenance will be carried out after it is approved. After the radar level sensor is repaired, it is sent back to the customer, and the customer needs to pay the maintenance and transportation costs.

2. Unpacking inspection and precautions

2.1 Unpacking inspection

- Instruction manual
- Certificate of conformity
- Packing list
- Radar Level Sensor
- Check the name, model and other contents on the nameplate
- Check whether the radar sensor housing is intact and observe
- Check the random items against the packing list
- Check whether the specifications, models and accessories are correct and complete according to the packing list of the radar level sensor. If there is any problem, please contact the customer service center in time for replacement.

2.2 Precautions

- Please read this manual before installing the radar level sensor.
- Modifications due to product upgrading are subject to change without notice. Please refer to the real object.

3. Storage and transportation

3.1 Storage conditions

- Temperature:
MINIRADAR for solids: $-40\dots+85$ °C model G3 / $-30\dots+80$ °C model G2 / model HT up to 200°C
for liquids: $-20\dots+70$ °C / $-40\dots+85$ °C model in PVDF
- Use the original packaging

3.2 Transport the product to the measuring place

- Use the original packaging to transport the radar sensor to the measuring place.
- Collision, dampness and chemical erosion shall be prevented during transportation and storage.

4. Product introduction

4.1 Product Overview

77-81Ghz frequency modulated continuous wave (FMCW) radar products (also known as millimeter wave radar) adopt the millimeter wave band with higher frequency than Ku band radar. They have important applications in long-range target detection, long-range imaging, multispectral imaging in strong smoke and dust environment, and can detect smaller targets than microwave radar and achieve more accurate positioning, with higher resolution and stronger confidentiality.

As a 80GHz band radar used in the field of industrial measurement, high-precision, non-contact level. This level measurement principle has incomparable advantages over other ordinary microwave pulse radars and guided wave radars. With extremely narrow beam and penetration ability, it can better adapt to ultra complex working conditions without weakening the measurement performance.

4.1 Technical Parameters

Medium

In general, the dielectric constant of the measured medium is required to be greater than 2, so that it can have a good reflection section.

Ambient temperature: it is recommended to use the instrument protection box in the northern area. In areas with strong direct sunlight, it is recommended to install the instrument in a cool place or use a sun visor, so as to avoid excessive temperature in the instrument caused by exposure to the sun, and to provide good ventilation and heat dissipation.

MINIRADAR S-810-L/S-810-EL/S-811-L/S-800-RL

TECHNICAL DATA	
Housing	PVDF, PTFE , GFPP, PBT+GF or SS304 Lens,
Antenna	PP
Beam angle	3° - 3,5°
Measuring range	Depends on the model, up to 30 m
Accuracy	±5 mm (10 m) / ±12 mm (20 m) / ±15 mm (30 m) (±2 mm model in PVDF)
Signal output	4-20 mA, RS485. Modbus, Bluetooth
Power supply	24 Vdc (18...30 V)
Process temperature	-20...+70 °C (-40...+85 °C model in PVDF)
Working pressure	-1...+3 bar
Humidity	0...95% RH
Protection level	IP65/66/67/IP68 depends on the model
Electrical connection	S-810-L/S-810-EL/S-811-L: shielded cable outlet in PUR, 1 m standard, others on request S-800-RL: double M12×1.5 cable gland
Operation	App RadarMe on smartphone (Bluetooth)

4.1 Technical Parameters

MINIRADAR S-800-S-BT

TECNICAL DATA	
Measuring range	Model G2: 30 m Model G3: 30 m and 60 m
Communication	Two wire system, Bluetooth
Output signal	4-20mA, RS48 (Modbus), HART
Accuracy	±2 mm
Antenna	SS304-SS16/PTFE
Process connection	Thread G2" (model G2) Thread G3" (model G3) Customized flanges and threads
Beam angle	±2,9° (model G3); ±3,5° (model G2)
Power supply	Two wire, 24 Vdc (22...30 V)
Process temperature	Model G2: -30...+80 °C; G3: -40...+85 °C Model HT up to 200°C
Process pressure	Atmospheric pressure
Protection level	IP67

4.2 Outer Dimensions

Unit: mm

S-810-L : stainless steel 304,
thread, flange connection

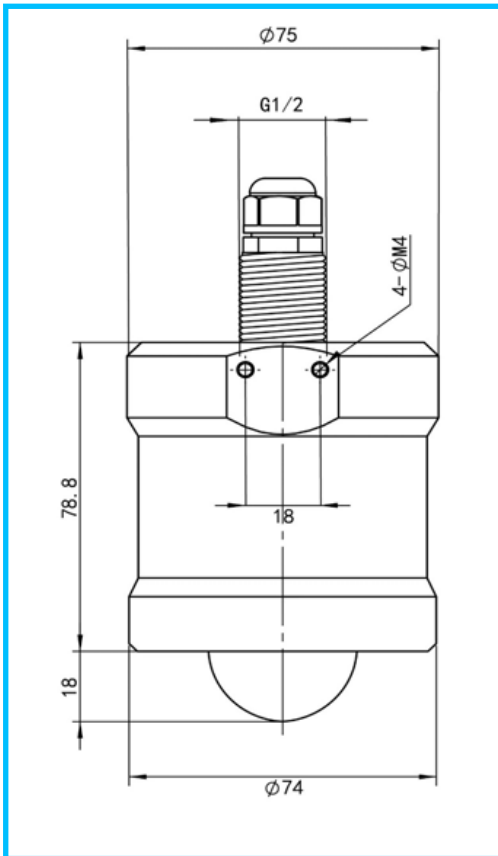

S-811-L : GFPP,
thread, flange connection

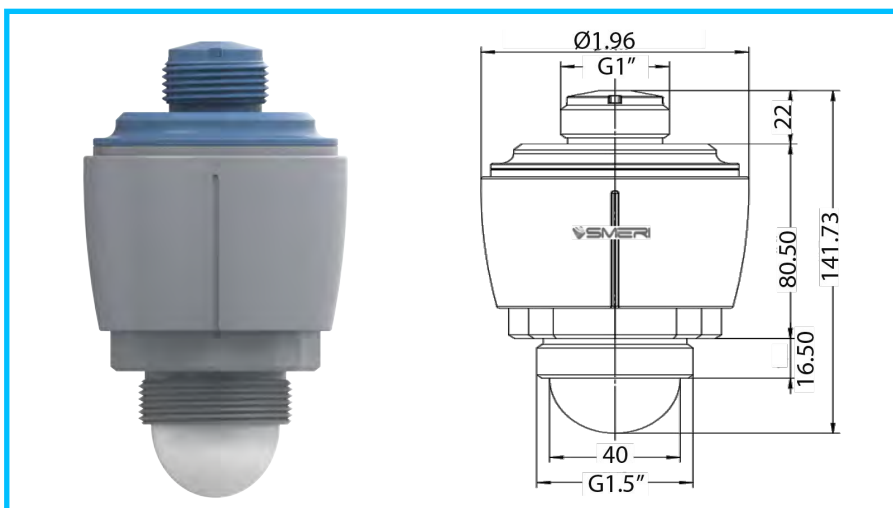

4.2 Outer Dimensions

Unit:mm

S-800-RL : PBT+GF, threaded connection

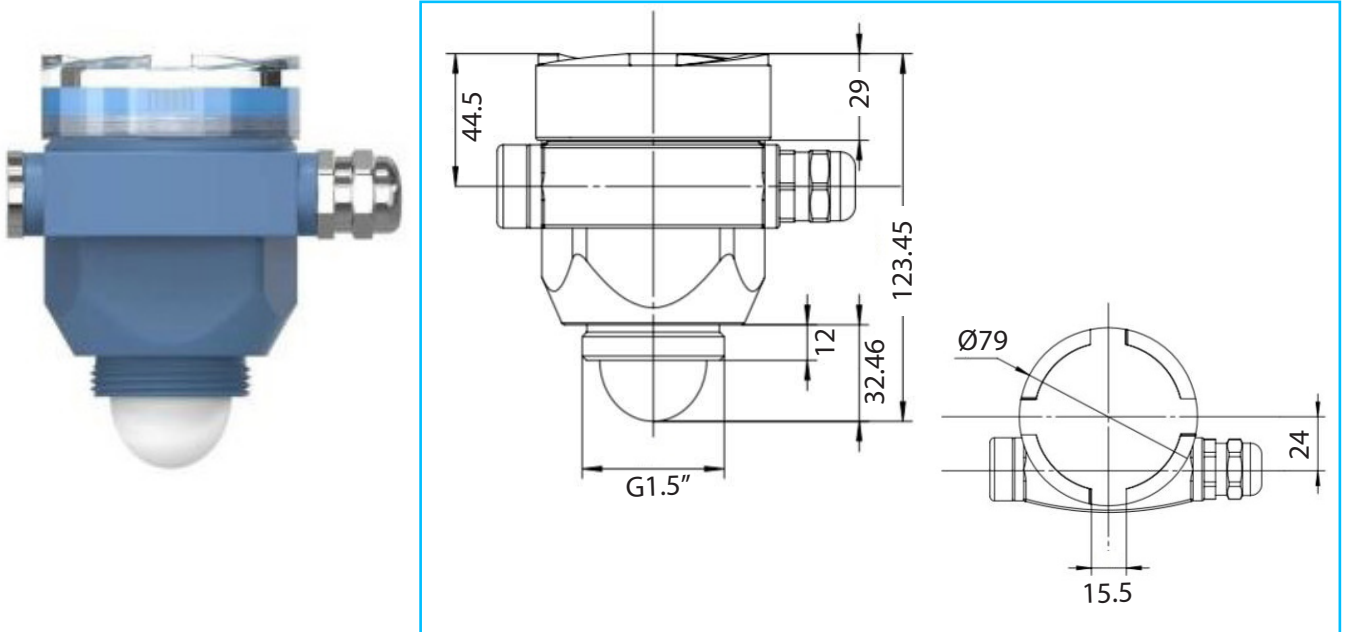

S-810-EL : PVDF, PTFE, threaded connection

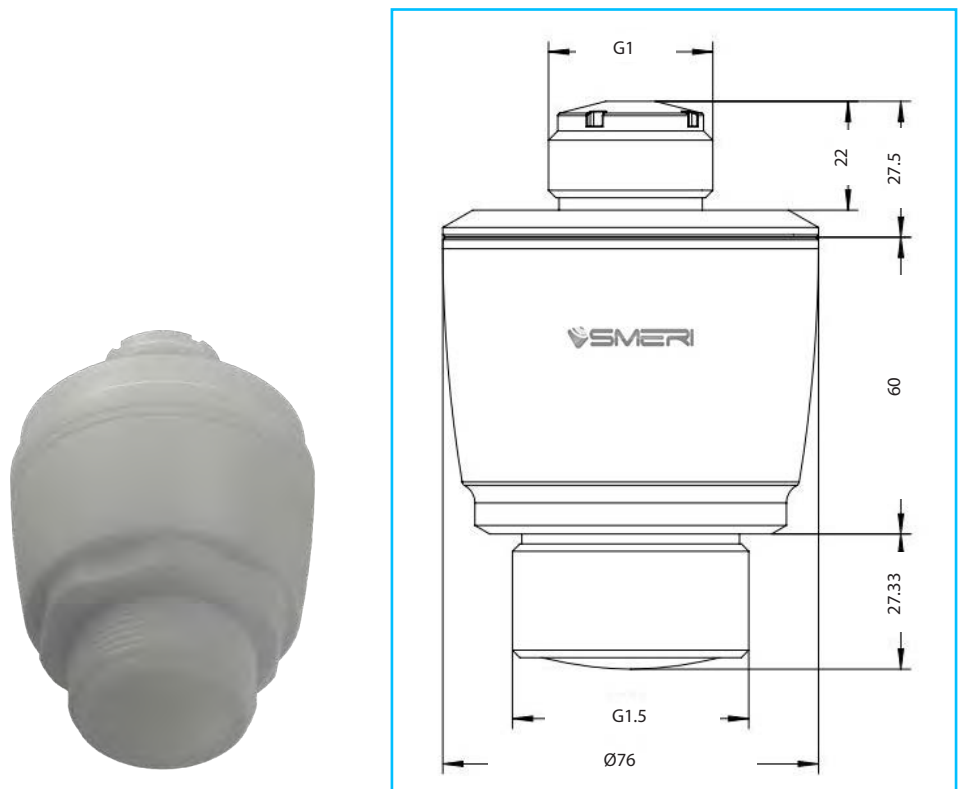

4.2 Outer Dimensions

Unit:mm

MINIRADAR S-800-S-BT

MODEL G2 - THREAD G2"

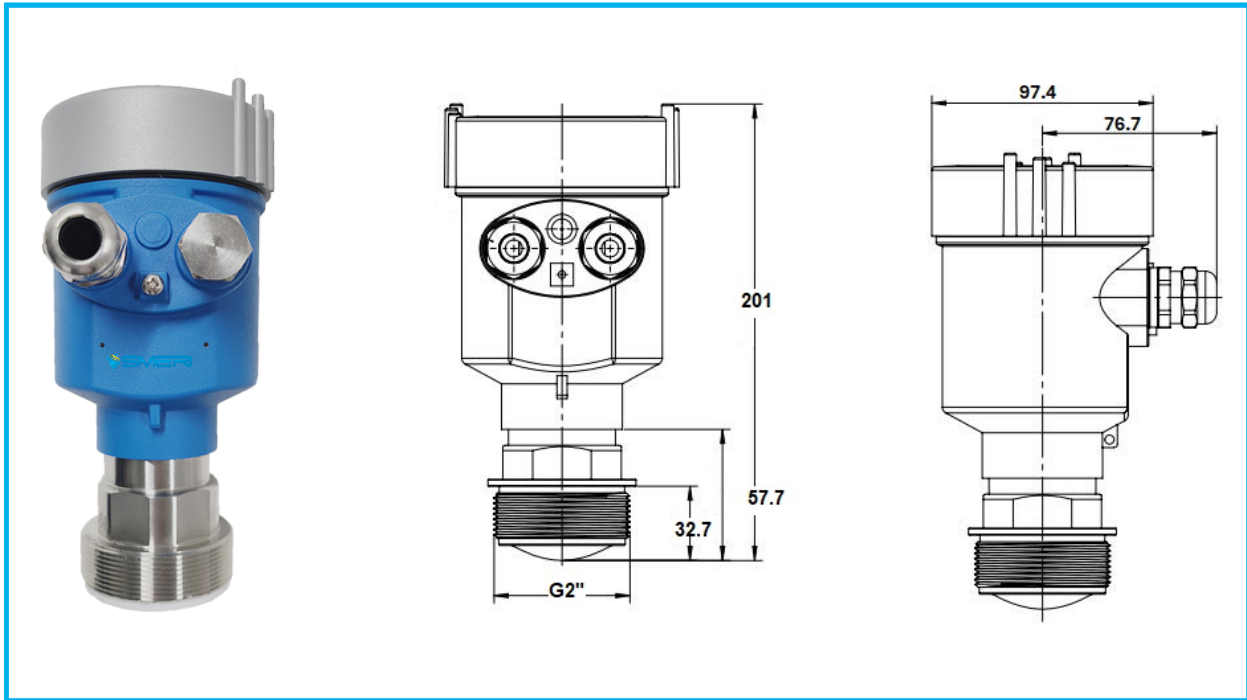

MODEL G3 - THREAD G3"

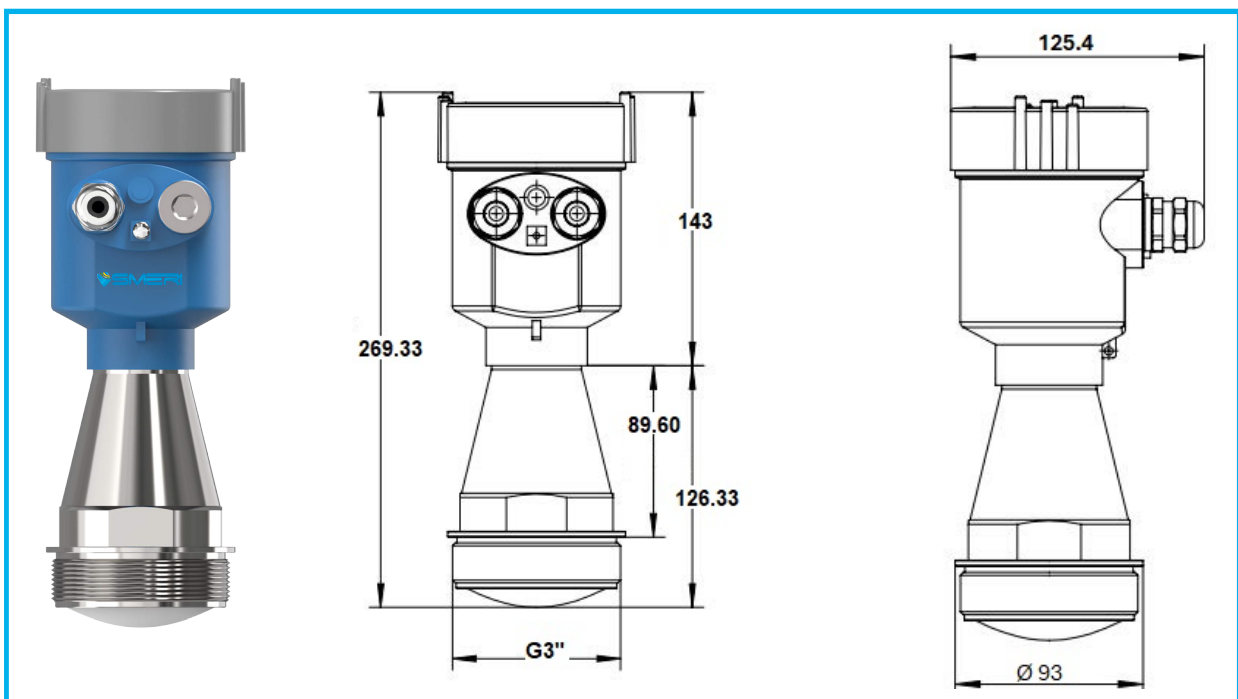

5. Installation

Two points need to be paid attention to during installation:

(1) Ensure that the meter is perpendicular to the water surface (2) Avoid the emission beam irradiating the interference object and generating false echoes.

Please check the following points for typical operating conditions.

- Ensure that the water level sensor is installed perpendicular to the water surface, and the tilt will weaken the received signal amplitude and affect the normal ranging.
- The installation of the instrument should be at least 20cm away from the side wall, and the installation of the underground pipe network should be as close to the center of the water well as possible, otherwise the well wall will easily generate interference signals, which will affect the measurement and judgment, as shown in the figure below.

Preparation before installation

- Understand the internal structure and pipeline arrangement of the storage tank, and obtain information such as the diameter and range of the tank.
- Tools needed: flat-blade screwdriver (3*75mm), wire stripper (7mm²), hand knife, pipe wrench, DC 24V power supply.
- Open channel installation Make sure that there are no interfering objects within the beam range, such as river banks.

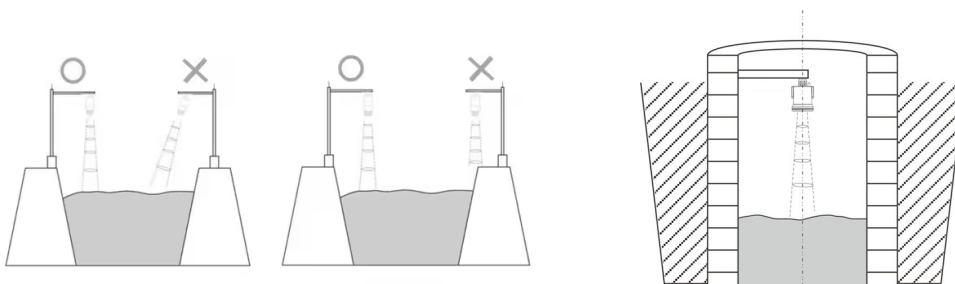

LOCATION SELECTION

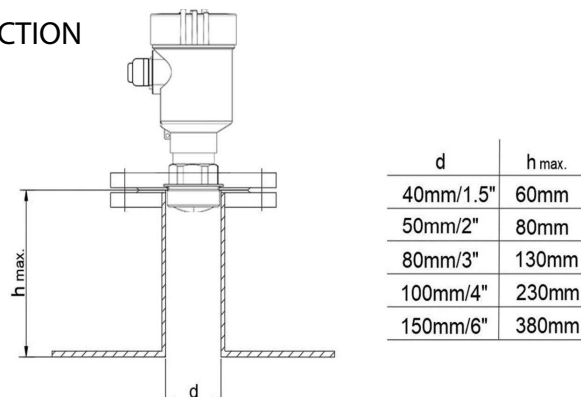

- Avoid installing the radar in a central location or close to the edge of the container

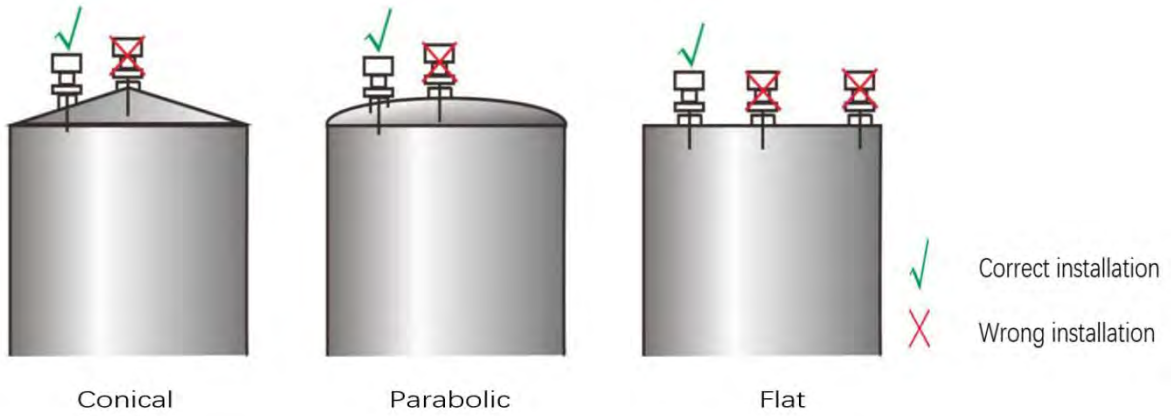

- Avoid false wave diagram

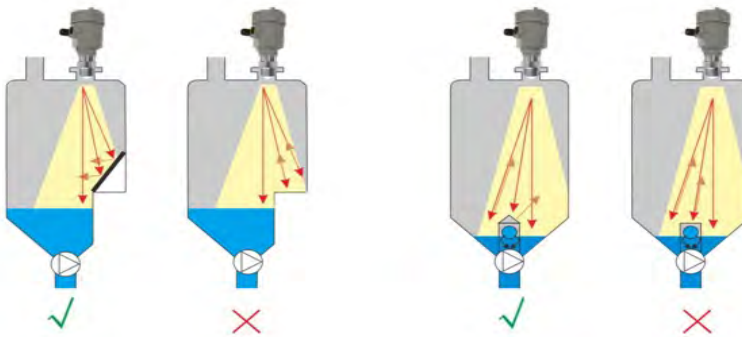

- Treatment of stairs and grille tanks

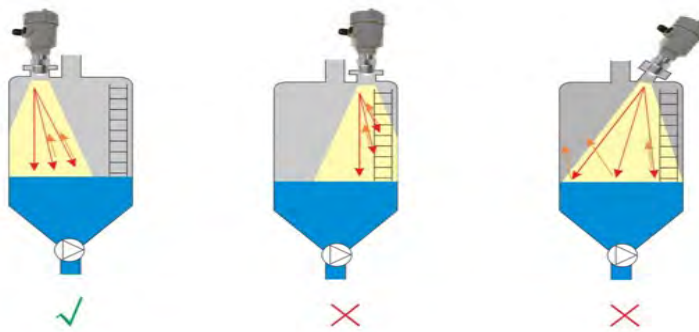

- Treatment of wall hanging and grille tanks

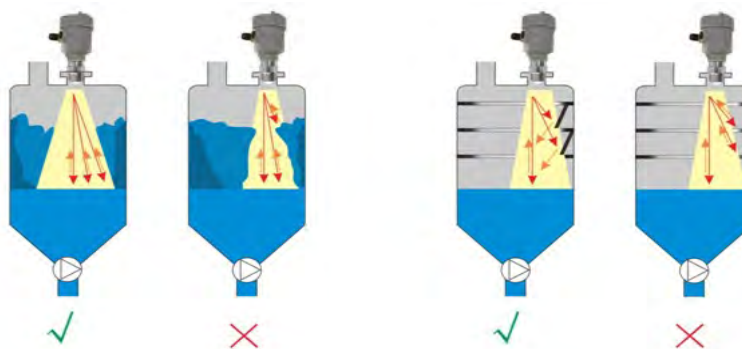

Wiring

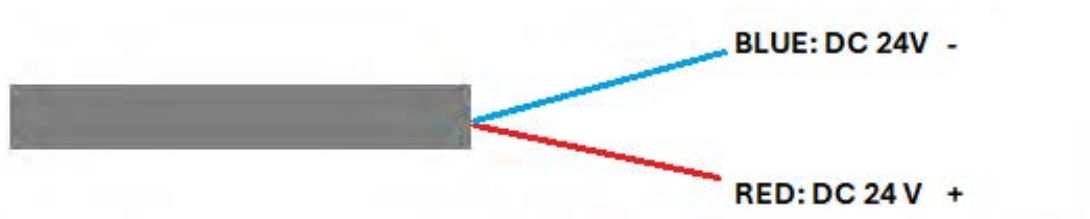

Model S-810-L / S-810-EL / S-811-L: comes with a 10m shielded cable output with two conductors; the red core is connected to the positive terminal of the power supply, while the black core is connected to the negative terminal.

Model S-812-L: is equipped with two M12x1.5 cable glands and an internal terminal block.

CONDUCTOR/TERMINAL	
RED (+)	24V DC positive pole
BLUE (-)	24V DC negative pole
RS-485 (+)	RS-485 positive pole
RS-485 (-)	RS-485 negative pole

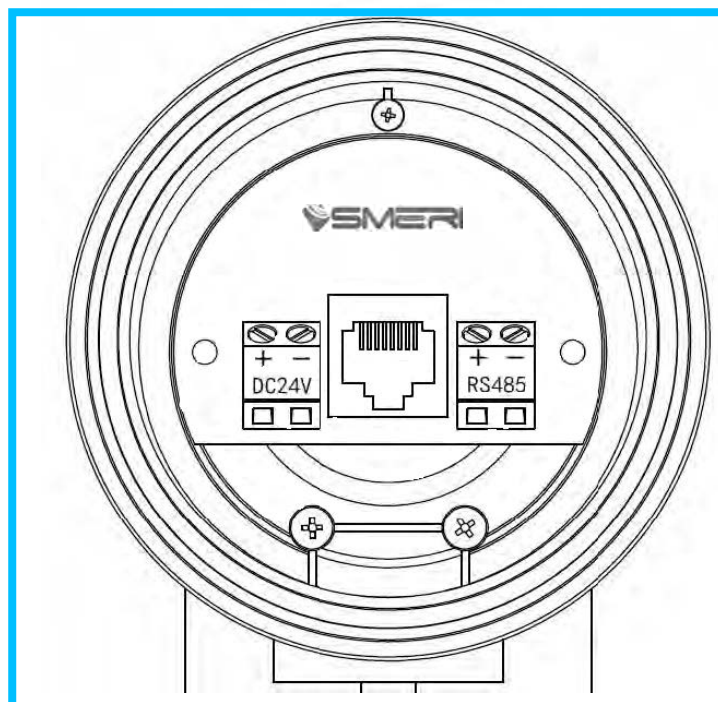

6. Radar wireless operation

Debugging and setting

MINIRADARs performs level measurement tasks according to the settings, which can be modified via Bluetooth and APP on mobile.

App RadarMe on Play Store for Android/Apple

See also the SERVICE pages on SMERI website: tutorial for wireless programming

Software Setting

Open the APP in the Mobile Phone to display the device connection interface, as shown in the figure below:

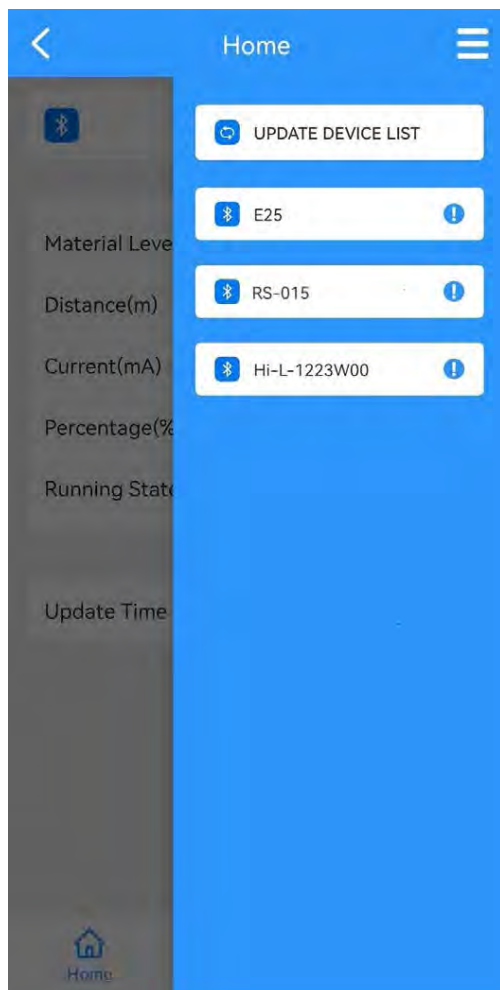

Click the name of the device to be set to enter the main interface, as shown in the figure.

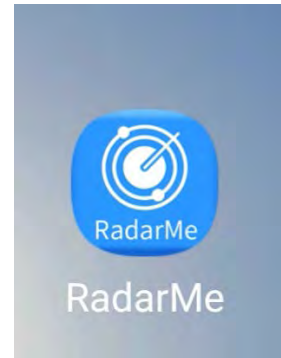

SERVICE - TUTORIAL

Main interface

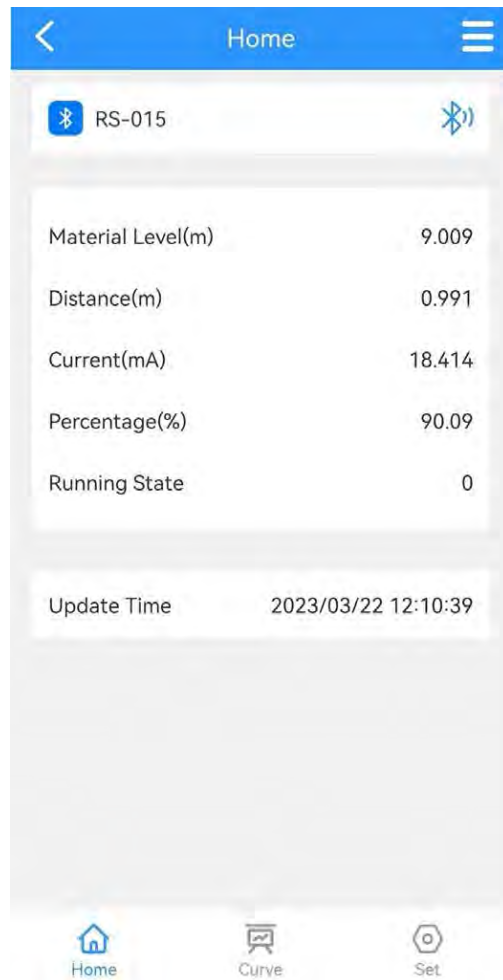

Home

Material Level: level value of the product

Distance: from sensor to the product surface.

Current: analog signal output corresponding to product level

Percentage: percentage of liquid/solids level and max range

Running State: working stage = 0 is work well, = 1 is error.

Click the "Curve" button at the bottom of the screen to enter the echo curve interface, as shown in the following figure.

Echo Curve Interface

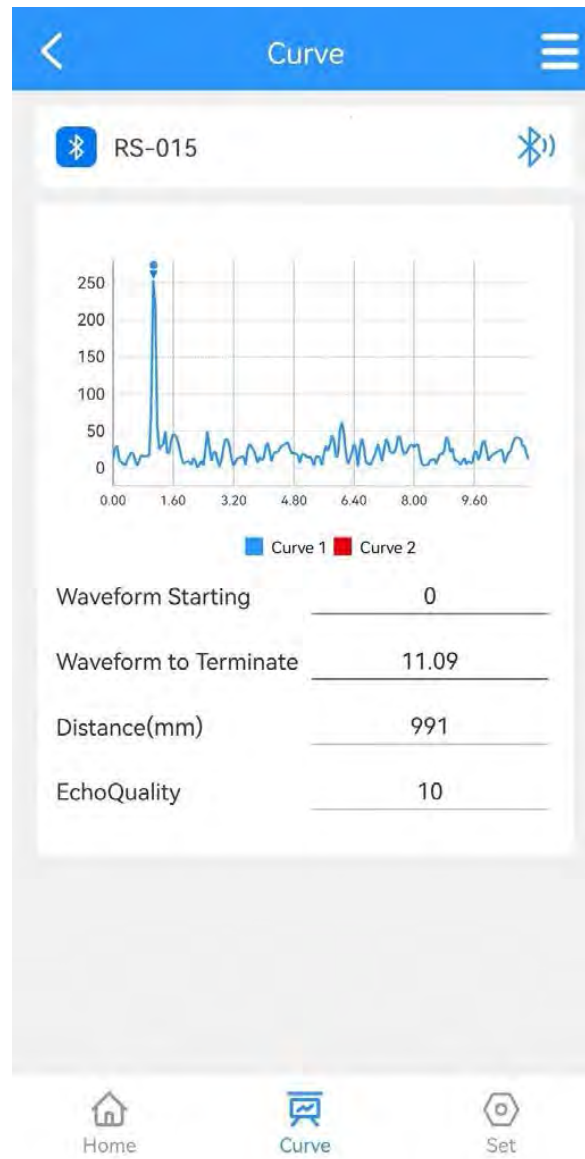

Waveform Starting: starting position of the waveform

Waveform to terminate: stopping position of the waveform

Distance: from radar sensor to the product surface.

Echo Quality: quality of echo, unit is DB.

Click the “Set” button at the bottom of the screen to enter the parameter setting interface, as shown in the next figure.

Setting

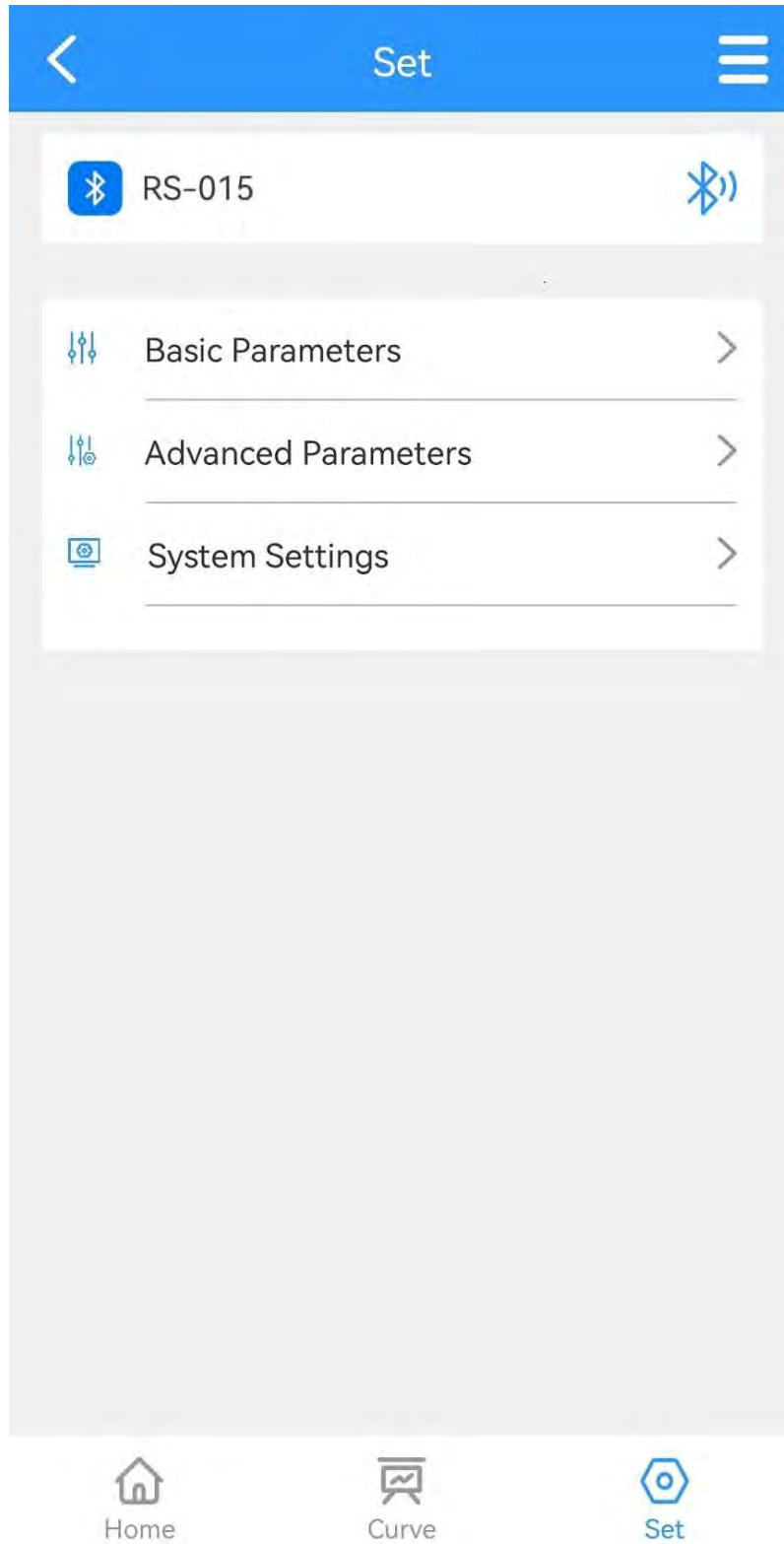

Basic Parameters

Click “Basic parameters” on the interface to open the menu below:

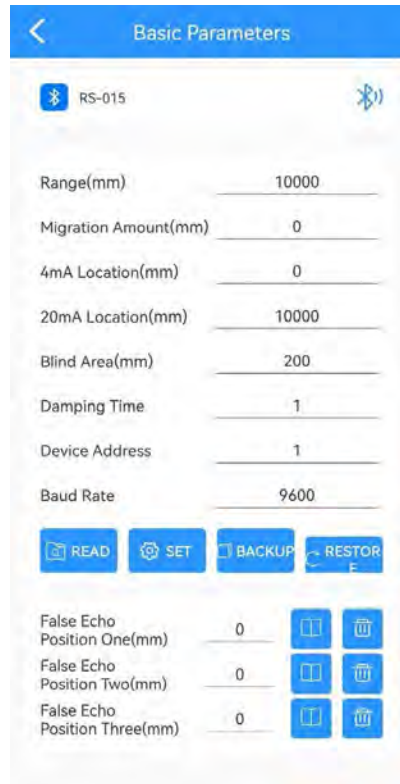

Set the “Range” according to the working conditions and directly click the number input box behind to modify it.

The rest of the parameters are modified in the same way.

Click the “ Read” button to refresh the parameters.

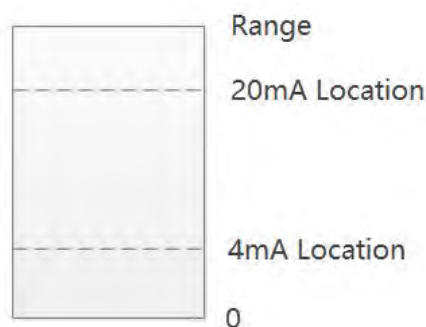

As shown in the figure, when the level is lower than 4mA Location, the main interface displays the level as 0;

when the product level is higher than the 20mA Location, the main interface displays the level value as the value of 20mA Location.

Basic Parameters

Range: max. distance to 0%, (container height)

Migration Amount: never put any value

4mA Location: lowest part o the measure 0% (usually 0 meter)

20mA Location: total mearuring range 100% (usually range <-> blind)

Blind Area: distance where there is no echo evaluation

EXAMPLE

Silo height 10.000 mm, range 9500 mm

Range: 10.000 mm

Migration Amount: never put any value (0)

4mA Location: 0

20mA Location: 9500 mm

Blind Area: 400 mm

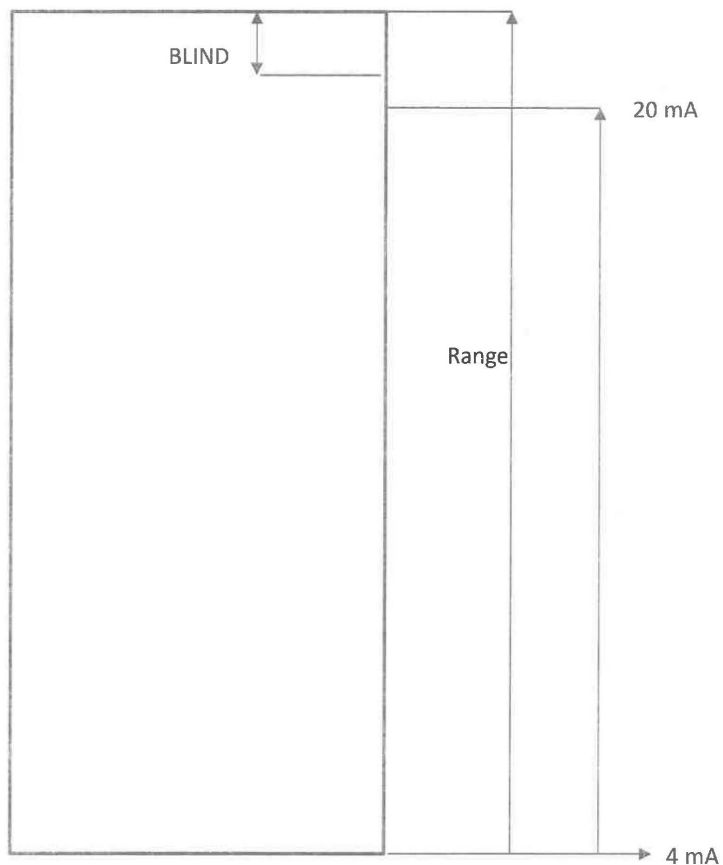

Basic Parameters

Damping Time: speed at which the actual product level is displayed on screen.

The longer the damping time value, the slower the response.

Device Address: device No, can be modified.

Baud Rate: default Baud Rate is 9600

False Echo Position One: location of the first false echo. If you know the location of the obstacle and enter the level value, the system will automatically block this false echo.

False Echo Position Two: location of the second false echo. If you know the location of the obstacle and enter the level value, the system will automatically block this false echo.

False Echo Position Three: location of the third false echo. If you know the location of the obstacle and enter the level value, the system will automatically block this false echo.

Advanced Parameters

10:16
3.00 KB/s HD HD 5G 89%

< Advanced Parameters

RS-015

Current Simulation(mA) 0

Working Location Number **RS-015**

READ

SET

Threshold Value	5
Threshold Amplitude	10
Echo Window	5000
Rate of Level Change	36000
Fixed Offset	-94
Gain Mode	0
Gain One	1
Gain Two	24
False Wave Threshold	200
Echo Width	15

Advanced Parameters

Threshold Value: setting parameters used to distinguish between signals and noise. It is recommended to use default parameters. If you have any requirements, please contact SMERI.

Threshold Amplitude: threshold value used to distinguish between signal and noise, with a minimum parameter setting of no less than 6. It is recommended to use default parameters. If you have any requirements, please contact SMERI.

Echo Window: setting an area centered around the echo signal, only searching for echo signals within the area, and echo signals outside the area are invalid. It is recommended to use default parameters. If you have any requirements, please contact SMERI.

Rate of Level Change: the maximum allowable level change rate for each detection. It is recommended to use default parameters. If you have any requirements, please contact SMERI.

Fixed Offset: it is recommended to use the default automatic gain mode and not modify it. If you have other requirements, please contact SMERI.

Gain Mode: gain mode is divided into manual adjustment signal gain mode and automatic adjustment signal gain mode.

When gain model = 0, is in automatic gain mode; Gain model = 1 is in manual gain mode

Automatic gain can be automatically adjusted based on the strength of the ADC signal.

It is recommended to use the default automatic gain mode and not modify it. If you have other requirements, please contact SMERI.

Gain One: signal gain control value in the TIA gain chip is between 0-3, and manual adjustment is not required in automatic gain mode.

Gain Two: signal gain control value in the VGA gain chip is between 0-24, and manual adjustment is not required in automatic gain mode

It is recommended to use default parameters. If you have any requirements, please contact SMERI.

False Wave Threshold: used in conjunction with false echo position: The false wave threshold only takes effect when the false echo position is specified. The false wave threshold is a multiplier coefficient used to filter the height of false echoes.

It is recommended to use default parameters. If you have any requirements, please contact SMERI.

Echo Width: default parameters are not recommended for modification. If you have any requirements, please contact SMERI.

Power: when Power is configured to 0, the PGA gain is adjusted first, and the TIA gain is not automatically increased. It is recommended to use the default of 0.

Power One: this parameter is for the search target mode;

When Power 1 is set to 1, it means that the target is the distance corresponding to the maximum amplitude of the echo that exceeds the set threshold, which is the maximum value search. When Power 1 is set to 0, it means that the target is identified as the distance corresponding to the target with the echo exceeding the set threshold and the farthest forward in distance.

It is recommended to use the default parameter 1 and search by the maximum value. If you have any requirements, please contact SMERI.

Backup the parameters: After the working parameters are backed up, if there is an error in manually modifying the parameters and the original working parameters are forgotten, the working parameters can be "restore" in the basic settings.

Restore the parameters: It is used to restore the backup parameters.

7. Radar local operation

Parameter setting user interface

The **devices with display** uses a key mode for parameter setting, and the key functions are shown in Figure.

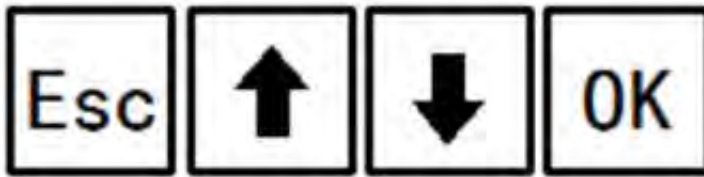

Key	Function
ESC	Back / Enter echo wave interface
UP	Up shift/ Increase key
DN	Down shift / Decrease key
OK	Ok key / Enter setting parameter interface



Main interface description

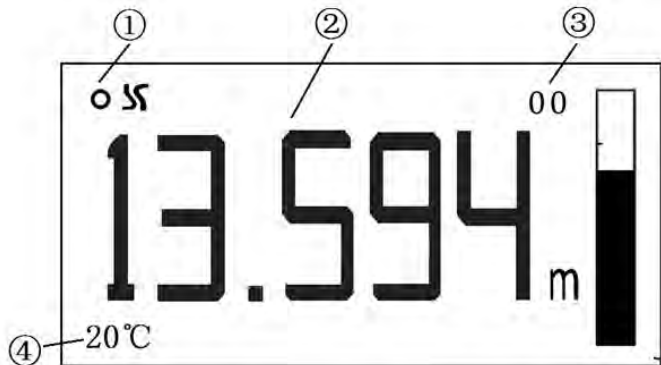

Figure 4. LCDmain interface

①	Work instructions	Flashing reminder when working
②	Level display	Level value (m/mm/cm/fi/ft)
③	Error code	00: No error (Does not show error) 01: No target detected 02: Level value jumped 08: Current output out of range, check setup value
④	Temperature	Display the temperature value when the temperature display function is turned on.

Wave interface description



①	Gap value
②	Echo quality
③	Echo position

7.1 Radar Level Transmitter parameter menu

User parameter menu description

User Para	Basic setup	Range
		Offset
		Pos:4ma
		Pos:20ma
		Blind
		Damping Time
		Device ID
		Baud Rate
	Backup Para	
	Restore Para	

- **Basic setup:**

Range (500~50000mm): depends on working conditions; farthest distance the radar can measure.

Offset (-9999~9999mm): depends on working conditions.

(Pos:4ma): level corresponding to 4mA current output, unit: mm.

(Pos:20ma): level corresponding to 20mA current output, unit: mm.

Blind: 230mm to the measuring range, can be set according to specific working conditions.

Damping time: to improve stability of the measured output value, a larger [Damping time] can be set to stabilize the measured value and increase the anti-interference ability.

For example, if the damping time is 10, the measured level changes step by step at time t, and the measured output value will follow the actual position of the measured object after 10 seconds.

Device ID: address of the slave during 485 communications, is the address of the local machine (value range: 1-99, default value is 1).

Baud rate: The baud rate of this machine during 485 communications is 9600 by default.

- **Backup Parameter:**

After the working parameters are backed up, if you forget the original working parameters after manually modifying the parameters and forget the original working parameters, you can "Restore Parameter" in the menu.

- **Restore Parameter:** Used to restore the backed up user parameters.

Basic Parameters

Range: max. distance to 0%, (container height)

Migration Amount: never put any value

4mA Location: lowest part o the measure 0% (usually 0 meter)

20mA Location: total measuring range 100% (usually range <-> blind)

Blind Area: distance where there is no echo evaluation

EXAMPLE

Silo height 10.000 mm, range 9500 mm

Range: 10.000 mm

Migration Amount: never put any value (0)

4mA Location: 0

20mA Location: 9500 mm

Blind Area: 400 mm

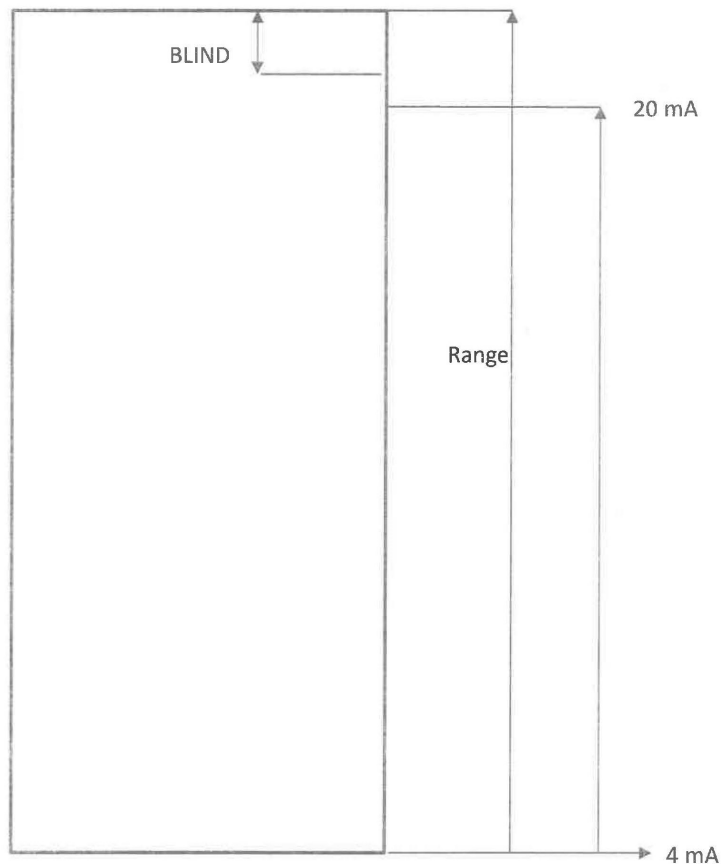

7.2 Software configuration instructions

Press the key to set the parameters

- **Instrument connection**

The power cord is connected to the DC 24V terminal of the instrument, please pay attention to the positive and negative poles, and do not connect them wrongly.

- **Set instrument parameters**

Facing the display window of the instrument, press the "**OK**" button, the meter will display "**Main menu**", as shown in the figure below:

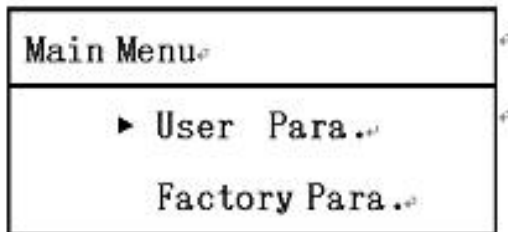

Press the "**OK**" button to enter the "**User Para**".

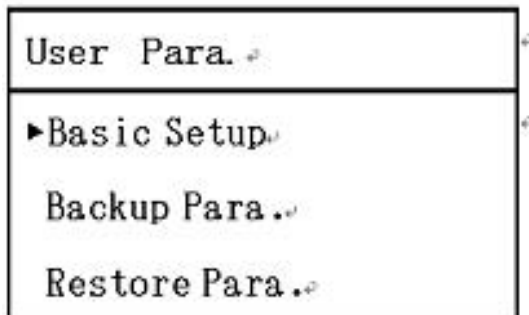

Press "**OK**" button to enter "**Basic Setup**".

Set the "**Range**" according to the working conditions, press "OK", after the range value is reversed, use the "**Upshift**" and "**Downshift**" button to input the range value, and then press the "**OK**" button to confirm.

Press "**Downshift**" button to select "Offset", press "OK" to reverse the migration value, enter the migration value, and press "OK" to confirm.

The same steps can be used to modify "**Pos:4ma**"/"**Pos:20ma**"/"**Blind**"/"**Damping Time**". After the modification, press the "**Backspace**" key to return to the "**User Para**" interface.

When the display type is set to level, the main interface shows the actual level value. When the display type is set to Ullage, the main interface displays the Ullage measured by the radar. Set the display type as required.

Pos:4ma and **Pos:20ma** must be within the range. The relationship between the 4mA position, 20mA position and the range is shown in the figure below:

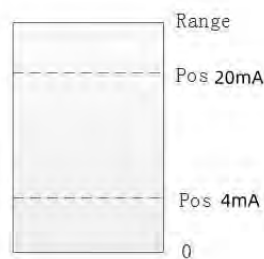

If the level is lower than **Pos:4ma**, the main interface shows that the level is **0**;

if the level is higher than **Pos:20ma**, the main interface shows that the level is **Pos:20ma**.

Backup the parameters: After the working parameters are backed up, if there is an error in manually modifying the parameters and the original working parameters are forgotten, the working parameters can be "restore" in the basic settings.

Restore the parameters: It is used to restore the backup parameters.

8. Radar Modbus communication

Radar S-810-L in ABS, S-810-EL and S-812-L Modbus connection

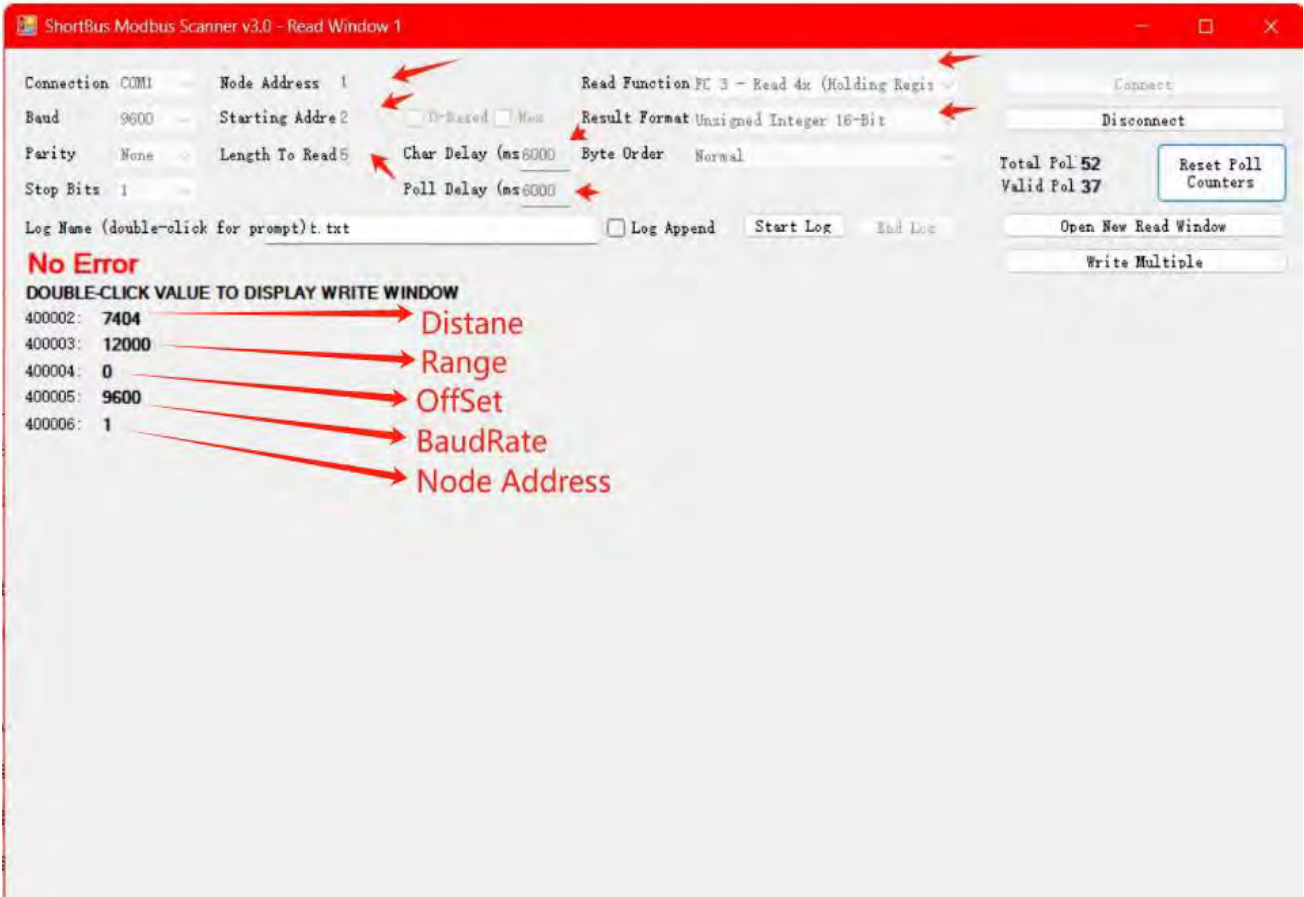

1: Read Paras, Use Command 0x03

Register List:

Address	Description	Data Type	Remark
0002H	Current Level	16 bit unsigned integer	Unit: mm
0003H	Measure Range	16 bit unsigned integer	Unit: mm
0004H	Base Offset	16 bit signed integer	Unit: mm
0005H	Baudrate	16 bit unsigned integer	Unit: bps
0006H	Device ID	16 bit unsigned integer	Value: 1-255

2: Write Paras, Use Command 0x10

Register List:

Address	Description	Data Type	Remark
0003H	Measure Range	16 bit unsigned integer	Unit: mm
0004H	Base Offset	16 bit signed integer	Unit: mm
0005H	Baudrate	16 bit unsigned integer	Unit: bps
0006H	Device ID	16 bit unsigned integer	Value: 1-255

1. Function code 03 (Read input register)

Frame format:

Upper computer sends device address Function code Register start address Number of registers
16-bit CRC checksum

Radar replies: device address Function code Number of bytes Data 16-bit CRC checksum

Note: Support different register start addresses, different number of registers to read.

name	register address	byte count
Level/1000 (m)	0x01	2
Range (mm)	0x02	2
Migration (mm)	0x03	2
baud rate	0x04	2
device address	0x05	2

PC program

device address	0x01 (default)	0th byte
function code	0x03	1st byte
Register Starting Address	Data type: 16-bit unsigned integer	2nd and 3rd bytes
Number of registers	Data type: 16-bit unsigned integer	4th and 5 th bytes
16-bit CRC checksum		6th and 7th bytes

Radar:

device address	0x01 (default)	0th byte
function code	0x03	1st byte
byte count		2nd byte
Level/1000 (m)	Data type: 16-bit unsigned integer, unit: mm	3rd and 4th bytes
range (mm)	Data type: 16-bit unsigned integer, unit: mA	5th and 6th bytes
Migration (mm)	Data type: 16-bit unsigned integer, unit: %	7th and 8th bytes
baud rate	Data type: 16-bit unsigned integer, unit: bit/s	Bytes 9 and 10
device address	Data type: 16-bit unsigned integer	11th and 12th bytes
16-bit CRC checksum		13th and 14th bytes

Example:

Reads level, range, migration, baud rate, and device address:

01 03 00 01 00 05 D4 09

01 03 0A 79 B7 7D 00 00 00 25 80 00 01 E8 DC

Reads only the range:

01 03 00 02 00 02 65 CB

01 03 04 7D 00 00 00 E2 5F

2. Function Code 16 (Modify Register)

Frame format:

Upper computer sends: device address Function code Register start address Number of registers

Number of bytes Data written 16-bit CRC checksum

Radar Response: device address function code register start address number of registers 16-bit CRC checksum

Note: Supports writing to different register start addresses and different numbers of registers.

name	register address	value range
Range(mm)	0x02	[50,32000]
Migration (mm)	0x03	[-10000, 10000]
baud rate	0x04	[1200,57600]
device address	0x05	[1,255]

PC program

device address	0x01 (default)	0th byte
function code	0x10	1st byte
Register Starting Address		2nd and 3rd byte
Number of registers		4th and 5th bytes

byte count		6th byte
Range (mm)	Data type: 16-bit unsigned integer, unit: mA	7th and 8th bytes
Migration (mm)	Data type: 16-bit unsigned integer, unit: %	9th and 10th bytes
baud rate	Data type: 16-bit unsigned integer, unit: bit/s	11th, 12th bytes
device address	Data type: 16-bit unsigned integer	13th and 14th bytes
16-bit CRC checksum		15th, 16th bytes

Radar:

device address	0x01 (default)	0th byte
function code	0x10	1st byte
Register Starting Address	Data type: 16-bit unsigned integer	2nd and 3rd byte
Number of registers	Data type: 16-bit unsigned integer	4th and 5th bytes
16-bit CRC checksum		6th and 7th bytes

Example:

Modify the range, migration volume:

01 10 00 02 00 02 04 13 88 00 64 F7 33

01 10 00 02 00 02 E0 08

Modify the range only:

01 10 00 02 00 01 02 13 88 AA E4

01 10 00 02 00 01 A0 09

3. Function code 0x48 (ADC waveform handshaking)

Frame format:

PC program sends: device address Function code 0x00 0x00 0x13 0x88 16-bit CRC checksum

Radar Reply: device address Function code 0x00 0x00 0x13 0x88 16-bit CRC checksum

PC program

device address	0x01 (default)	Byte 0
function code	0x48	1st byte
	0x00	2 nd Byte
	0x00	3rd byte
	0x13	4th byte
	0x88	5th byte
16-bit CRC checksum		6th and 7th bytes

Radar:

device address	0x01 (default)	0th byte
function code	0x48	1st byte
	0x00	2nd byte
	0x00	Byte 3
	0x13	4th byte
	0x88	5th byte
16-bit CRC checksum		6th and 7th bytes

Example:

01 48 00 00 13 88 EC 92

01 48 00 00 13 88 EC 92

4. Function code 0x47 (ADC waveform)

PC program

device address	0x01 (default)	0th byte
function code	0x47	1st byte
	0x00	2nd byte
	0x00	3rd byte
Number of Waveform Points	2048 points	4th and 5th bytes
16-bit CRC checksum		6th and 7th bytes

Radar:

device address	0x01 (default)	0th byte
function code	0x47	1st byte
Number of Waveform Points	2048 points	2nd and 3rd bytes
waveform		
16-bit CRC checksum		

Example: **01 47 00 00 08 00 B2 05**

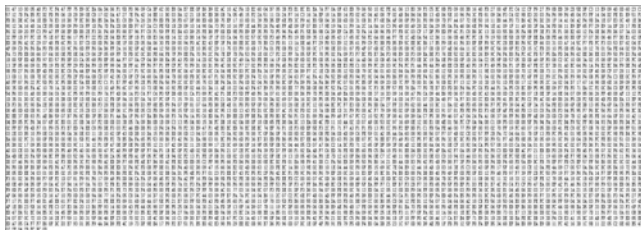

5. Error Code

Read Register Address Error Radar Response:

device address	0x01 (default)	0th byte
function code	0x83	1st byte
	0x02	2nd byte
16-bit CRC checksum		3rd and 4th bytes

Read register count error radar reply:

device address	0x01 (default)	0th byte
function code	0x83	1st byte
	0x03	2nd byte
16-bit CRC checksum		3rd and 4th bytes

Write Register Address Error Radar Response:

device address	0x01 (default)	0th byte
function code	0x90	1st byte
	0x02	2nd byte
16-bit CRC checksum		3rd and 4th bytes

Write register number error radar reply:

device address	0x01 (default)	0th byte
function code	0x90	1st byte
	0x03	2nd byte
16-bit CRC checksum		3rd and 4th bytes

Write byte count error, parameter error radar reply:

device address	0x01 (default)	0th byte
function code	0x90	1st byte
	0x04	2nd byte
16-bit CRC checksum		3rd and 4th bytes

Feature Code Error Radar Response:

device address	0x01 (default)	0th byte
function code	Error Function Code Highest Position I	1st byte
	0x01	2nd byte
16-bit CRC checksum		3rd and 4th bytes

6. CRC calculation checksum formula

CRC16_MODBUS: The polynomial $x^{16} + x^{15} + x^2 + 1$ (0x8005), with initial value 0xFFFF, low before and high after, results in an iso-or with 0x0000.

9. Maintenance

- Pay attention to keep the radar level sensor clean, try to be waterproof, moisture-proof, anti-corrosion and avoid violent collisions and blows from other objects.
- Avoid direct sunlight on the main body of radar level sensor, keep away from heat sources and pay attention to ventilation. If the ambient temperature exceed the rated temperature, corresponding cooling protection measures should be taken.
- When the ambient temperature is too low, an instrument protection box or other protections methods can be used for antifreeze protection, and keep the transmitter dry.
- The radar should be tested regularly (the frequency determined by the user according to the specific situation).

10. Fault handling

Symptoms	Cause of issue	Solution
No display	Power Supply	Check whether the DC 24V voltage and current meet the requirements or
	Wiring	Check the wiring uis correct.
Unstable Value	Strong fluctuating	Change the installation position of the radar or reduce the fluctuation of the product to be measured.
	Weak Echo	Try angle alignment or rotate the radar installation position.
	Strong Electromagnetic interference	Connect to the host to the ground or shield.

Error code:

E01: Level not found

E02: Level jump is too large

E04: Abnormal capacitor charging

E40: Screen communication failure

E08: Actuallevel does not match 4-20mA position (high, low)



SMERI WEB



SMERI PRODOTTI



SMERI SERVICE
MANUALI



SMERI SERVICE
TUTORIAL

SMERI srl

I 20057 Assago (MI) - Via Mario Idiomi, 3/13
Tel +39 02 5398941 - Fax +39 02 5393521
smeri@smeri.com - www.smerri.com

